

92

cm



GLOBAL GARDEN PRODUCTS

Workshop manual

2007

92
92 hydro

WORKSHOP MANUAL

Rel. 8.0

YEAR OF MANUFACTURE **2007**

The Manufacture reserves the right to make any improvements to the product of a technical or commercial nature that may be necessary. There may be, therefore, differences between the various series of machines and that described here, though the basic features and various repair methods will remain the same.

© by GLOBAL GARDEN PRODUCTS - No use of the illustrations or duplication, reproduction or translation, even partial, of the texts in this document may be made without explicit authorization.

CONTENTS

1. Rules and procedures for Service Centres

This chapter covers all the main aspects of the relationship between the manufacturer and the service centres.

A close collaboration between the manufacturer and the service centres is conclusive for solving problems in the most effective way as well as maintaining an image of efficiency and reliability. Compliance with these brief and simple guidelines will facilitate this task and prevent general misunderstandings and time-wasting for both the manufacturer and the service centre.

2. General and safety regulations

This chapter covers the main aspects of a servicing procedure and the general rules for guaranteeing a successful service which protects the environment and respects the safety of both the serviceman and the user of the apparatus.

3. Maintenance

This chapter deals with the criteria for routine maintenance.

4. Adjustments and tuning

This chapter deals with the adjustments to be made to remedy the more frequent performance failures and are usually resolved by quick checks and tunings.

5. Removal of external parts and main assemblies

For doing more difficult jobs, greater accessibility may be required. This can be done by taking the unit concerned off and working at the bench, or by removing the cover or other external parts. Whether or not this will be useful is at the discretion of the mechanic's experience.

6. Repairs

This chapter deals with all the more complex work connected with the replacement or repair of malfunctioning or worn parts.

The descriptions must follow a logical sequence and can include operations not specifically connected to a particular type of repair.

In this case, careful reading of the entire procedure can help you omit all those operations not connected with the case in hand without, however, overlooking anything that may be necessary.

7. Electrical system

This chapter deals with the problems and checks connected with the electrical system.

All work can be done using a tester without having to use special equipment.

The electrical diagrams can be useful to you for understanding how the system functions and to facilitate the pinpointing of any problems.

8. Technical specifications

This chapter summarises all the main information regarding the machine.

GENERAL INDEX

1.1	1	Identification and procedures
2.1	1	Safety regulations
2.2	2	Tools
2.3	1	Lifting
2.4	1	Vertical position
2.5	1	Practical hints
3.1	1	Criteria for maintenance
4.1	0	Blade engagement adjustment
4.2	0	Blades brake adjustment
4.3	1	Brake adjustment

4.4	0	Drive belt adjustment
4.5	1	Drive pedal adjustment (▶ <i>Hydrostatic drive models</i>)
4.6	1	Aligning the cutting deck
4.7	1	Steering allowance adjustment
4.8	0	Steering geometry adjustment
4.9	0	Checking blades alignment
4.10	2	Removing, sharpening and balancing the blades
5.1	1	Removal of front hood
5.2	1	Removal of wheels cover
5.3	0	Removal of the collector channel
5.4	1	Removal of the fuel tank
5.5	1	Removal of the engine
5.6	2	Removal of the rear axle
5.7	2	Removal of the cutting deck
6.1	1	Replacement of tyres and wheels
6.2	0	Replacement of front wheel bearings
6.3	1	Dismantling of the steering components
6.4	1	Replacement of drive belt
6.5	1	Replacing of the small wheels for the drive belt
6.6	1	Replacement of the blades belt
6.7	0	Replacement of the lifting cable
6.8	0	Replacement of the blades engagement cable
6.9	0	Replacement of the supports and shafts of the blades
6.10	0	Replacement of the accelerator
6.11	1	Replacement of the brake pads and disc (▶ <i>Mechanical drive models</i>)
7.1	2	Guide to the identification of problems in the electrical system
7.2	1	Summary table for the cutting in of the safety devices
7.3	2	Safety microswitches operation check and switches
7.4	2	Terminal board supply check
7.5	–	---
7.6	2	Starter relay operation check
7.7	2	Electronics card operation check
7.8	2	Recharge circuit check
7.9	1	Care and maintenance of the sealed battery
7.10	1	Fitting safety microswitches
7.11	3	Electrical diagrams
8.1	2	Tightening torques and adjustments summary
8.2	1	Summary of main assembly amounts and checks

<p>ii.1 INTRODUCTION</p>	<p>from 1997 to page 1 / 1</p>
------------------------------	------------------------------------

INTRODUCTION

This manual has been compiled to help Service Centres with the maintenance, dismantling and repair of the following versions of the J92 lawn-tractor:

- mechanical drive with gear box;
- hydrostatic drive (hydro).

Each page of this manual states the following information:

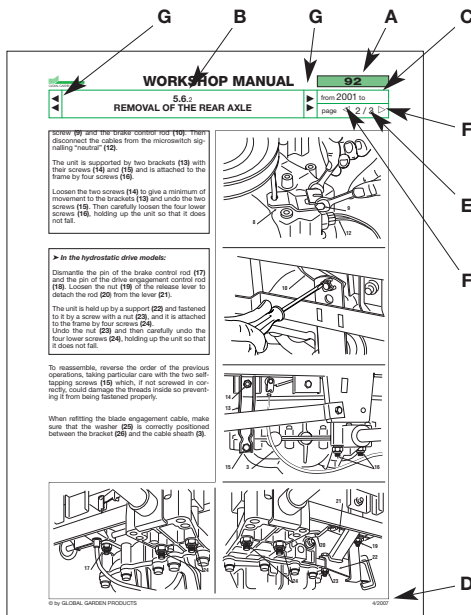

- A)** Machine or machine series to which the page applies.
- B)** Page number, specifically:
 - the first two figures separated by a point indicate the section and the chapter
 - the third figure indicates the modification index.
- C)** Temporary validity of the page, with reference to the year of manufacture or serial numbers.
- D)** Date of release.
- E)** Page number and total number of pages dedicated to the subject.
- F)** Any previous or ensuing pages dedicated to the subject.
- G)** Any chapters before or after the current one.

The manual refers to the following symbols:

⚠ Warns of operations that should be carried out with utmost care to avoid impairing the functionality and safety of the lawnmower.

⚠ Warns of operations that should be carried out with utmost care to avoid injury to the operator.

👉 Reference to another procedure or part of the manual.

➤ This symbol highlights all those operations that require different working methods depending on the type of machine, subsequent modifications or accessories fitted.

NOTE
Whenever a reference is made to a position on the machine “front”, “back”, “left” or “right” hand side, this is determined by facing the direction of forward travel.

The manual has left out the simplest and quickest operations that can be handled by a good mechanic, while concentrating more on specific aspects and the best servicing procedures.

You are asked to read through this manual to acquire a basic understanding of the machine, which is necessary for working rationally without making errors or wasting time.

All problems related to use are fully covered in the user manual.

1.1 IDENTIFICATION AND PROCEDURES

A) Identification

1) Machine

Each machine has a label attached (1) under the driver's seat which shows the technical specifications, the model and the serial number.

The model and serial number must be shown on each repair sheet when requests are made under guarantee, and are indispensable for spare part orders.

2) Transmission (Rear axle)

The transmission unit (both mechanical and hydrostatic) is made up of an engine block including the rear axle. This unit is made by another manufacturer to our precise technical specifications which differentiate it from similar items by this same Manufacturer.

The serial number on the label (2) clearly identifies the product and its specifications. This number must always be quoted when requesting spare parts or any information from the Manufacturer.

3) Engine

The engine is made to precise technical specifications which differentiate it from similar items by this same Manufacturer.

The serial number on the label clearly identifies the product and its specifications. This number must always be quoted when requesting spare parts or any information from the Manufacturer.

B) Guarantee validity

The guarantee is supplied under the terms and the limits of the contractual relations in being. As far as the engine and the transmission unit are concerned, the conditions given by their respective manufacturers apply.

C) Service repairs after guarantee period

The Service Centre has to make out a report containing the machine's serial number, a summary of

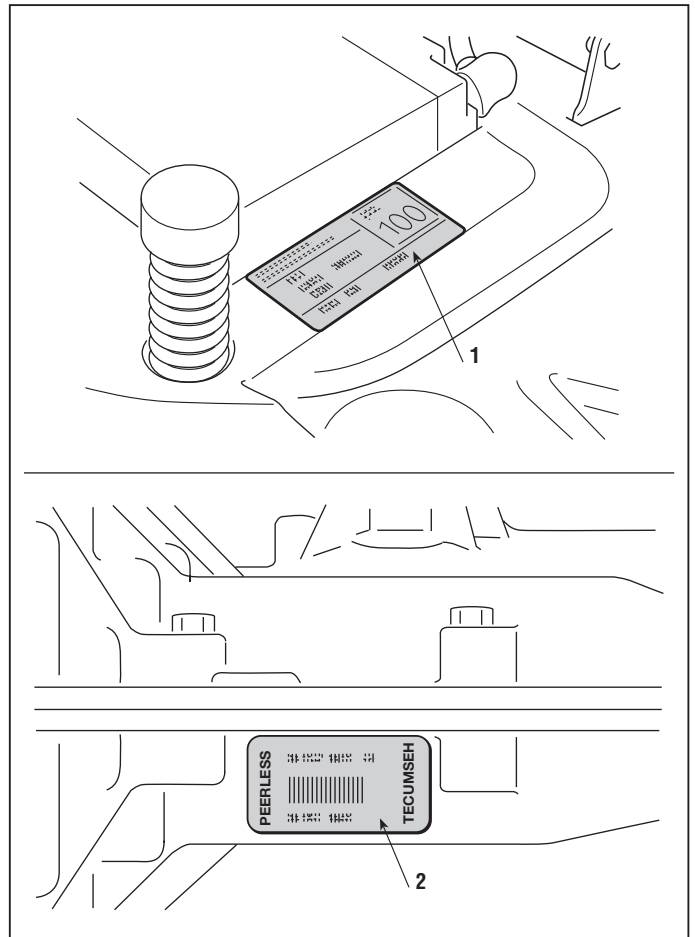

the problem, the repairs carried out and any spare parts used for each repair done on the machine.

A copy of this report must be retained to be made available to the Manufacturer together with the parts in case of any subsequent disputes with Customers.

D) Fault notification

The Manufacturer welcomes any notifications of faults that recur with particular frequency. It gives the opportunity for a careful inspection of the problem and the implementation of corrective action at production level.

Similarly, the Manufacturer will notify of any faults discovered on the machines produced, with recommendations for the most suitable procedures for their remedy.

E) Spare parts request

When requesting spare parts, the code number must be given, referring to the exploded charts for the year of manufacture, shown on the identification label [point A].

2.1.1 SAFETY REGULATIONS

from 1997 to

page 1 / 1

2.1 SAFETY REGULATIONS

A) Qualification of operators

All maintenance, disassembly and repairs must be carried out by expert mechanics who are familiar with all the accident prevention and safety regulations after reading through the procedures in this manual.

B) Safety measures

All the machines are manufactured in accordance with the strict European safety regulations in force. To maintain these levels of safety in the longer term, the Service Centres should work to this end by making appropriate checks every time there is the chance to do so.

Particularly, every time there is work done on the machine the Service Centre should:

1) check:

- that safety microswitches are working correctly [see 7.3];
- that the casings and protection covers have not been removed;
- that the labels with instructions or provisions have not been removed or have become illegible (these form an integral part of the safety system).

2) they should also:

- restore to proper working order any safety devices which have been manipulated or removed;
- reattach inefficient, damaged or missing casings and protection covers;
- replace illegible labels;
- not endorse any repair or modification on the machine or the engine which results in a change in performance or use that is incorrect or different from the purpose for which it was designed and approved;
- warn the Customer that the failure to comply with the above points results in the automatic annulment of the Guarantee and the Manufacturer declines all responsibility, as also shown in chapter 1 of the Instruction Booklet.

C) Precautions during servicing

The operations described in this manual do not entail particularly hazardous situations besides the

normal hazard related to mechanical operations and that can be avoided by taking the necessary care and attention normally required for this type of work.

As well as following the usual accident prevention regulations that apply to most repair shops, we recommend you:

- taking out the ignition key before beginning any repair work.
- protect hands with suitable working gloves, especially when working near the cutting unit;
- check that you do not cause accidental petrol leaks or other losses;
- do not smoke when working on the tank or when handling petrol;
- do not inhale oil or petrol fumes;
- clean up all traces of spilt petrol immediately;
- test the engine in a well-ventilated environment or where there are adequate exhaust fume extraction systems;
- do not pollute the environment with oil, petrol or other waste and dispose of all waste in accordance with the laws in force;
- ensure that other persons cannot accidentally carry out actions that may physically endanger those working on the machine.

D) Necessary equipment

All the operations can be carried out with the tools normally used in a good garage.

Some operations require special equipment and tools [see 2.2].

E) Symbols and terms used for safety purposes

Some paragraphs in this manual are preceded by symbols which indicate the following:



Operations that should be carried out with utmost care to avoid impairing the functionality and safety of the lawnmower.



Operations that should be carried out with utmost care to avoid injury to operators.

“WARNING” stresses the risk of injury to oneself and others if instructions and regulations are not observed



2.2.2 TOOLS

from 1997 to

page 1 / 1

2.2 TOOLS

All work can be carried out using the tools normally available in a good workshop. However, it is advisable to have a kit of special tools **(1 ÷ 5)**.

These tools **(1 ÷ 5)** are to be used whenever is given in this text.

1. Blocks H = 26 mm for adjusting the cutting deck
2. Blocks H = 32 mm for adjusting the cutting deck
3. Bush for assembly of blades bearings
4. Stopper for assembly of wheel bearings
5. Pulley extractor

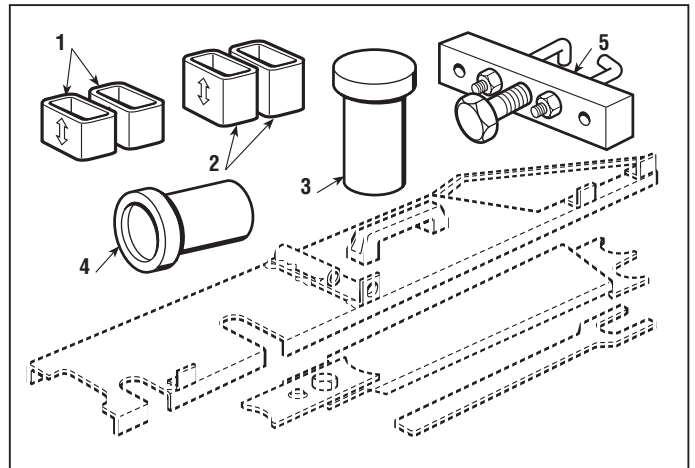



2.3.1 LIFTING

from 1997 to

page 1 / 1

2.3 LIFTING



The machine must never be lifted using a hoist or other lifting equipment which uses cables.



A) Front

ONCE THE PARKING BRAKE HAS BEEN ENGAGED, the lawn-tractor can be lifted using a jack which pushes on the underside of the frame, placing a wood block **(1)** between the base of the jack and the frame and checking to see that the free movement of the front spring equaliser has not been obstructed.

B) Rear

Place a suitable block **(2)** beneath the lower edge of the plate. In any case, an appropriately sized wedge **(3)** should be placed behind the opposite wheels to stop the lawn-tractor from accidentally moving backwards.

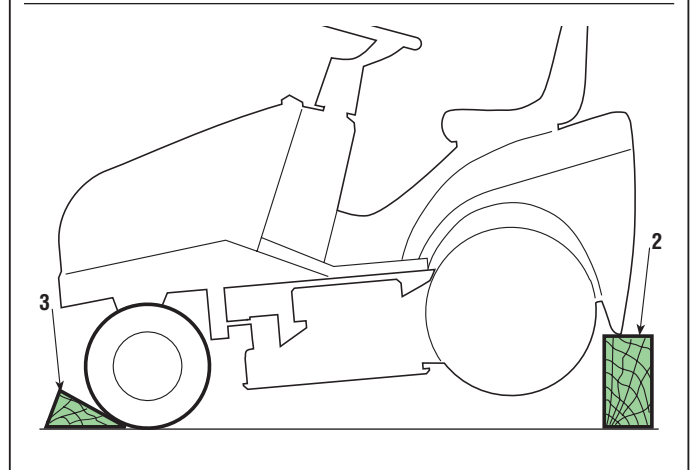
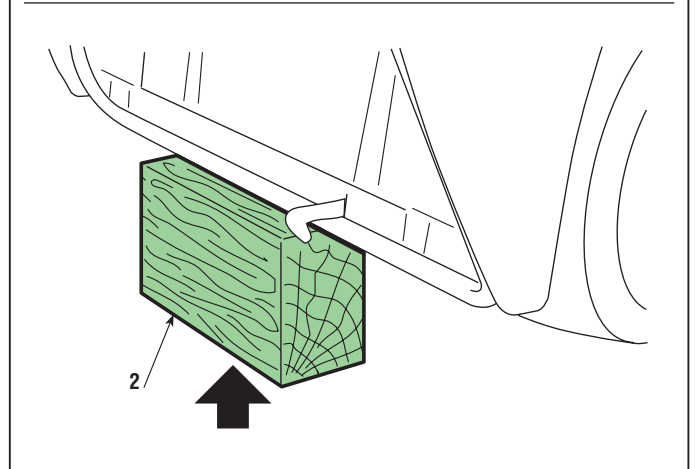
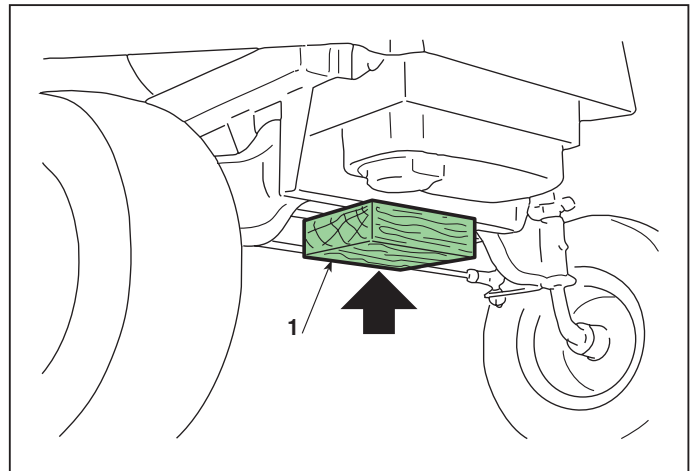

2.4.1 VERTICAL POSITIONING

from 1997 to

page 1 / 1

2.4 VERTICAL POSITIONING



WARNING! Two people will be needed for this operation. When lifting and tipping backwards, only solid parts should be gripped (steering wheel, frame, rear plate, etc.) and **NEVER** parts of the bodywork in plastic.

The tank must be checked before putting the lawn-tractor in a vertical position to make sure that there is no more than 2 litres of fuel inside.

To assure full stability, the lawn-tractor must only be rested on the points shown, inserting a block **(1)** of about 120 mm under the lower edge of the plate and taking care not to damage the parts in plastic and the grass-catcher mounts **(2)**.



WARNING! Before carrying out any type of work make sure that the machine is completely stable, and avoid operations that could cause it to fall over.



WARNING! Be just as careful when putting the machine back on a flat surface; two people are needed for this operation.

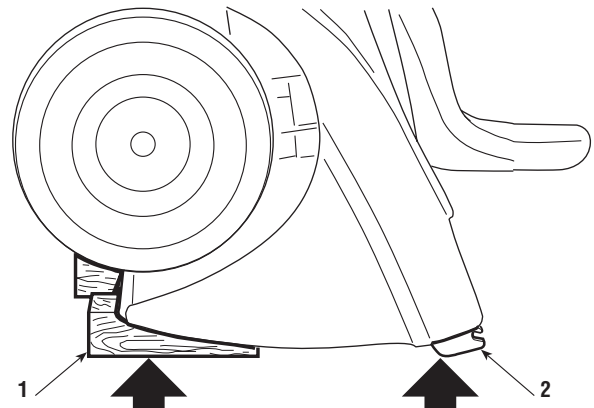
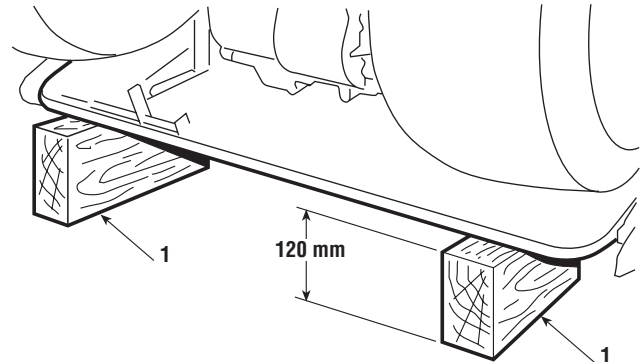



2.5.1 PRACTICAL HINTS

from 1997 to
page 1 / 1

2.5 PRACTICAL HINTS

A) Fitting snap rings

One side of the “Benzing” snap rings (1) has a rounded edge and the other a sharp edge.

For maximum grip the rounded part needs to be facing towards the element to be held (2), with the sharp edges on the outside.

B) Joint pivot pins

There are a large number of pivot pins, usually connected to rods, that need to be able to move in various directions.

A typical situation has the pin (3) fixed by a self-locking nut (4) with two anti-friction washers (5) in between the pin (3) and the support element, and between this and the nut (4).

Since these are joints, the nut must never be tightened completely but only so much that it can ensure the free rotational movement of the pin on its axis without, however, creating excessive free play which could result in the parts concerned becoming misaligned and failing to work correctly.

C) Crown fasteners

Some pin ends (6) are secured by crown fasteners (7). During dismantling, these fasteners are always damaged and lose their hold, **so they should never be reused.**

On assembly, make sure it is inserted in the right direction and push the fastener (7) onto the pin using a pipe or socket spanner (8) with the right diameter, so that it can be fitted without deforming the fastener “crown”.

A deformed fastener should always be replaced.

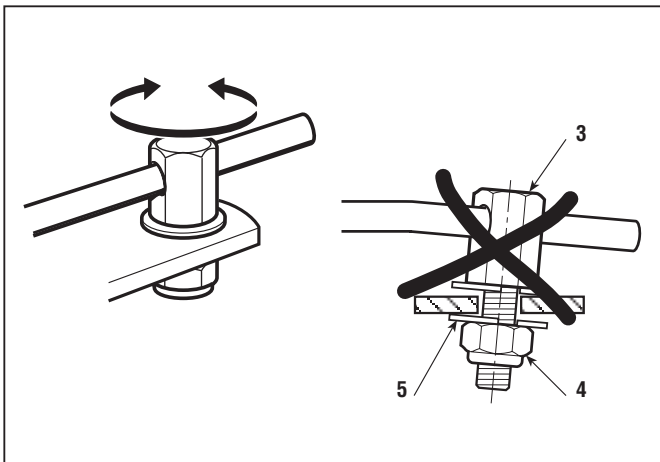
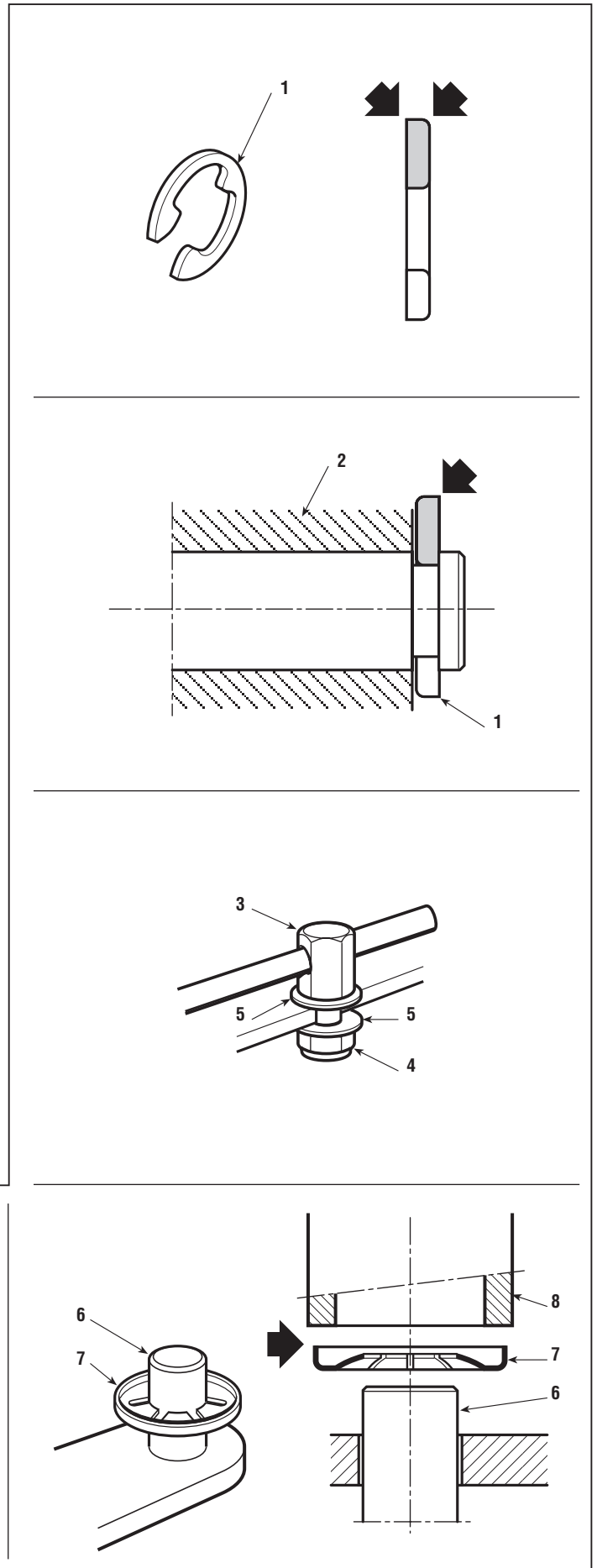

3.1.1 CRITERIA FOR MAINTENANCE

from 1997 to

page 1 / 1

3.1 CRITERIA FOR MAINTENANCE

The Instruction Handbook has a number of operations to be carried out by the Customer for a minimum of basic maintenance, and other operations not always within his capacity.

For this reason the Service Centre should undertake to keep the machine in perfect working order in two ways:

- a) Tuning the machine whenever possible.
- b) Proposing a regular maintenance programme to the Customer to be carried out at prearranged intervals (for example, at the end of the summer or prior to a long period of inactivity).

a) Occasional tuning

- Check working order of safety devices and renew illegible or missing labels
- Check tyre pressures
- Clean air filter
- Check engine oil level
- Check for fuel leaks
- Align cutting deck
- Sharpen and balance the blades and check the condition of the hubs
- Check for wear in the belts
- Check the blade brake engagement
- Grease front wheels lever joint pins and bushes
- Grease the bush of the drive pedal (► *hydrostatic drive models*)
- Check tightness of engine screws
- Check all those items indicated in the engine manual

b) Regular maintenance

- **All work carried out in section a), plus:**
- Check battery charge
- Check tension of belts
- Adjust drive engagement (► *mechanical drive models*)
- Adjust brake
- Adjust blade engagement
- Adjust blades brake
- Check steering allowance
- Check front bearings
- Check cutting deck lifting cables
- General lubrication
- Clean away grass cuttings and wash exterior
- Clean and wash inside cutting deck and collector channel
- Clean and wash grass-catcher
- Touching up of any damaged paint

4.1.0 BLADE ENGAGEMENT ADJUSTMENT

from 1997 to

page 1 / 1

4.1 BLADE ENGAGEMENT ADJUSTMENT

The blades are run from the engine using a “V” belt and are engaged by a stretcher worked from the lever.

After a certain amount of use the belt and the cable can become longer which can result in malfunctioning, i.e.:

- belt slipping = belt or cable stretched
- difficulty in disengaging, with a stiff lever and the blades continuing to run = belt shortened

In both cases the stretcher needs to be adjusted.

With the cutting deck in its lowest position, look for the adjuster **(1)** which can be reached from the wheel arch of the right-hand rear wheel. Turn the nuts until the spring **(2)** reaches the length 97 ÷ 99 mm, measured from the outer edge of the eyelet with the blades engaged.

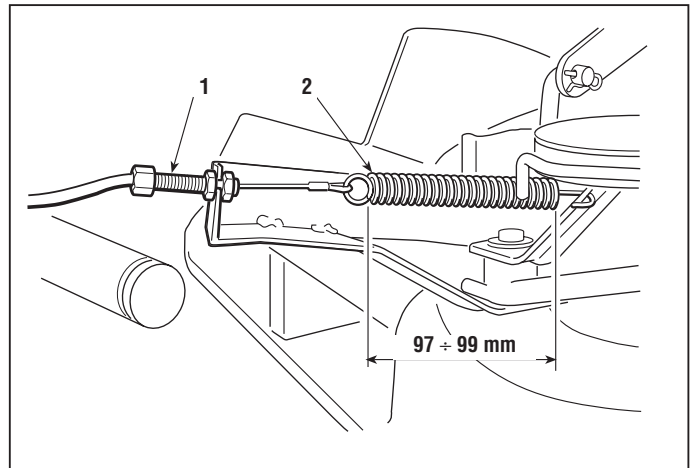

4.2.0 BLADES BRAKE ADJUSTMENT

from 1997 to

page 1 / 1

4.2 BLADES BRAKE ADJUSTMENT

Disengaging the blades causes a double brake to come into action. This is to stop the blades turning within five seconds. Longer braking times do not comply with safety regulations, but adjusting the brake so that it stops quicker than this can cause the belt to slip on the shoes resulting in overheating with the typical smell of burnt rubber.

Take off the right-hand protective guard (1) by unscrewing the nut (2) and loosening the two screws (3). Take off the left-hand guard (4) held by two screws (5).

Check that the two shoes (6) are not distorted and that the link rod (7) is not distorted so varying the centre distance.

Check the centre distance of the tie-rod (8) if it has been dismantled or is damaged [see 8.2.10].

Once these checks have been made, disengage the blades and check that both the shoes are in contact with the belt and are applying the same pressure, otherwise tighten or loosen the fork (9) for the tie-rod (8) as much as necessary.

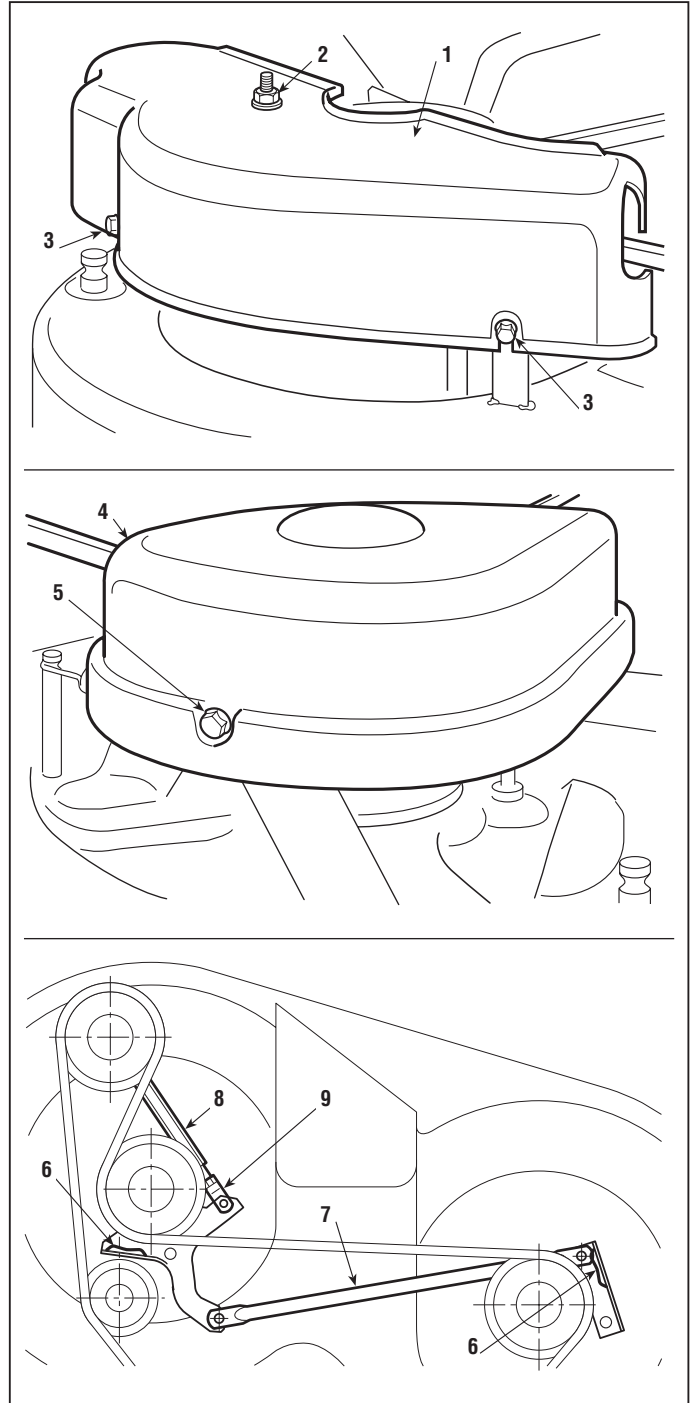

4.3.1 BRAKE ADJUSTMENT

from 2000 to

page 1 / 2

4.3 BRAKE ADJUSTMENT

Reduced braking power is corrected by adjusting the spring on the brake rod.

► **In mechanical drive models:**
 ➤ Remove the fuel tank [see 5.4].

► **In the hydrostatic drive models:**
 Use a socket spanner to make the adjustment through the hole (1) on the rear plate.

The adjustment is to be made with the parking brake engaged and consists of altering the length of the spring (2) to the best measurement. The braking capacity is increased by screwing the nut down on the rod (and thus shortening the length of the spring).

Loosen the nut (4) which retains the bracket (5) and then turn the nut (6) so that the length «A» of the spring (2) is:

- 43,5 ÷ 45,5 mm ► **In mechanical drive models**

- 45 ÷ 47 mm ► **In hydrostatic drive models**

measured from the inside of the washers. When the adjustment has been made, tighten the nut (4).

Never go under these amounts to avoid overloading the brake unit.



When the adjustments have been made, the parking brake should prevent the lawn-tractor from moving on a slope of 30% (16°) with the driver in position.

► **In mechanical drive models:**



If braking is still poor or uneven even after having made the adjustment, remove the control rod (3) from the lever (7) and check that this lever has a free movement of 20 mm (measured vertically next to the pin rod) before beginning the braking action. If this is not the case, the free movement can be adjusted with the screw (8), unless the

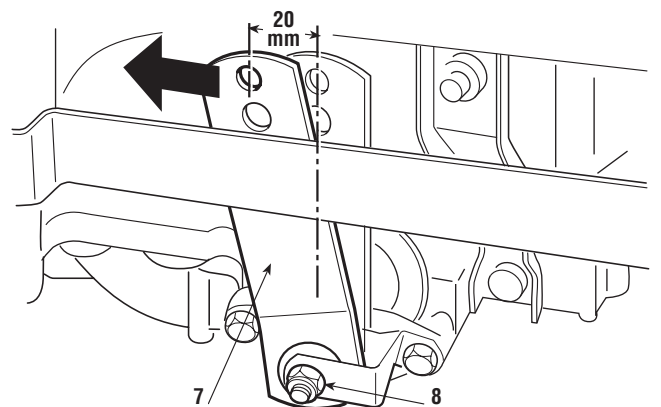
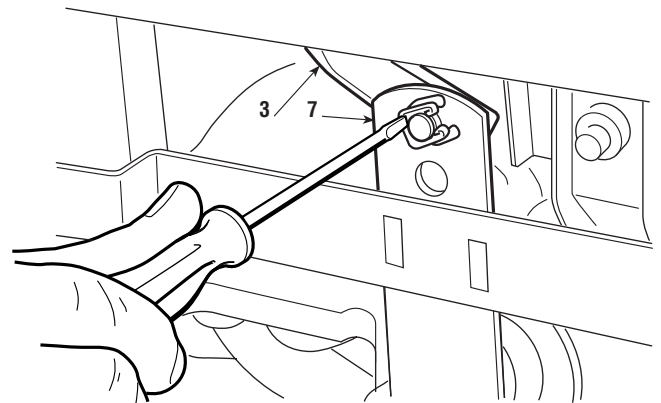
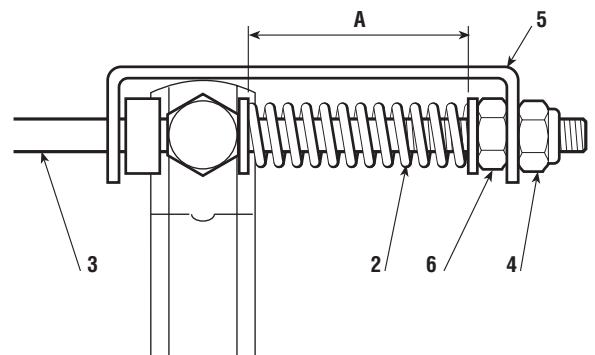
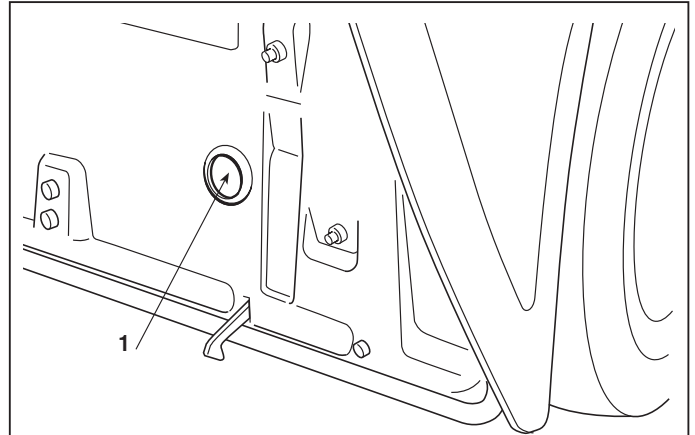

 	4.3.1 BRAKE ADJUSTMENT	 	from 2000 to page ◀ 2 / 2
--	---	--	------------------------------

brake pads or discs are so worn that they need replacing [see 6.11].

When connecting the rod **(3)** be sure to use the uppermost hole in the lever **(7)** and then check the length of the spring again **(2)**.

► ***In the hydrostatic drive models:***

If braking is still poor or unsteady even after making the adjustment, you cannot make any further adjustments from the outside. Therefore you need to dismantle the whole rear axle of the machine [see 5.5] and contact one of the manufacturer's Service Centres.

When assembly is completed ...

► ***In mechanical drive models:***

➡ Refit the fuel tank [see 5.4].

4.4.0 DRIVE BELT ADJUSTMENT

from 1997 to

page 1 / 1

4.4 DRIVE BELT ADJUSTMENT

If it seems that the forward drive is not working properly after a long period of use or after replacing the belt, this may be caused by a change in the length of the belt.

- A loose belt reduces output from the transmission and limits forward movement power;
- a belt which is too tight increases noise and results in jerky movements or tipping up when engaging the drive.

In these cases the stretcher will need to be adjusted.

The stretcher can be accessed from the front hood. Adjust the tension of the spring **(1)** by turning the nuts **(2)** until achieving length «A» of:

– 119 ÷ 121 mm ► *In mechanical drive models*

– 120 ÷ 122 mm ► *In hydrostatic drive models*

measured from the outer ends of the springs with the drive commands disengaged.

When the adjustment has been made, tighten the nuts **(2)**.

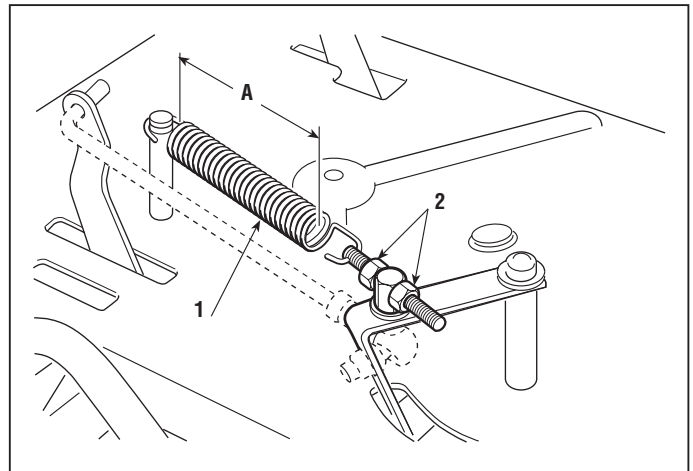

4.5.1 DRIVE PEDAL ADJUSTMENT

from 2001 to

page 1 / 1

4.5 DRIVE PEDAL ADJUSTMENT (► Hydrostatic drive models)

This operation should be carried out every time the rear axle, the pedal or the control rod is removed in order to get the correct travel for the pedal and to enable reaching the envisaged speeds both forwards and in reverse.

A) Adjusting the pedal in the “neutral” position

The pedal (1) is in the ideal position when the lever (2) of the hydrostatic unit is in “neutral” and the lower rubber edge (3) on the reverse side is 24 – 26 mm from the footboard.

The pedal position must be adjusted with reference to the neutral position «N» of the hydrostatic unit lever (2); this position is reached when this lever is perfectly vertical with a tolerance of ± 1 mm ($\pm 0.8^\circ$).

Per eseguire la regolazione ...

➡ Remove the collector channel [see 5.3].

Make the adjustment through the outlet of the rear plate using the nuts (4) of the control rod (5) until the pedal is positioned properly. Take care not to accidentally change the position of the lever (2) during the adjustment.

B) Adjusting the “neutral” position of the micro-switch



IMPORTANT!

This is a very important adjustment for the operation of the safety devices regarding permitting starting and stopping of the lawn-tractor during work.

The neutral position «N» is signalled by the microswitch (6) of the cam (7).

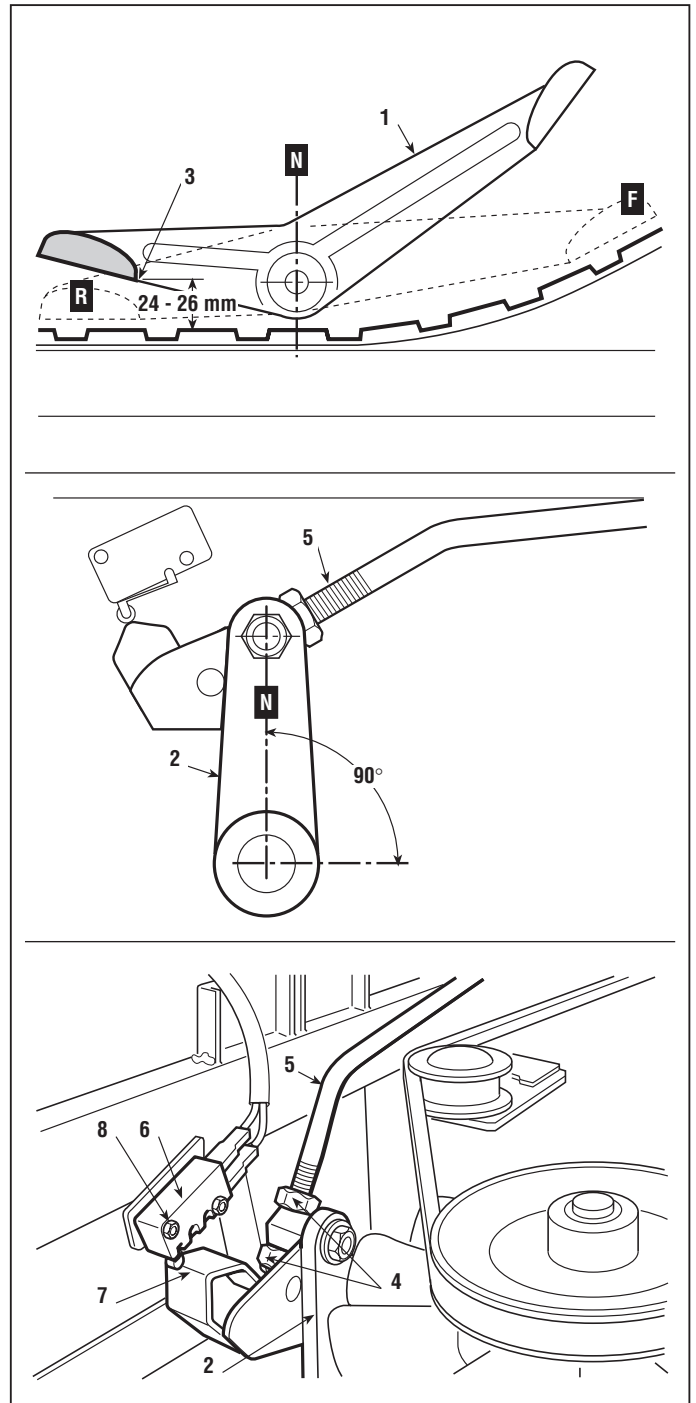

After checking that the adjustment “A” has been correctly made, make sure that the pedal is released and in neutral «N» then loosen the locknuts (8) of the microswitch and position it in line with the tip of the cam.

After making the adjustments, move the pedal (1) from the neutral position «N» to the forward and reverse gear positions: you should hear the click of the button at each gear change before the wheels start moving.

4.6.1 ALIGNING THE CUTTING DECK

from 2003 to

page 1 / 2

4.6 ALIGNING THE CUTTING DECK

The cutting deck is lowered by a level controlled cable, and is moved by two trace rods at the front and back.

In order to get a good cut it is essential that the cutting deck is parallel with the ground crosswise, and slightly lower at the front.

Three adjustments can be made on the jointed system of the cutting deck:

- a combined adjustment to the parallel and the minimum height front and back
- an adjustment to just the parallel across the cutting deck
- adjusting the regularity of raising and lowering

Check the tyre pressures. If one or more tyres have been replaced and there are found to be differences in diameter, **do not attempt to compensate these differences by giving different tyre pressures**, but make the adjustments as in points "A" and "B".

A) The combined adjustment to the parallel and the minimum height front and back

Put the lawn-tractor onto a flat and stable surface (such as a work bench) and put blocks beneath the cutting deck in line with the centre lines of the blades:

- at the front 26 mm (1)
- at the rear 32 mm (2)

Put the height lever in position «1» and completely loosen the adjuster (3), the nuts (4 - 6 - 8) and the locknuts (5 - 7 - 9) of the three trace rods until the deck is resting on the blocks.

Tighten the two rear nuts (4 - 8) and the front right nut (6) to the point where the deck just begins to lift.

Tighten the three locknuts (5 - 7 - 9) and turn the adjuster (3) until the control cable is taut.

Check that the deck rises and lowers regularly as indicated in point "C".

B) Adjusting the parallel across the cutting deck

Any difference in height from the ground between the left and right sides of the deck can be compensated by turning the two nuts (4 - 8) and locknuts (5 - 9) of just the back rods.

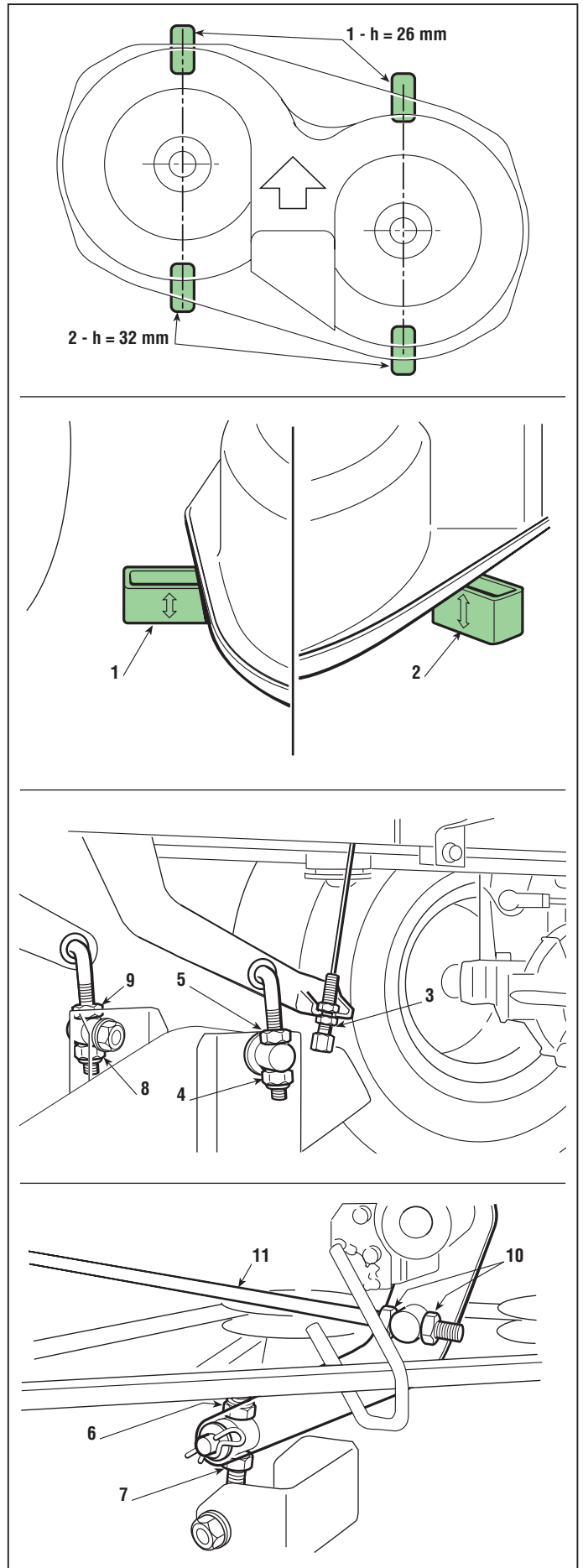

 	4.6.1 ALIGNING THE CUTTING DECK	 	from 2003 to page ◀ 2 / 2
--	--	--	------------------------------

C) Adjusting the regularity of rising and lowering

When the adjustment as at point “A” has been made, put the control lever in 2 or 3 different positions and check that the deck rises evenly and that at each position it constantly maintains the difference in height from the ground between the front and back edges.

If the front part tends to rise faster or slower it can be adjusted by turning the nuts **(10)** on the link rod **(11)**.

Turning the nuts clockwise will lift the front part and make it rise faster, and turning anti-clockwise will give the opposite effect.

The right distance between the two centres is $356 \div 357.5$ mm, which will give an even rise and descent [see 8.2.9].

Remember to tighten all the nuts and locknuts once these adjustments have been made.

4.7.1 STEERING ALLOWANCE ADJUSTMENT

from 1997 to

page 1 / 2

4.7 STEERING ALLOWANCE ADJUSTMENT

The steering allowance should never be excessive if driving is not to be impaired.

Check that the movement is not caused by loose linkage nuts and tighten all the nuts of the tie-rods and ball joints.

If the movement is due to the ring gear / pinion coupling, it will be necessary to adjust the arrangement of the set of blocks between the ring gear and the frame.

➤ Remove the fuel tank [see 5.4].

To facilitate access to the parts concerned, it is best to loosen the drive belt. This is done by ...

➤ **In mechanical drive models:** engaging the parking brake

➤ **In hydrostatic drive models:** loosening the nut (1) of the stretcher.

Release the spring (2) and lift the steering column (3) enough to be able to draw out the pinion (4). Unscrew the nut (5) and take out the whole ring gear shaft (6) without dismantling the tie-rod (7). Take away one or both of the blocks (8) under the ring gear depending on the amount of free play to be reduced.



Reassemble the pinion and the ring gear shaft, lining up the two reference points (→ - ◀) punched on them, and making sure that the notch (9) on the frame slots into one of the housings in the bush. Put the whole assembly back together and fully tighten the nut (5). If the movement is still there after having removed all the spacers, check and, if necessary, replace the ring gear/pinion unit [see 6.3], or look for other possible causes.

➤ **In hydrostatic drive models:** tighten the spring of the stretcher [see 4.4]. If only the front nut (1) has been loosened without having touched the rear one, the right tension will be achieved by just tightening up the nut (1).

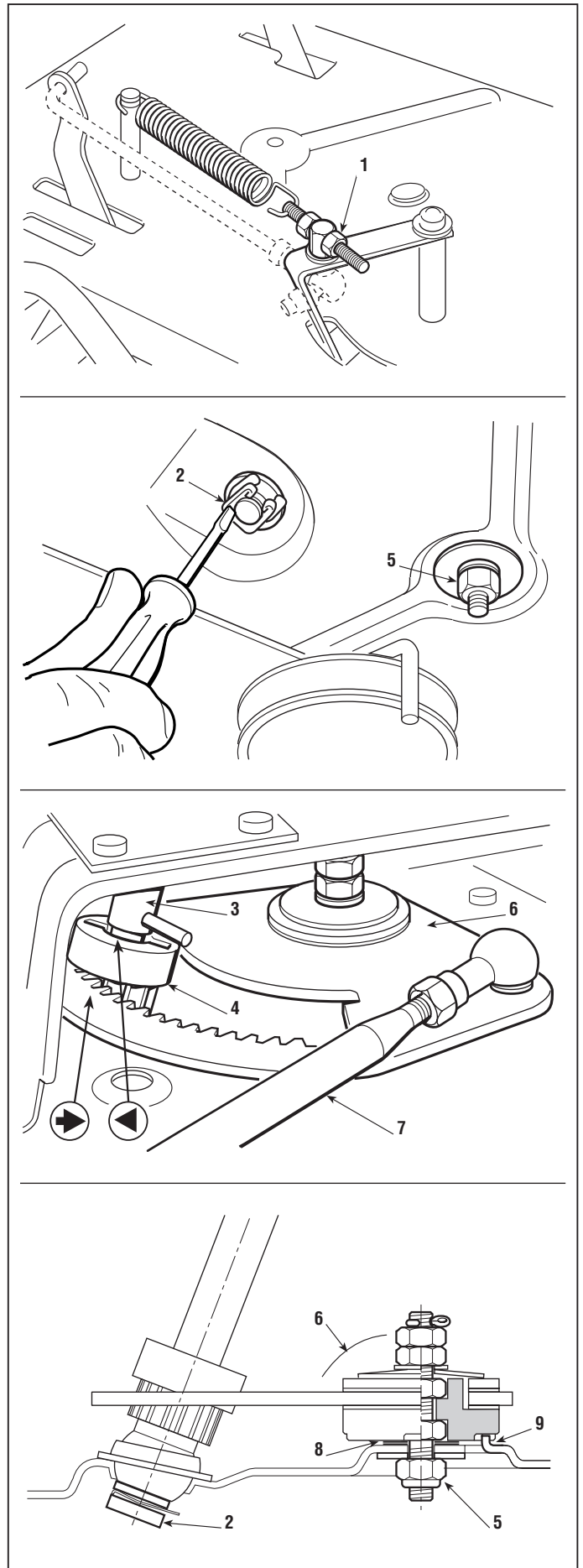

 	<p>4.7.1</p> <p>STEERING ALLOWANCE ADJUSTMENT</p>	 	<p>from 1997 to</p> <hr/> <p>page ◀ 2 / 2</p>
--	---	--	---

When assembly is completed ...

- ➔ Refit the fuel tank [see 5.4].

Tightening torque

5	Nut for ring gear	45 ÷ 50 Nm
----------	-------------------------	------------

4.8.0 STEERING GEOMETRY ADJUSTMENT

from 1997 to

page 1 / 1

4.8 STEERING GEOMETRY ADJUSTMENT

The correct steering geometry is given by the values of the intercentre distance between the joints of the tension rod and the wheel connecting rod. Any faults caused by knocks or accidents result in reduced driving precision and increased wear on the tyres. These can be overcome as follows:

- uneven or excessive wear on the front tyres = toe-in adjustment
- the lawn-tractor does not maintain a straight line when the steering wheel is straight = adjustment of tie-rods.

NOTE

Before any other action, check that the joint fastenings have not become loose.

A) Toe-in adjustment

An exact toe-in is achieved with an centre distance of 461 mm which is measured between the centres of the articulated joints (1) of the wheel connection rod (2). If a different distance is found, dismantle one or both the joints and screw the necessary amount down or up on the rod. On assembly, fully tighten the locknuts (3) and the fastening nuts (4) of the joints.

B) Adjustment of the steering wheel

Firstly check the toe-in (point "A") and align the front wheels. If the steering wheel is not straight, dismantle the articulated joint (5) and screw down or up on the tie-rod (6) for the necessary amount.

On assembly, fully tighten the locknuts (7) and the fastening nuts (8) and check that the tie-rod, in its travel, **does not interfere with parts or accessories of the engine** even with the equaliser (9) angled in both directions.

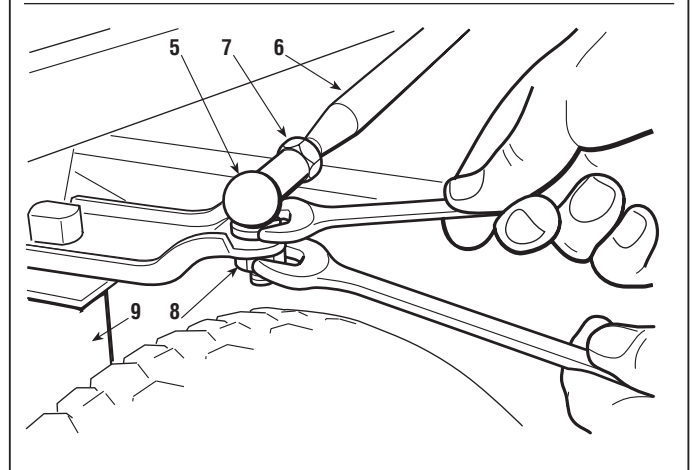
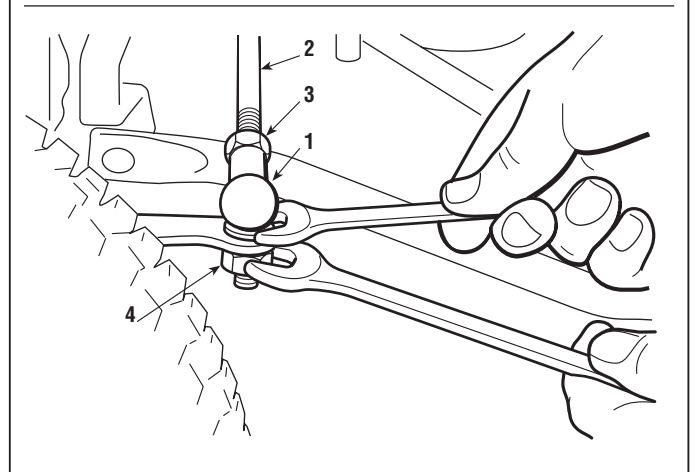
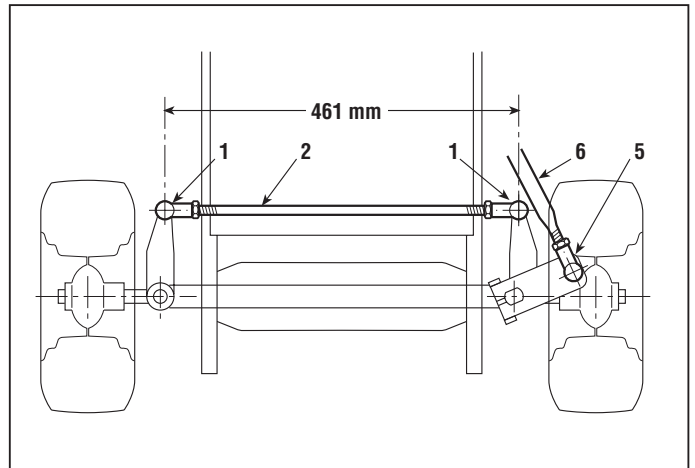

Tightening torques

- 3 - 7 Locknuts for articulated joints 25 ÷ 30 Nm
- 4 - 8 Nuts for articulated joints 45 ÷ 50 Nm

4.9.0 CHECKING BLADES ALIGNMENT

from 1997 to

page 1 / 1

4.9 CHECKING BLADES ALIGNMENT

Excessive vibration when cutting and an uneven cut can be due to misalignment of the blades owing to deformation of the flanges or the shafts as a result of accidental knocks.

- ➡ Put the lawn-tractor into a vertical position [see 2.4].



Always wear strong gloves when handling the blades.

With the blades disengaged, firmly hold each blade and bring the cutting edges together in the various positions possible (A-B; A-B1; A1-B1; A1-B). At each position they should be aligned to within 2 mm.

If higher amounts are found, check that the blades are not distorted. If this is not the case, check the supports or the shafts for the blades [see 6.9], replacing if necessary, and check the condition of the point where the flange rests on the cutting deck.



IMPORTANT!

Always replace damaged blades and do not attempt to repair or straighten them. Always use manufacturer's genuine spare parts!

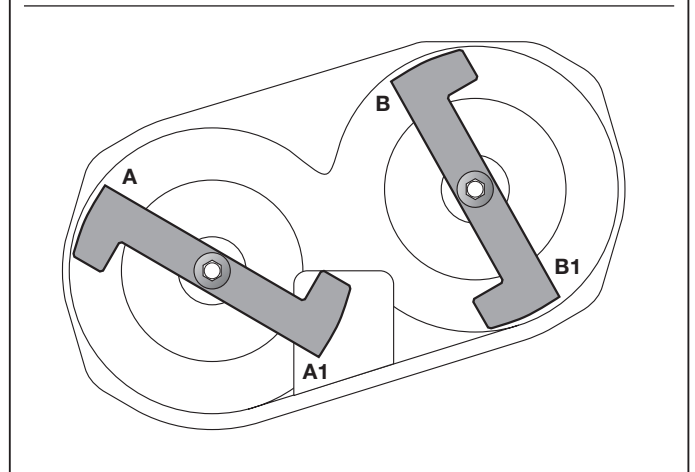
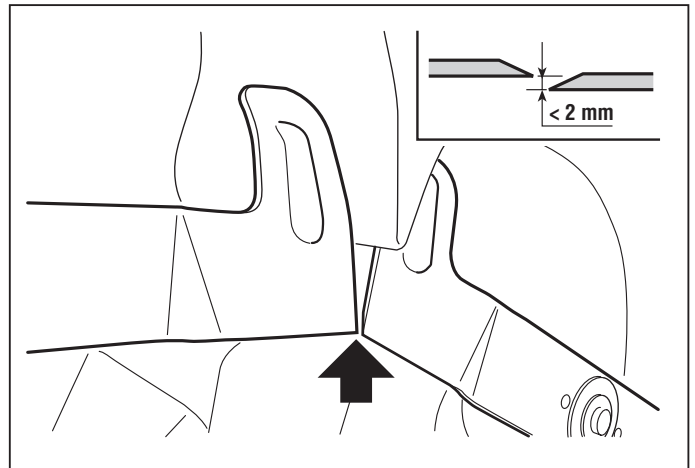

4.10 REMOVING, SHARPENING AND BALANCING THE BLADES

A badly sharpened blade causes grass to become yellow and reduces grass collection capability. If not balanced, excessive vibration can be caused during use.

⚠ Always wear protective gloves when handling the blades and protect eyes when sharpening.

A) Removing and reassembling

For removing a blade it must be firmly held and the central screw (1) undone, bearing in mind that:

- the screw on the left blade (1a) is unscrewed anti-clockwise
- the screw on the right blade (1b) is unscrewed clockwise.

⚠ On assembly, be careful to:

- correctly position the keys (3) on the shafts;
- correctly locate the right and left blades, with the fins facing towards the inside of the plate;
- fit the flexible disc (4) so that the concave part is pressing against the knife;
- tighten the screws (1 - 1a) with a torque wrench set to 45-50 Nm.

B) Sharpening and balancing

Always sharpen both cutting edges of the blade (2) using a medium grade grinder. Sharpening must only be done from the rounded side, removing as little as possible.

The blade is to be replaced when the cutting edge has worn down to 10 mm.

Using the appropriate equipment, check the balance to make sure that there is a maximum difference of 2 grams between one side and the other.

Tightening torques

1a	Screw for left blade	45 ÷ 50 Nm
1b	Screw for right blade	45 ÷ 50 Nm

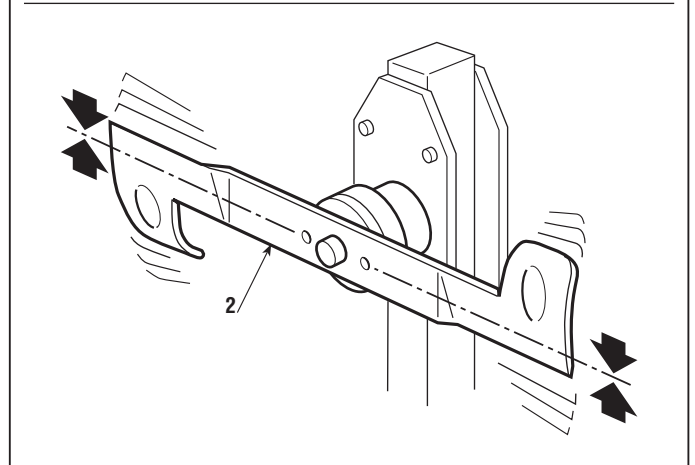
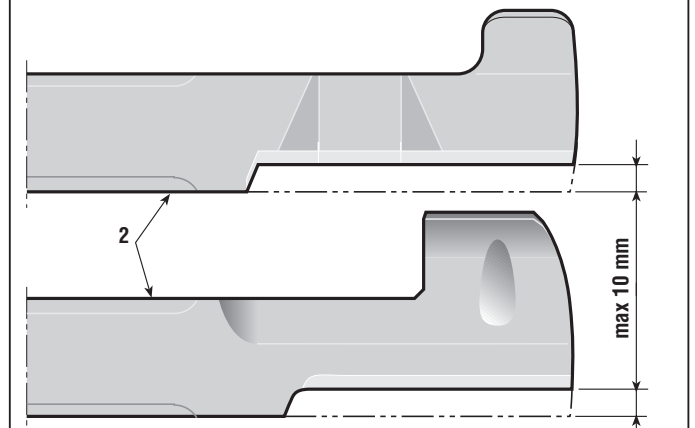
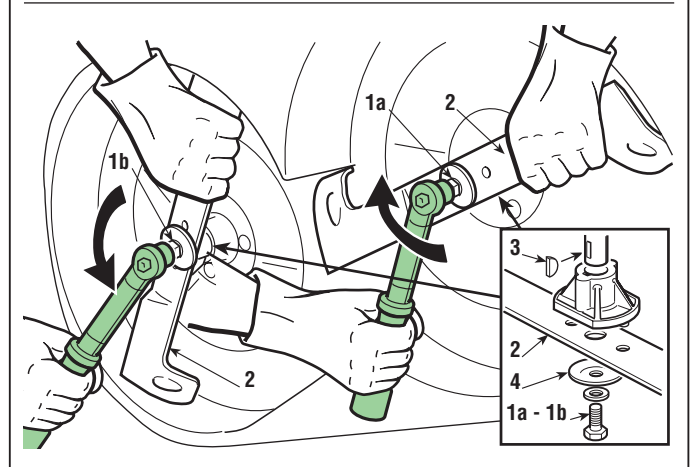
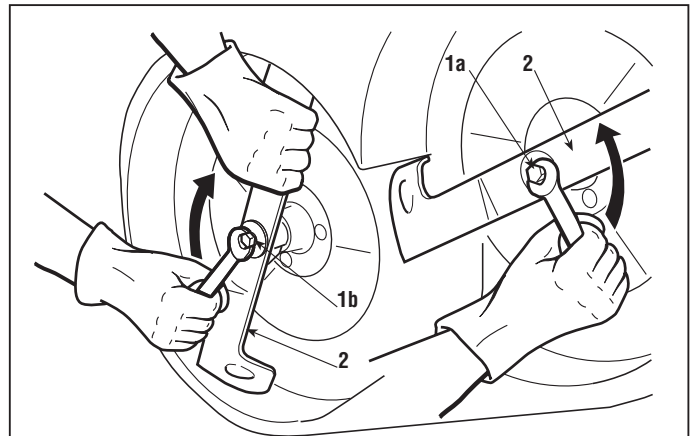

5.1.1 REMOVAL OF FRONT HOOD

from 2001 to

page 1 / 1

5.1 REMOVAL OF FRONT HOOD

The removal of the front hood gives greater accessibility to:

- the engine and its accessories
- the silencer and protection devices

► **In models with lights:**

Disconnect the connector (1).

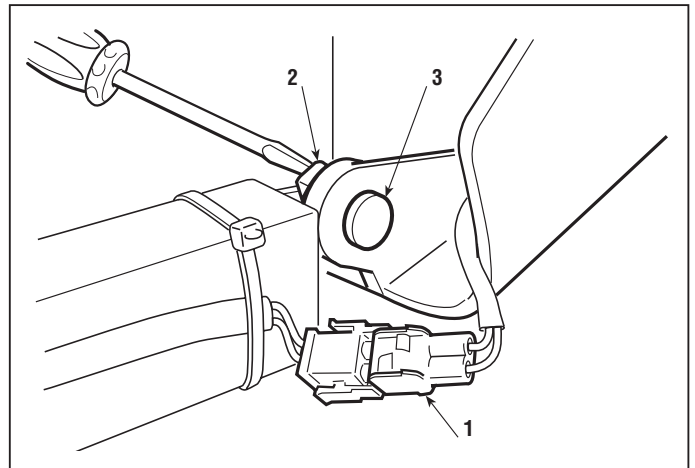

The hood can be secured in two ways.

A) Fixing with springs

Unhook the two fastener springs (2) and pull out the pins (3).

B) Fixing with a split pin

Take out the split pin (4) from the right-hand side and remove the hood by moving it to the right.

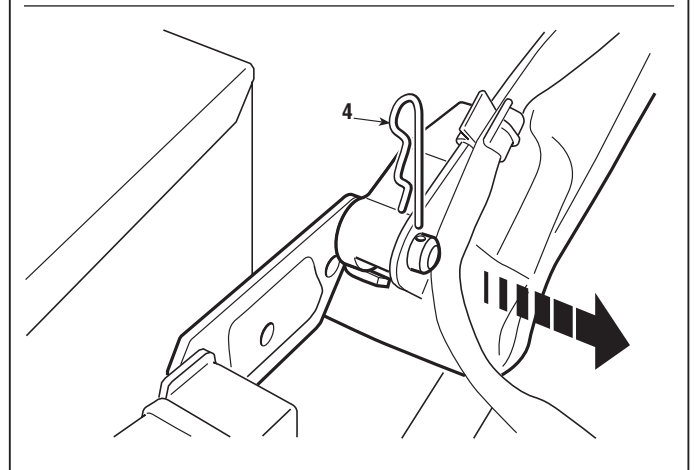

5.2.1 REMOVAL OF THE WHEEL COVER

from 2003 to

page 1 / 2

5.2 REMOVAL OF THE WHEEL COVER

Removing the wheel covers gives access to:

- the mount for the lever to raise the deck;
- the supports of the footboards.

Take off the spring (1) which holds the battery, taking care to prevent it accidentally short-circuiting. Disconnect and remove the battery (2).

► **In mechanical drive models:** unscrew the knob from the blade engagement lever (3) and the knob from the gear lever (4).

► **In hydrostatic drive models:** unscrew the knob from the blade engagement lever (3) and the drive pedal (5).

Remove the caps (6) from the springs and undo the screws inside (7).

Remove the seat after having taken out the two pins (9).

The cover (10) is held by a screw at the front (11), four screws (12) at the bottom of the dashboard

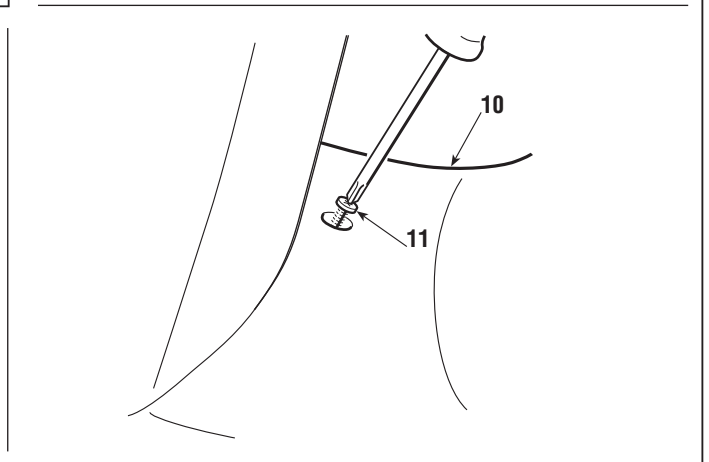
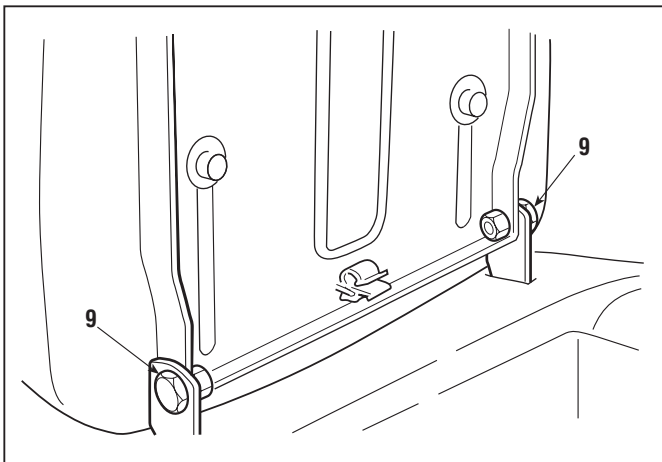
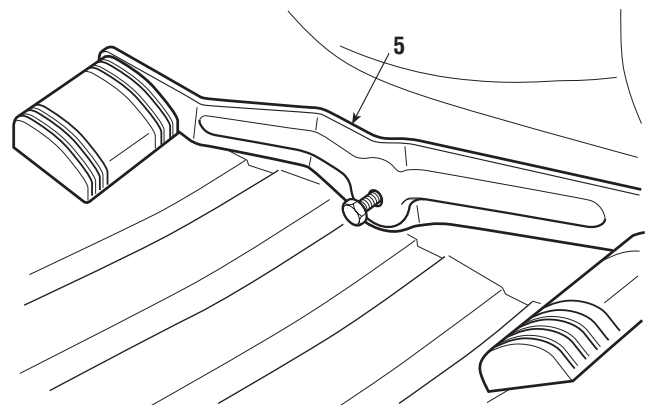
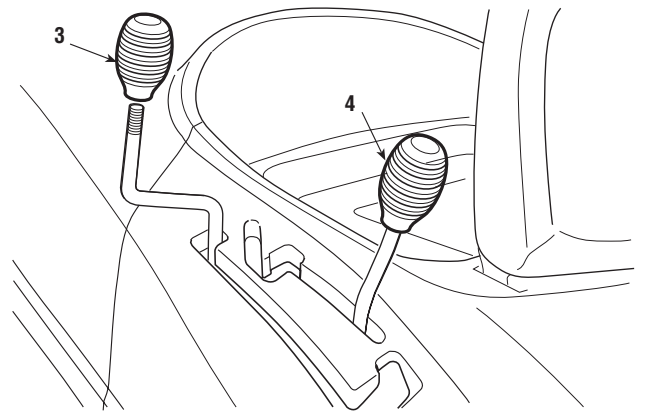
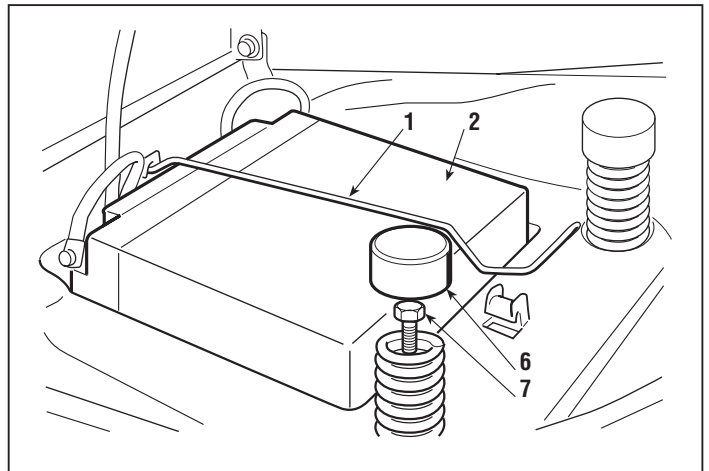

5.2.1 REMOVAL OF THE WHEEL COVER

from 2003 to

page 2 / 2

support and six screws **(13)** under the side foot-board. The two back ones **(13a)** of these last screws have a washer.

When the cutting height lever has been moved to position «7» and the engage lever to the «blades engaged» position, it is possible to remove the cover.

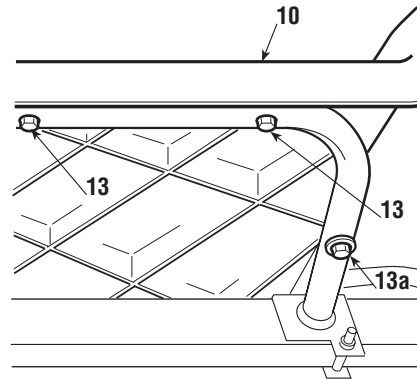
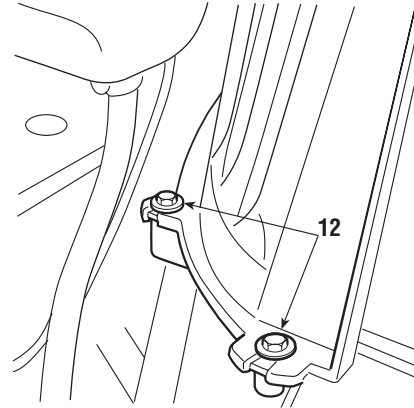



5.3.0 REMOVAL OF THE COLLECTOR CHANNEL

from 1997 to
page 1 / 1

5.3 REMOVAL OF THE COLLECTOR CHANNEL

Removing the collector channel gives access to:

- the deck lifting cable;
- the small side wheels of the drive belt;
- the control rod for engaging drive and the micro-switch to signal «neutral» (▶ in hydrostatic drive models).

Undo the two screws **(1)** the hold the support for the 'sack full' signal microswitch, undo the inside screws **(2)** fixing onto the rear plate and take out the channel **(3)**.

When reassembling, fully tighten the screws **(2)** and make sure that the collector channel moves freely.

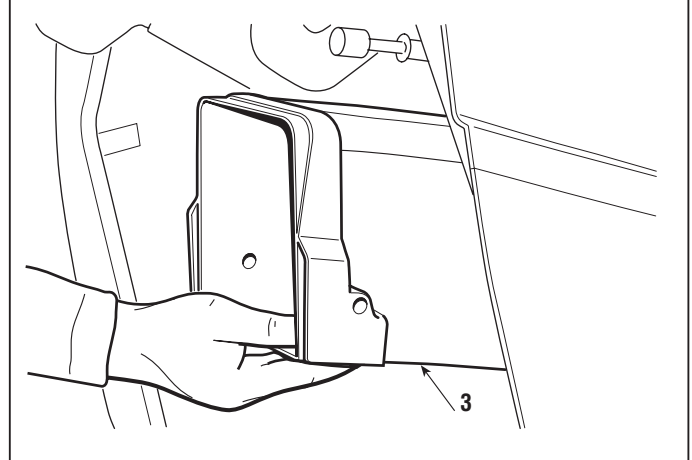
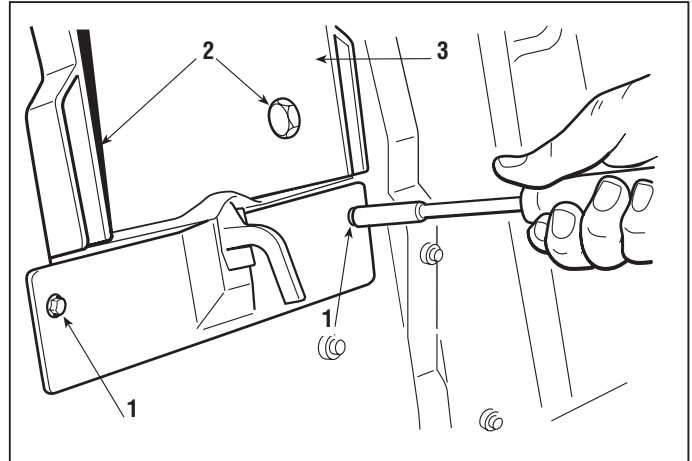

Tightening torque

2 Screws for collector channel 25 ÷ 30 Nm

5.4.1 REMOVAL OF THE FUEL TANK

from 1998 to

page 1 / 1

5.4 REMOVAL OF THE FUEL TANK

Removing the fuel tank gives access to:

- the steering wheel column and the ring gear;
- the brake adjustment spring (► **in mechanical drive models**);
- the accelerator fastening screws.



Completely empty the tank through the pipe at the entry to the fuel filter **(1)**, **taking care not to spill fuel.**

Remove the electronic card, take off the lower part of the protective cover **(2)**.

Loosen the screw **(3)** holding the support **(4)** and lift the tank until the two pegs **(5)** come out of the lower support.



On reassembling, remember to fit the clamp back on the fuel pipe and **check that it does not leak.**

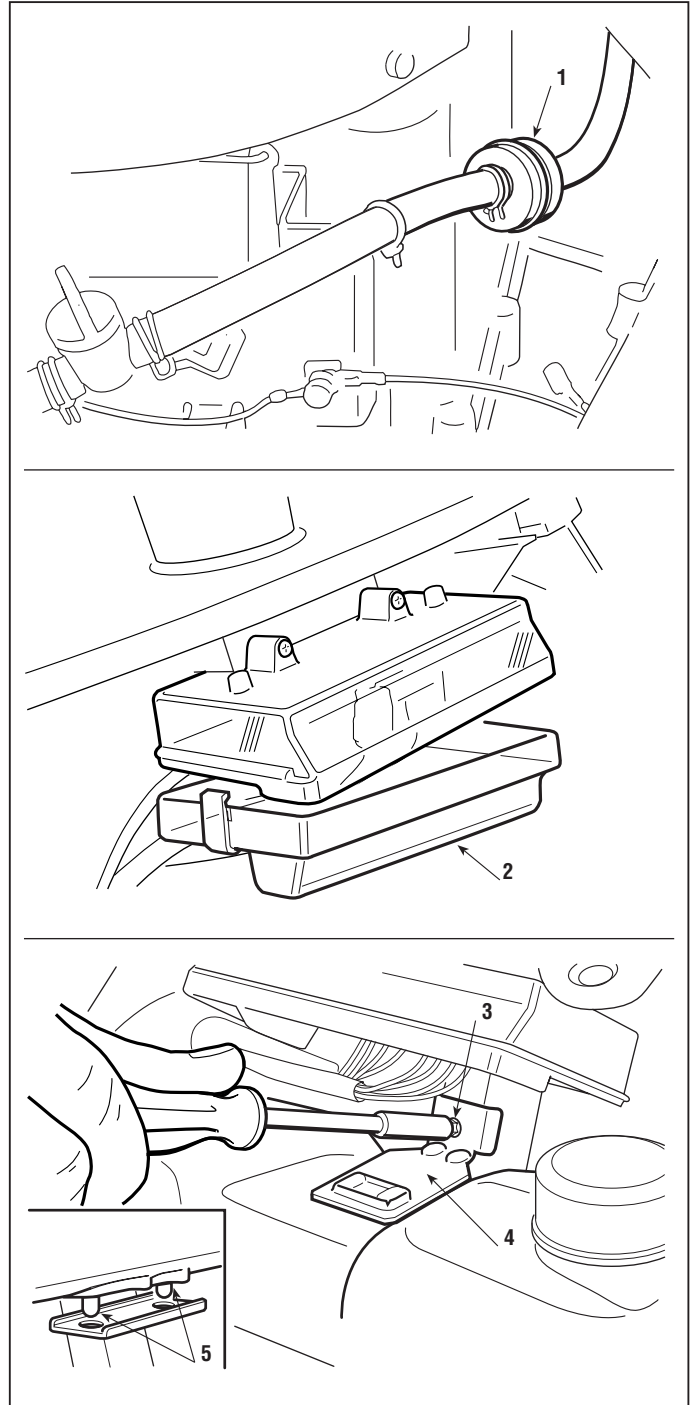

5.5.1 REMOVAL OF THE ENGINE

from 2003 to

page 1 / 2

5.5 REMOVAL OF THE ENGINE

Since there are different types of drive, the stages described here refer to those shared or similar in all types of engine.

➔ Remove the front hood [see 5.1].

Disengage the blades to loosen the belt. In order to have better access to the parts concerned, also the drive belt should be loosened.

This is done by ...

➤ **In mechanical drive models:** engaging the parking brake

➤ **In hydrostatic drive models:** loosening the nut (1) of the stretcher.

Loosen the screw (2), unfasten the safety pin (3) and move the fork to the side (4).

Turn the belt shifter (5) forward until the belt (6) is released from the pulley (7).

Undo the central screw (8) and take out the pulley (7) from the shaft.

If it is difficult to take out, use the special extractor inserted into the holes (9) of the pulley, but do not completely undo the screw (8) so that the extractor puts pressure on the head of the screw and does not damage the threaded hole of the shaft.

Remove the protection from the exhaust (10) and disconnect the cable wires from the accelerator and all the electrical wires.



Detach the fuel line pipe, **taking care not to spill fuel.**

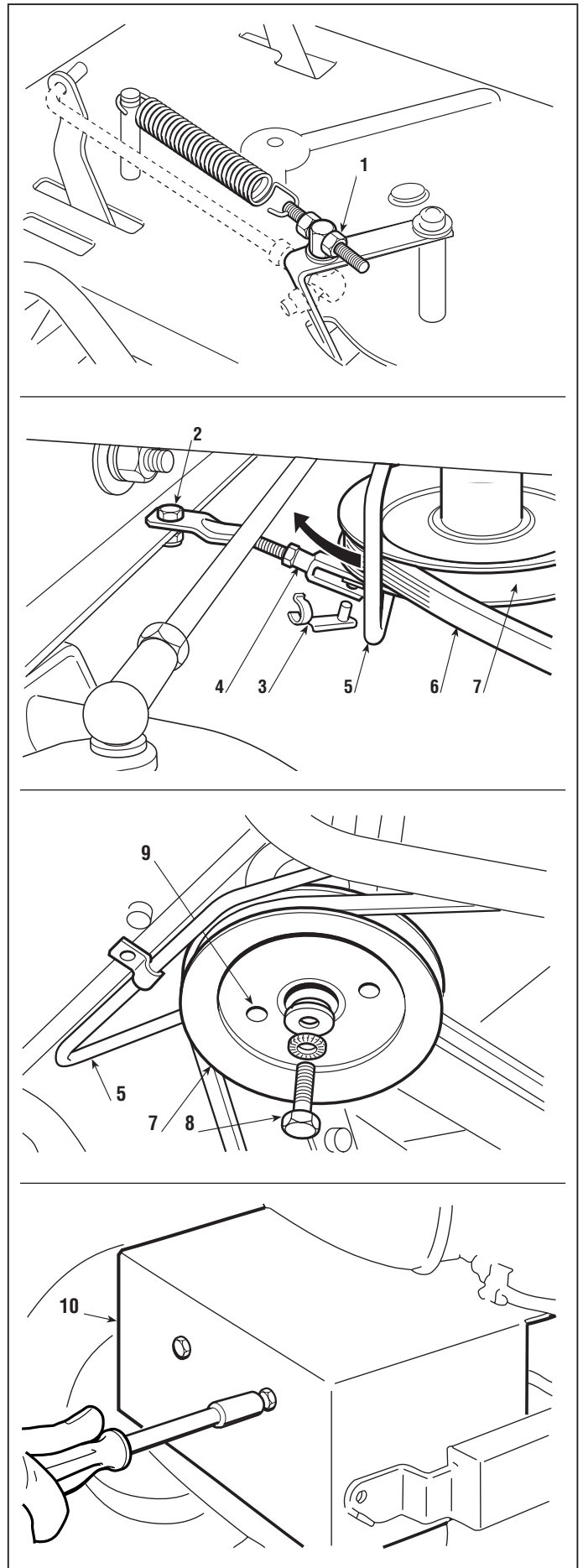



5.5.1 REMOVAL OF THE ENGINE



from 2003 to
page ◀ 2 / 2

Find and undo all the screws holding the engine to the frame, grip the engine firmly and lift it, taking the necessary care bearing in mind that its weight is around 35 kg.

NOTE

Some type of engine are held with screws of different length and in different positions, so it is best to label them so that no errors are made on reassembly. On reassembly, fully tighten the screws for the engine and the pulley to the amounts shown.



Remember to fit the clamp back on the fuel pipe and **check that it does not leak**. Reattach all the electrical and earth contacts and refit the protection covers (if fitted).

To reassemble, reverse the order of the previous operations.

Reset the belt shifter **(5)** into position, refit the fork **(4)** with the relative safety pin **(3)** and fully tighten the screw **(2)**.

► **In hydrostatic drive models:** reset the tension of the stretcher spring [see 4.4]. If only the front nut **(1)** has been loosened without having touched the rear one, the right tension will be achieved by just tightening up the nut **(1)**.

Reattach the accelerator cable and ...

- ➡ Adjust the «MINIMUM» position [see 6.10].
- ➡ Refit the front hood [see 5.1].

Tightening torques

8 Screw for pulley	45 ÷ 50 Nm
- Screws for engine fastening	25 ÷ 30 Nm

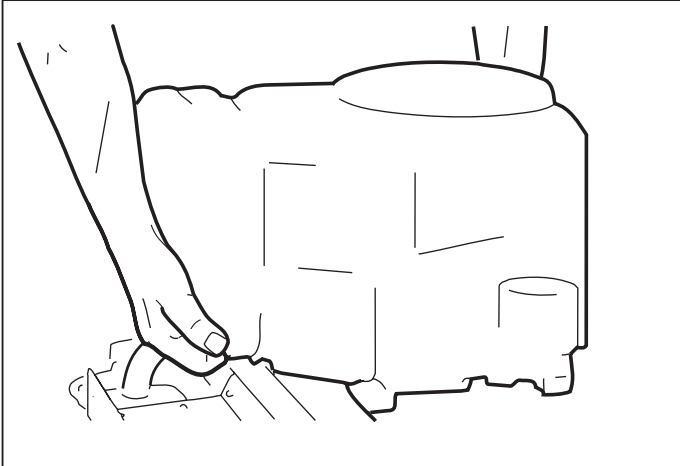

5.6.2 REMOVAL OF THE REAR AXLE

from 2001 to

page 1 / 3

5.6 REMOVAL OF THE REAR AXLE

The rear axle (Transaxle) is made up of single maintenance free sealed unit which includes the transmission unit (► mechanical or ► hydrostatic) and the differential.

It only needs to be removed to be replaced or for an overhaul by the Manufacturer's Service Centre.

➡ Remove the collector channel [see 5.3].

Place two spacers **(1)** of approximately 150 mm under the two ends of the rear plate.

➡ Remove the rear wheels [see 6.1].

The drive belt should also be loosened. This is done by ...

► **In mechanical drive models:** engaging the parking brake.

► **In hydrostatic drive models:** loosening the nut **(1)** of the stretcher.

Disconnect the blade engagement cable **(3)** by loosening the adjuster **(4)** and taking off the barrel **(5)** at the end of the fork **(6)**.

The dismantling procedure differs slightly depending on the various types of drives used.

► **In mechanical drive models:**

Dismantle the guide pulley **(7)** from the rear plate and detach the gear lever **(8)** by loosening the

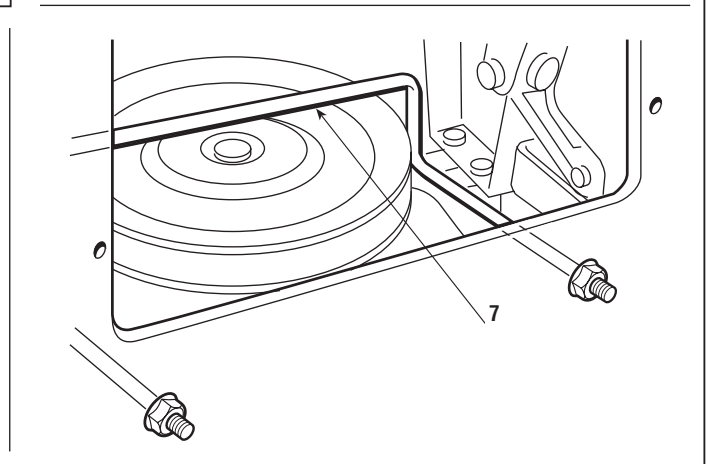
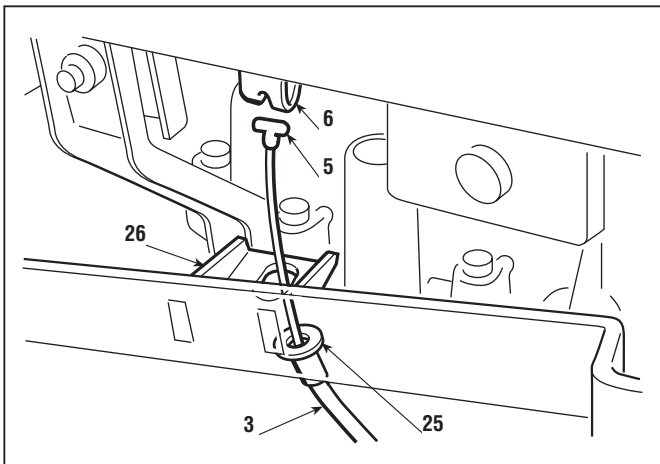
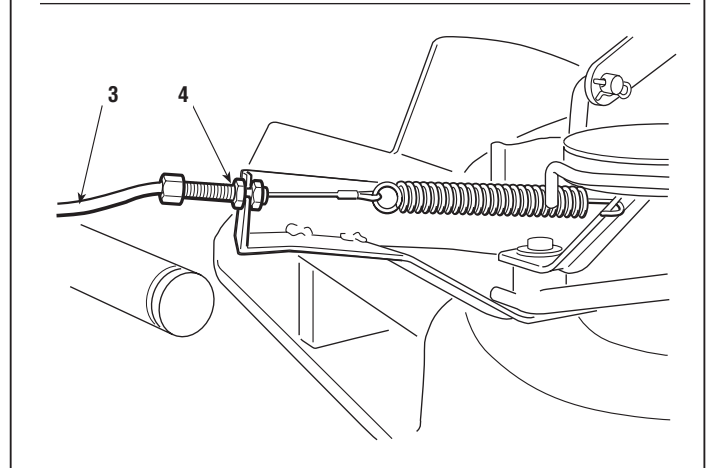
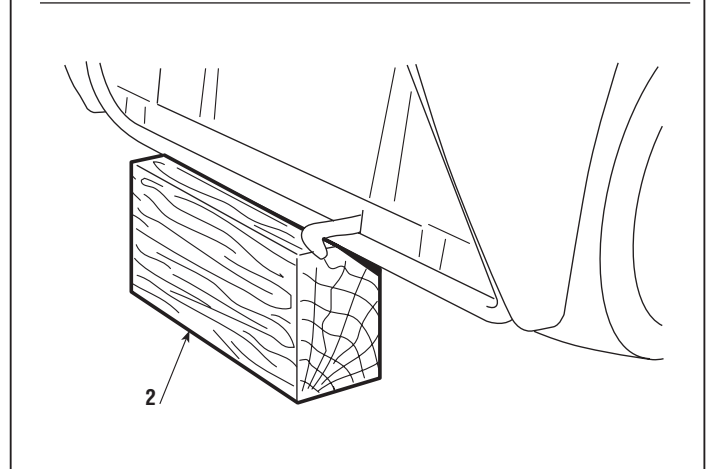
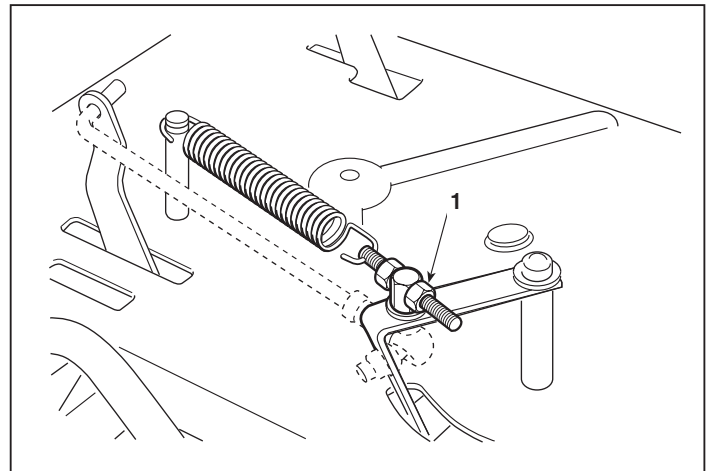

5.6.2 REMOVAL OF THE REAR AXLE

from 2001 to

page ◀ 2 / 3 ▶

screw (9) and the brake control rod (10). Then disconnect the cables from the microswitch signalling "neutral" (12).

The unit is supported by two brackets (13) with their screws (14) and (15) and is attached to the frame by four screws (16).

Loosen the two screws (14) to give a minimum of movement to the brackets (13) and undo the two screws (15). Then carefully loosen the four lower screws (16), holding up the unit so that it does not fall.

► **In the hydrostatic drive models:**

Dismantle the pin of the brake control rod (17) and the pin of the drive engagement control rod (18). Loosen the nut (19) of the release lever to detach the rod (20) from the lever (21).

The unit is held up by a support (22) and fastened to it by a screw with a nut (23), and it is attached to the frame by four screws (24).

Undo the nut (23) and then carefully undo the four lower screws (24), holding up the unit so that it does not fall.

To reassemble, reverse the order of the previous operations, taking particular care with the two self-tapping screws (15) which, if not screwed in correctly, could damage the threads inside so preventing it from being fastened properly.

When refitting the blade engagement cable, make sure that the washer (25) is correctly positioned between the bracket (26) and the cable sheath (3).

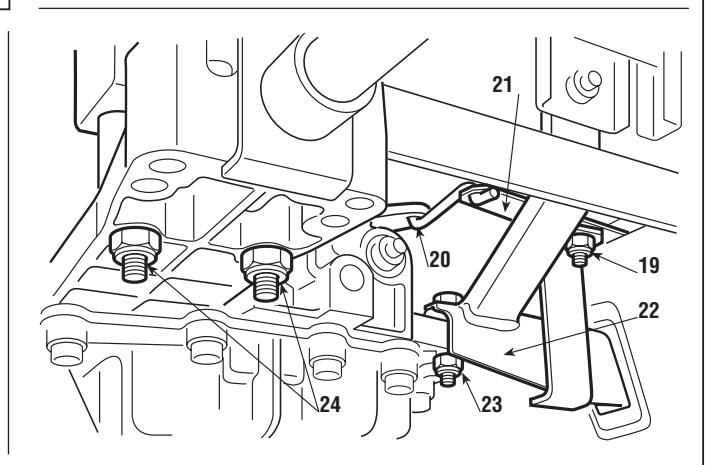
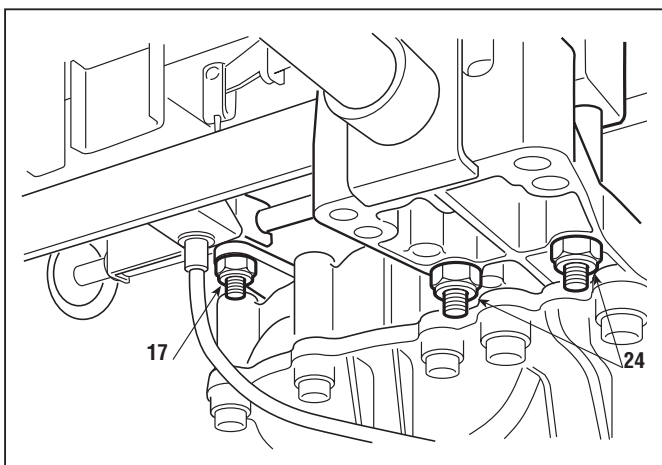
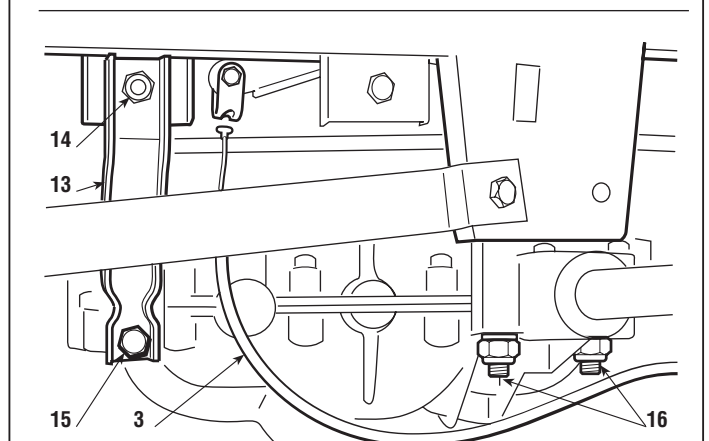
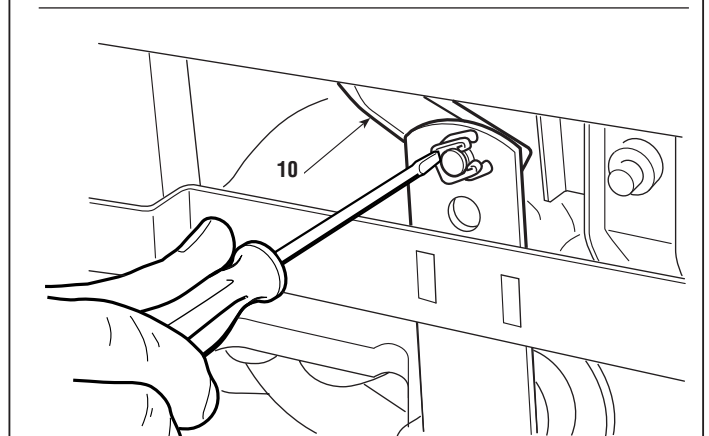
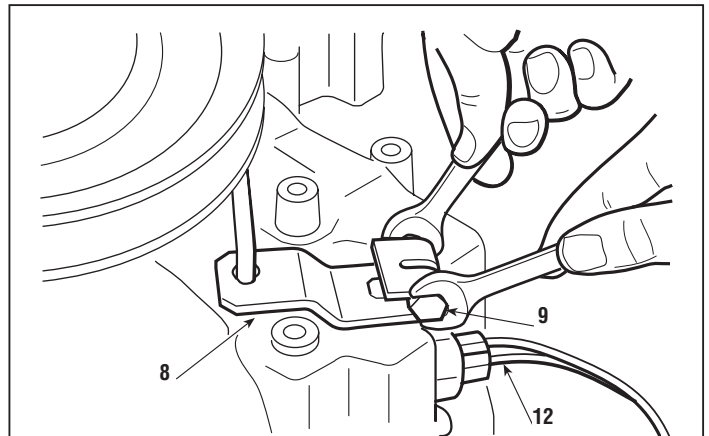

5.6.2 REMOVAL OF THE REAR AXLE

from 2001 to

page 3 / 3

Check that the spacers (31 – 32 – 33 – 34 – 35) are correctly fitted to the shafts, in the sequence given.

Reattach all the connections, and then ...

☛ Check the brake [see 4.3]

► **In hydrostatic drive models:** if the control rod has been replaced or completely pulled down:

☛ Adjust the travel and the position of “neutral” for the pedal [see 4.5].

☛ Reset the tension of the stretcher spring [see 4.4]. If only the front nut (1) has been loosened without having touched the rear one, the right tension will be achieved by just tightening up the nut (1).

When assembly is completed ...

☛ Refit the rear wheels [see 6.1].

☛ Refit the collector channel [see 5.3].

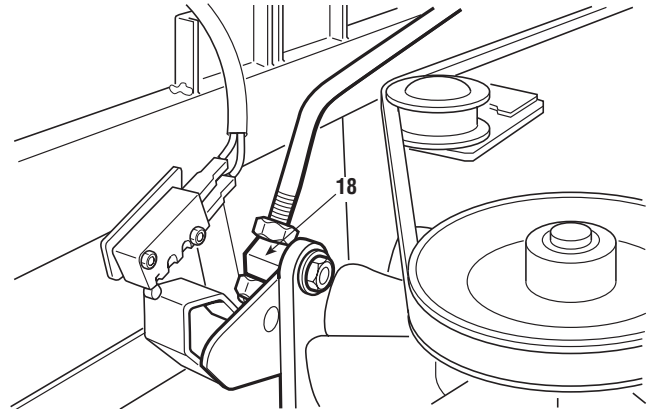

► **In mechanical drive models:**

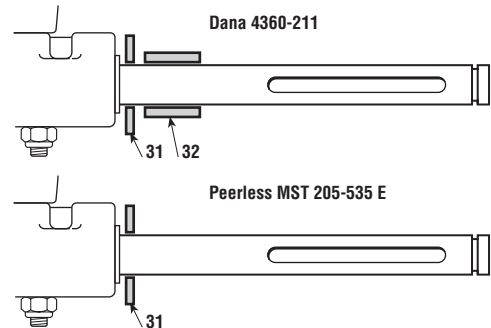

► **In hydrostatic drive models:**

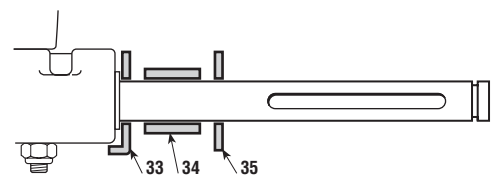

Tightening torques

14	Screws for brackets	25 ÷ 30 Nm
15	Self-tapping screws	25 ÷ 30 Nm
16-24	Screws for rear axle fastening ..	25 ÷ 30 Nm
23	Rear axle locknut	25 ÷ 30 Nm

5.7.2 REMOVAL OF THE CUTTING DECK

from 2003 to

page 1 / 1

5.7 REMOVAL OF THE CUTTING DECK

Removing the cutting deck facilitates all the overhaul and replacement of hubs, bearings and blade shafts.

With some practice and experience it is possible to do this work with the deck still in position.

➡ Remove the collector channel [see 5.3]

After moving the cutting height lever to position «1», loosen the engagement cable adjuster (1), pull it out and release the spring (2).

Loosen the screw (3), unfasten the safety pin (4) and move the fork to the side (5).

Turn the belt shifter (6) forward until the belt (7) is released from the pulley (8).

Unscrew the two nuts (9) fastening the two rods (10) to the frame and loosen the two nuts (11) fastening the deck.

Release the three split pins (12) holding the pins onto the lifting lever, being careful to not touch the nuts and locknuts so that, on reassembly it is as parallel as it was before.

Having checked that there is nothing in the way, the deck can be removed, taking it out towards the left so that all the pins come out of their positions.

To reassemble, reverse the order of the previous operations,

Reset the belt shifter (6) into position, refit the fork (5) with the relative safety pin (4) and fully tighten the screw (3).

➡ Reattach the collector channel [see 5.3].

➡ Check the alignment of the cutting deck [see 4.6].

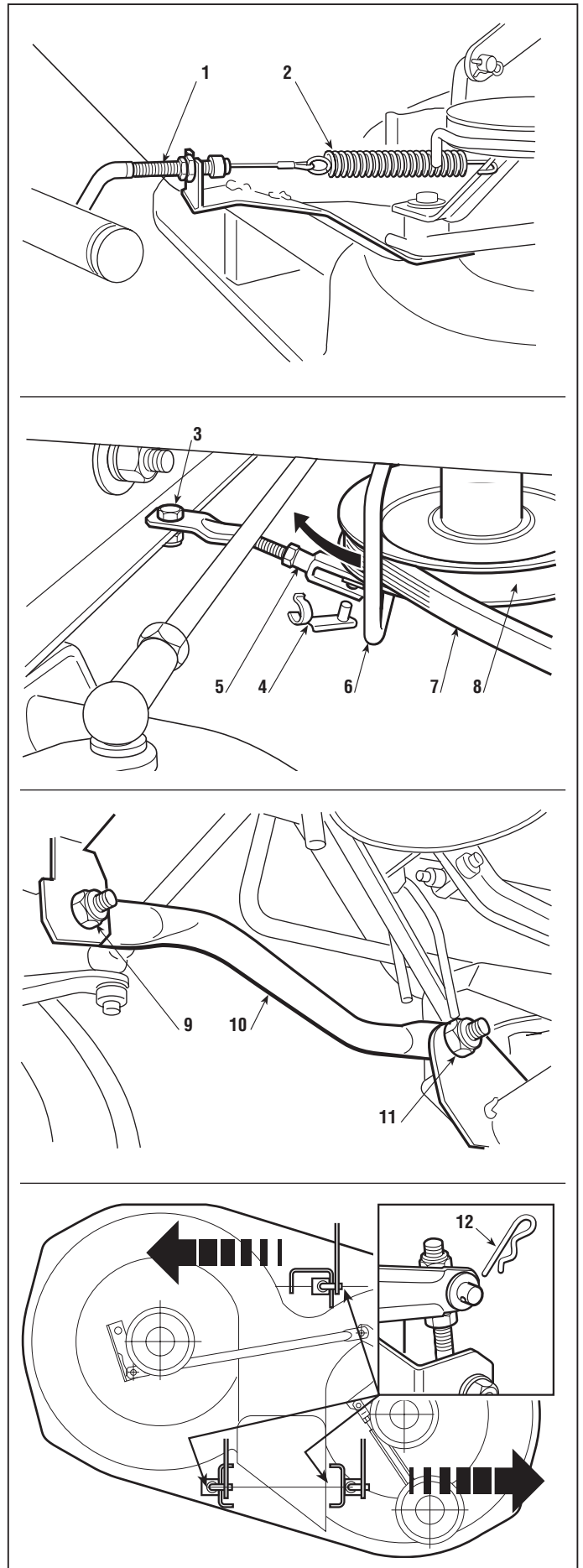

6.1.1 REPLACEMENT OF TYRES AND WHEELS

from 1997 to
page 1 / 1

6.1 REPLACEMENT OF TYRES AND WHEELS

A) Tyres

The tyres used are of the «Tubeless» type and so every repair of a hole in the tyre must be done by a tyre specialist according to the methods used for this type of tyre.

After replacing one or more tyres or the wheels, it is always necessary to check the pressure and to check the alignment of the cutting deck [see 4.6].



WARNING

Replace distorted wheel rims as they could impair the tyre's hold.

B) Wheels

The wheels are held by a snap ring (1) which can be removed with the help of a screwdriver.

NOTE

If a wheel is jammed onto the shaft, use a releasing spray directing around the splining hole.

On assembly it is advisable to spread grease on the shaft to facilitate the next wheel removal.

For the front wheels: replace the shoulder washer (2) and the flexible ring (1) with the bevel facing inwards.

For the rear wheels: replace the shoulder washer (2) and the flexible ring (1) with the bevel facing inwards and check the axial gap of the wheel on the shaft; if it is greater than 3 mm, a spacer (3) must be fitted between the wheel hub and the shoulder washer (2).

Tyre pressures

Front	1.5 Bar
Rear	1.2 Bar

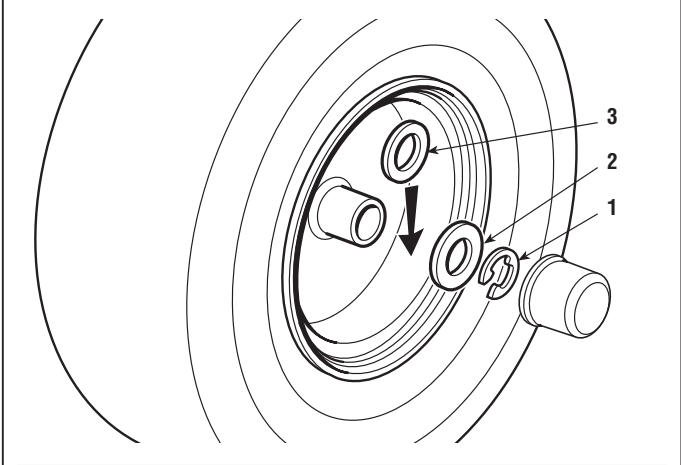
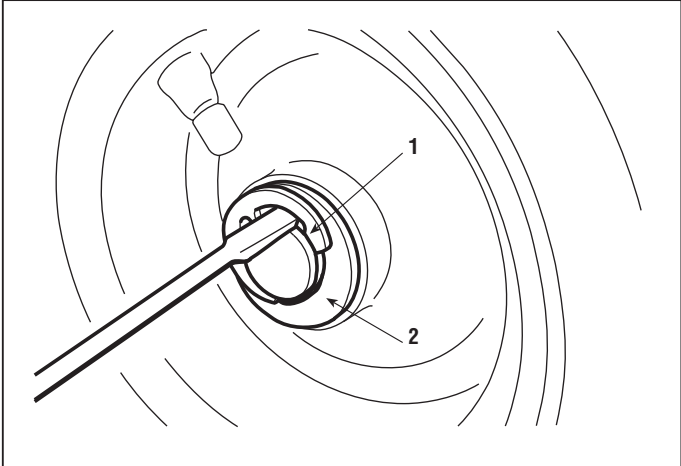

6.2.0 REPLACEMENT OF FRONT WHEEL BEARINGS

from 1997 to

page 1 / 1

6.2 REPLACEMENT OF FRONT WHEEL BEARINGS

➡ Dismantle the front wheel [see 6.1].

The front wheel bearings **(1)** are force splined into the front wheel hub.

To be able to remove a bearing a 10 - 12 mm round bar **(2)** is needed. Insert this from the opposite side and hammer it on various points around the internal circumference of the bearing.

The new bearing must be inserted with the help of a plastic mallet or a bronze pad **(3)** **working only on the outer ring of the bearing.**

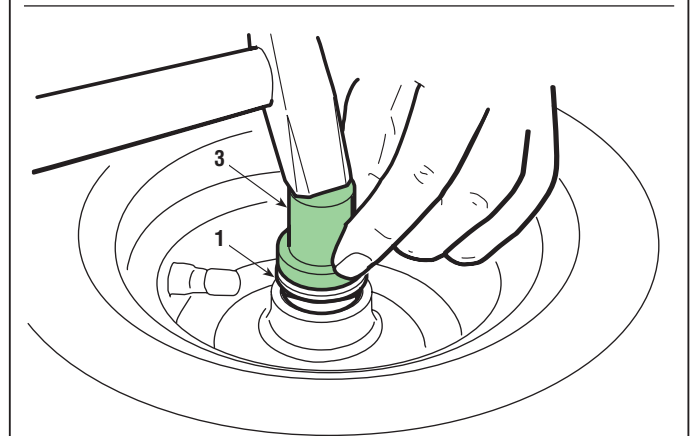
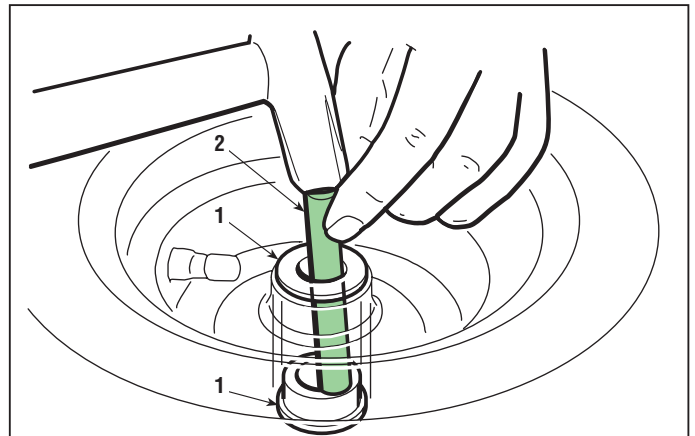

6.3.1 DISMANTLING OF THE STEERING COMPONENTS

from 2004 to

page 1 / 2

6.3 DISMANTLING STEERING COMPONENTS

➔ Remove the fuel tank [see 5.4].

To facilitate access to the parts concerned, it is best to loosen the drive belt.

This is done by ...

➤ **In mechanical drive models:** engaging the parking brake.

➤ **In hydrostatic drive models:** loosening the nut (1) of the stretcher. .

Unhook the spring (2) and lift the steering column (3) just enough to be able to draw out the pinion (4).

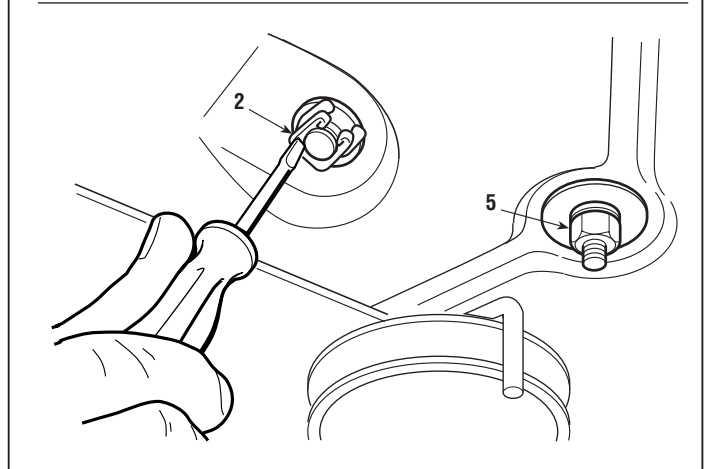
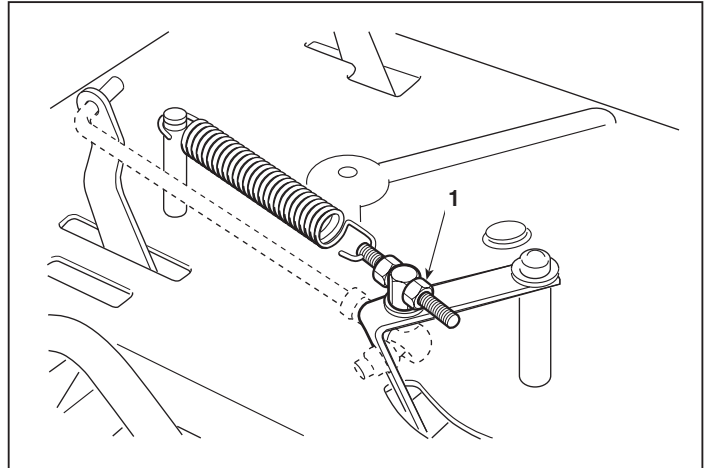

A) Dismantling steering pinion and ring gear

Unscrew the nut (5) and take out the whole ring gear shaft (6) after dismantling the tie-rod (7).

To dismantle the ring gear (6), take out the split pin (8c), undo the upper nuts (8a) and (8b) and take out the various components.

On reassembling be very careful to restore the exact sequence and to fully tighten the nut (9a) which holds the pin (10a).

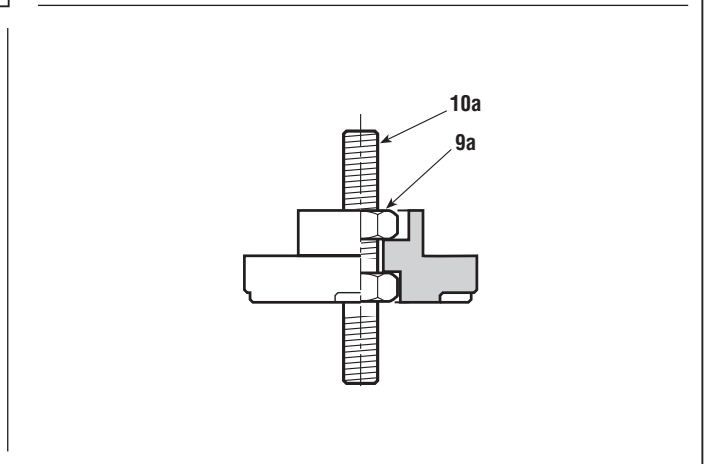
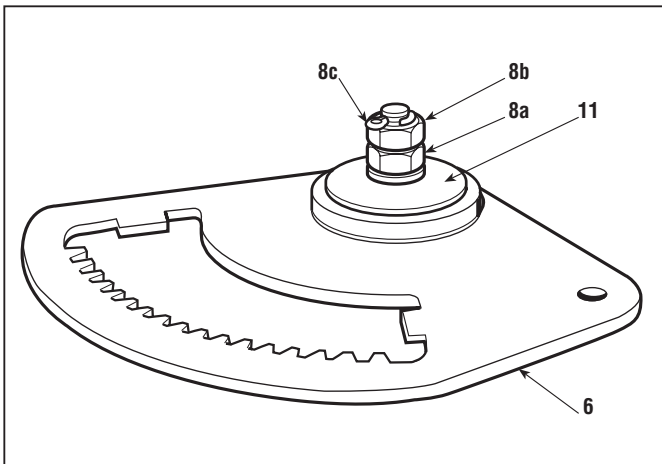
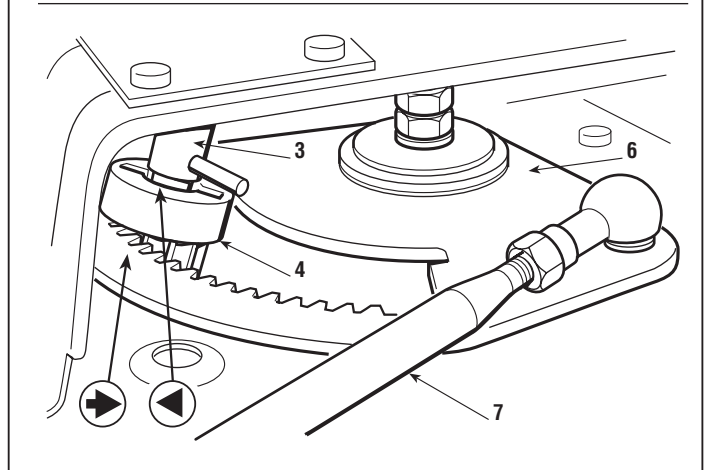

6.3.1 DISMANTLING OF THE STEERING COMPONENTS

from 2004 to

page 2 / 2

First screw down the nut (8a) without fully tightening it, so that the cup washer (11) can fulfil its purpose, that of allowing rotation without free play but sufficiently freed from the ring gear. Then fully tighten the locknut (8b) and insert the split pin (8c).



Reassemble the pinion and the ring gear shaft, lining up the two reference points (→ - ◀) punched on them, and making sure that the notch (12) on the frame slots into one of the housings in the bush. With a new pinion and ring gear it will be necessary to fit 2 blocks (13) of 0,8 mm between the ring gear bushing and the frame.

Put the whole assembly back together in the reverse order, bearing in mind that it is best to attach the ring gear before the pinion, and fully tighten the nut (5).

► **In hydrostatic drive models:** tighten the spring of the stretcher [see 4.4]. If only the front nut (1) has been loosened without having touched the rear one, the right tension will be achieved by just tightening up the nut (1).

B) Lower bush replacement

Use a universal socket wrench to unscrew the two screws (14) that fix the plate (15) and remove the spherical lower bush (16).

On reassembly ensure that the bush (16) is fitted with the protuberant part upwards.

Refit the plate (15) without tightening the screws (14).

Align the pinion with the crown wheel [see 6.3.A] and insert the end of the steering wheel column (3) in the hole in the spherical bush (16); fully tighten the screws (14) after having checked the correct alignment and regular rotation of the steering wheel column.

When reassembled ...

- ➡ Check the steering geometry [see 4.8].
- ➡ Refit the fuel tank [see 5.4].

Tightening torques

5	Nut for Ring gear	45 ÷ 50 Nm
9a	Nuts for the stud bolt	45 ÷ 50 Nm

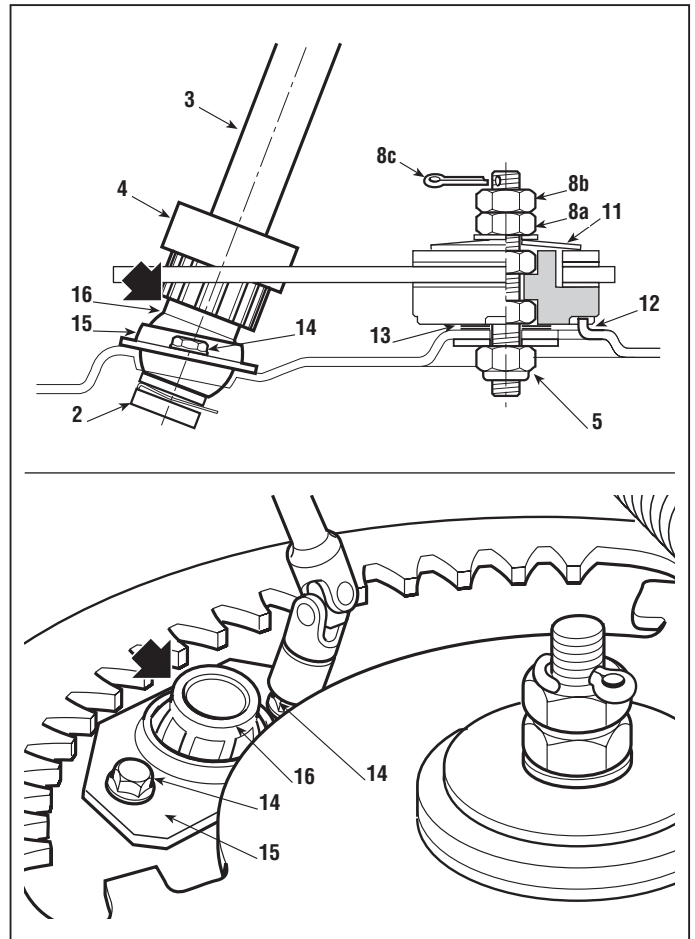

6.4.1 REPLACEMENT OF THE DRIVE BELT

from 2001 to

page 1 / 1

6.4 REPLACEMENT OF THE DRIVE BELT

- Dismantle the engine pulley [see 5.5] to release the belt.
- Remove the collector channel [see 5.3].

Loosen the nuts **(1)** holding the small side wheels **(2)** in order to release the belt, take off the drive pulley **(3)** and the stretcher pulley **(4)**, held on by the nuts **(5)** and **(6)**.

➤ **In mechanical drive models:** you need to dismantle the guide pulley **(7)** attached to the rear plate.

➤ **In the hydrostatic drive models:** in order to remove the belt, detach the brake control rod **(8)** by dismantling the pin **(9)** from the lever **(10)**.

When reassembling, make sure that the belt **(11)** is correctly positioned in the pulleys inside the rims [see 8.2.4], taking particular notice of where it passes through the fork **(12)**.

Always refit the dust covers **(13)** of the wheels **(2)**.

When reassembled, ...

- Refit the engine pulley [see 5.5].
- Adjust the drive engagement [see 4.4].
- Refit the collector channel [see 5.3].

Tightening torques

1 Nuts for small wheels.....	25 ÷ 30 Nm
5 - 6 Nuts for pulleys	25 ÷ 30 Nm

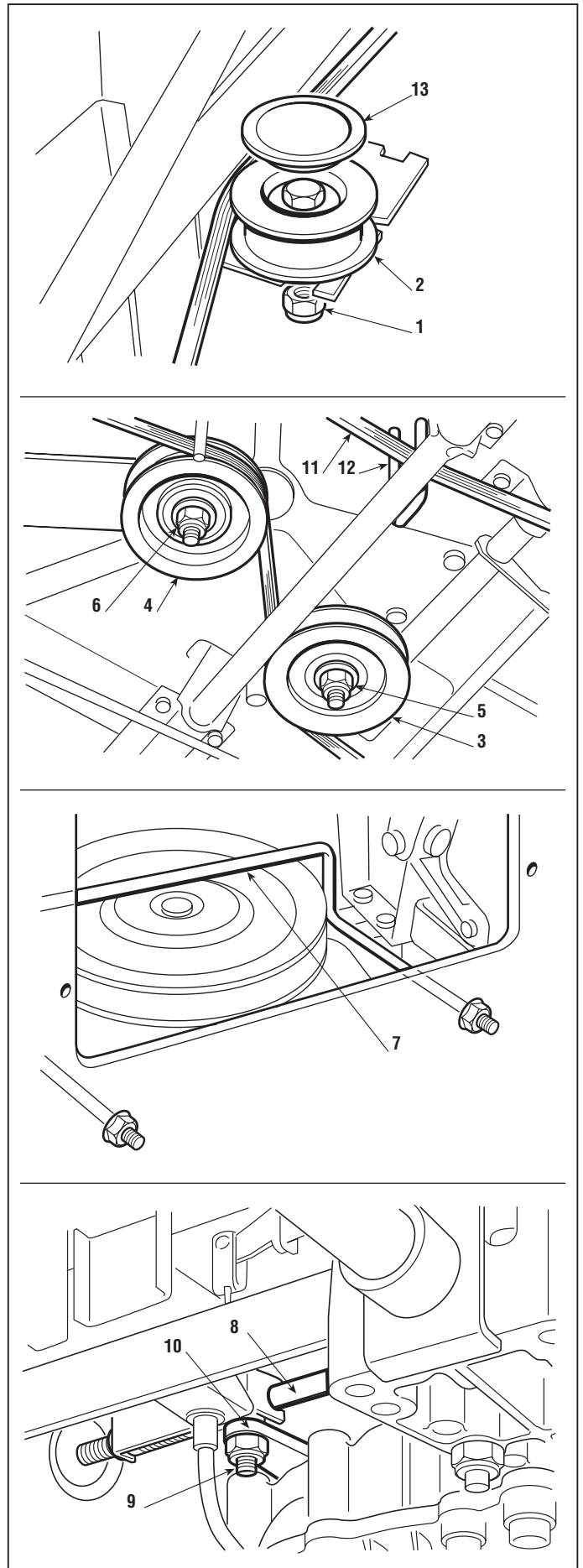

6.5.1 - REPLACEMENT OF THE SMALL WHEELS FOR THE DRIVE BELT

from 2001 to

page 1 / 2

6.5 REPLACEMENT OF THE SMALL WHEELS FOR THE DRIVE BELT

Remove the collector channel [see 5.3].

For better access to the parts concerned the drive belt should also be slackened. This is done by ...

► **In mechanical drive models:** engaging the parking brake

► **In hydrostatic drive models:** loosening the stretcher nut (1)

The two wheels (2) are held onto the frame by two nuts (3), with a spacer in between (4).

When reassembling, there should be kept in mind that:

- the tall spacer (4a) is to be fitted beneath the right-hand wheel (2a - 2c);
- the short spacer (4b) is to be fitted beneath the left-hand wheel (2b - 2d);

► **In mechanical drive models:** the left wheel (2b) must be fitted to the front support of the frame [see 8.2.4];

► **In hydrostatic drive models:**

The position of the right-hand wheels (2c) and left-hand wheels (2d) is determined by the different use of the hole in the plate (5) screwed onto the frame [see 8.2.4].

When reassembly is completed, tighten the nuts (3) to the amounts shown.

Always refit the dust covers (5) of the wheels (2).

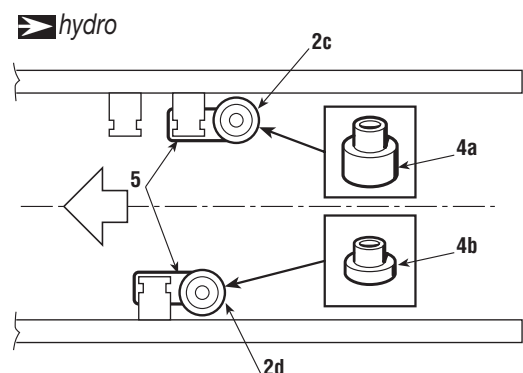
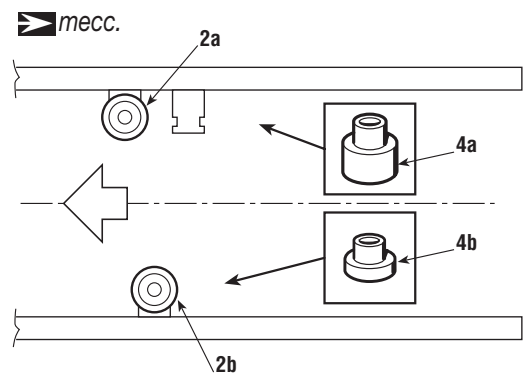
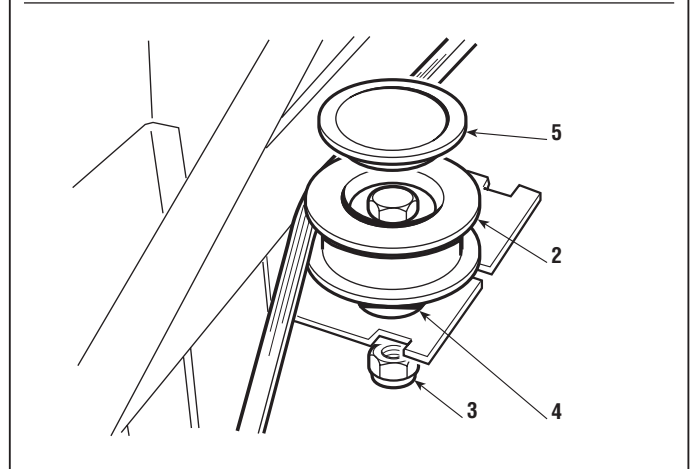
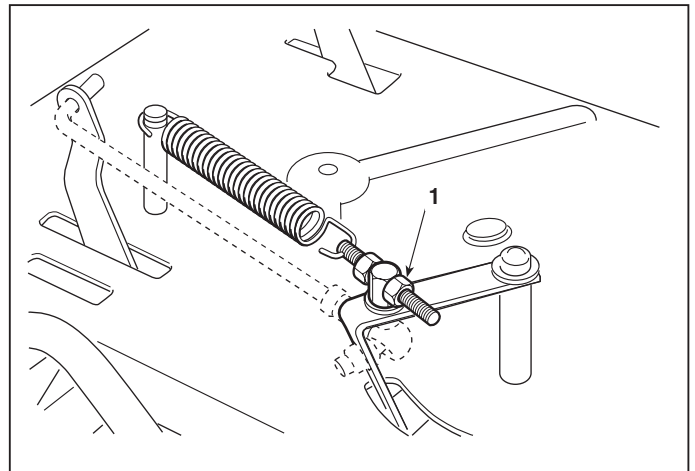

	6.5.1 - REPLACEMENT OF THE SMALL WHEELS FOR THE DRIVE BELT		from 2001 to
			page  2 / 2

Lastly ...

- Adjust the drive engagement [see 4.4].
- Refit the collector channel [see 5.3].

➤ ***In hydrostatic drive models:*** reset the tension of the stretcher spring [see 4.4]. If only the front nut **(1)** has been loosened without having touched the rear one, the right tension will be achieved by just tightening up the nut **(1)**.

Tightening torque

3 Nuts for small wheels..... 25 ÷ 30 Nm

6.6.1 REPLACEMENT OF THE BLADES BELT

from 2003 to

page 1 / 1

6.6 REPLACEMENT OF THE BLADES BELT

Loosen the screw (1), unfasten the safety pin (2) and move the fork (3) to the side.

Turn the belt shifter (4) forward by enough to free the belt (5) from the pulley (6).

Set the cutting plate in the lowest position, to obtain greater accessibility and disengage the blades to slacken off the belt.

Remove the right-hand protective cover (7) by unscrewing the nut (8) and loosening the screws (9).

Remove the left cover (10) fixed by two screws (11).

Release the left spring (12) and loosen the left guide pulley (13).

Release the right spring (14) loosen the nut (15) of the idle pulley and take off the guide pulley (16) after having released the spring (17).

At this point the brake shoes can be manually moved away from the pulley and the belt can be taken off and renewed.

On reassembling, take care to exactly position the new belt in the pulley rims [see 8.2.5].
Reset the belt shifter (4) into position, refit the fork (3) with the relative safety pin (2) and fully tighten the screw (1).

Once assembly is completed ...

➔ Adjust the blade engagement [see 4.1].

Tightening torque

15 Nut for idle pulley 25 ÷ 30 Nm

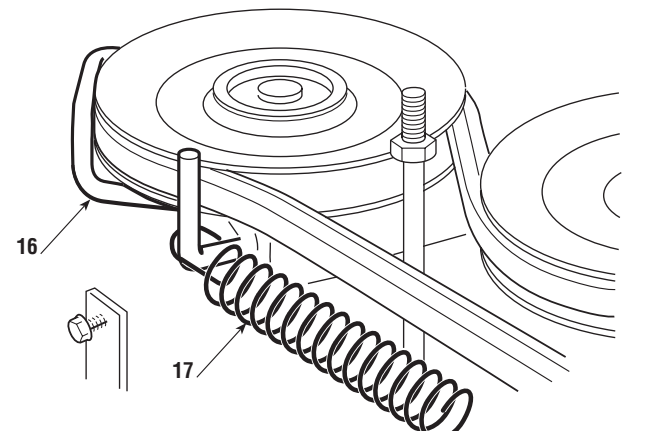
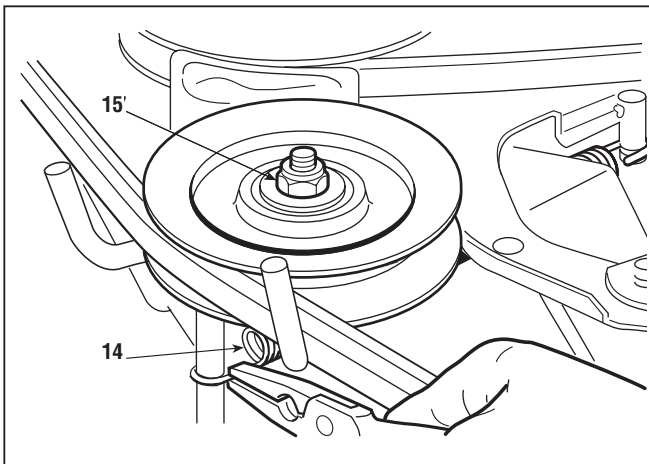
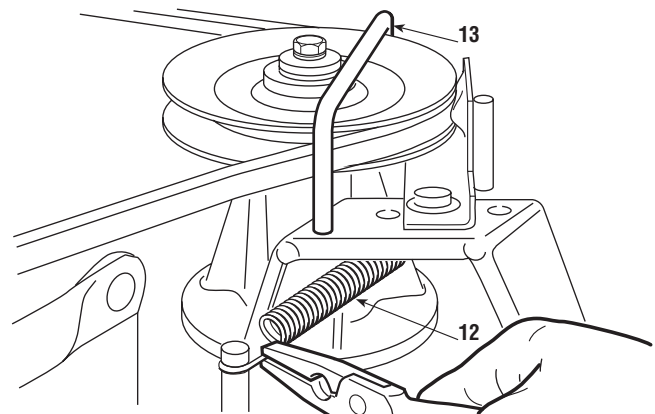
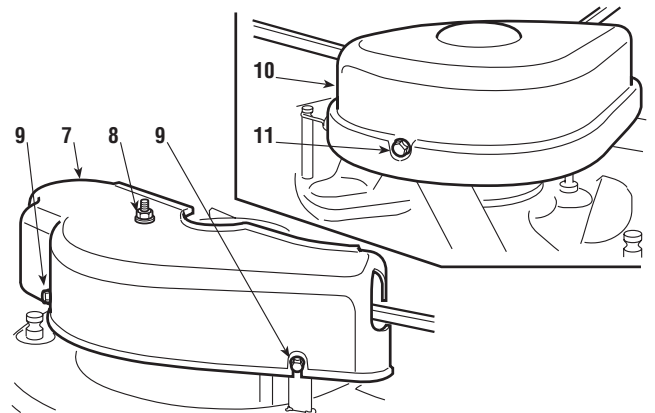
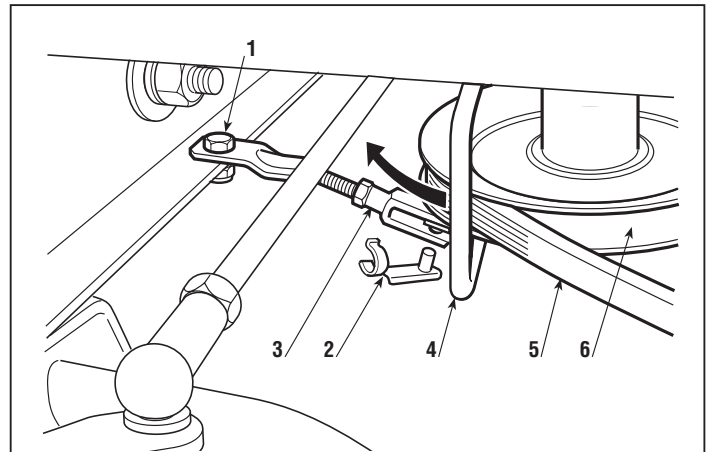

<p>6.7.0 REPLACEMENT OF THE LIFTING CABLE</p>	<p>from 1997 to page 1 / 1</p>
--	------------------------------------

6.7 REPLACEMENT OF THE LIFTING CABLE

➡ Remove the collector channel [see 5.3].

Put the deck at the minimum cutting height, loosen and release the adjuster **(1)** and loosen the nut **(2)** for the drive pulley **(3)** in order to be able to take off the cable **(4)**.

Put the deck at the maximum height so that the toothed sector turns to the back. Pass the cable along the groove and insert the end **(5)** in the housing.

Put the cable back in its path around the pulley, hook on the adjuster **(1)** and tighten the pulley nut **(2)**.

When reassembled ...

➡ Adjust the alignment of the deck [see 4.6.A].

➡ Refit the collector channel [see 5.3].

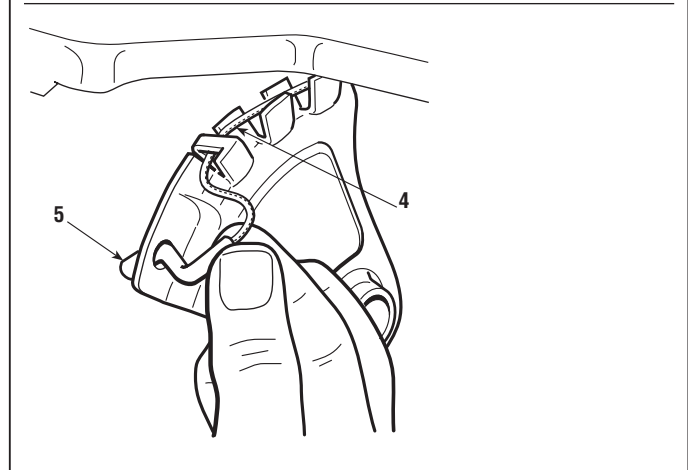
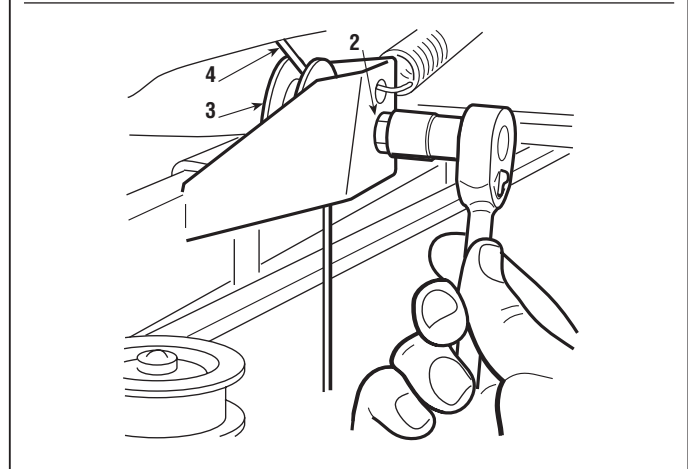
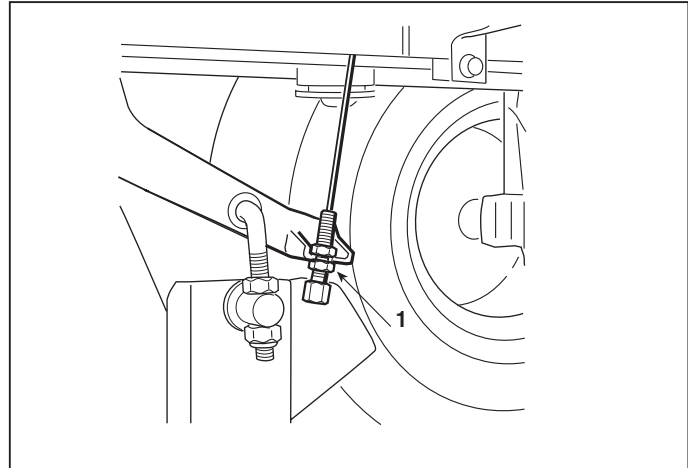

6.8.0 - REPLACEMENT OF THE BLADES ENGAGEMENT CABLE

from 1997 to

page 1 / 1

6.8 REPLACEMENT OF THE BLADES ENGAGEMENT CABLE

➡ Remove the right-hand rear wheel [see 6.1].

With the cutting deck in the lowest position and the lever in the disengaged position, loosen the adjuster **(1)**, remove it from its housing and unhook the spring **(2)**.

Take off the barrel **(3)** at the end of the fork **(4)** which is near the joint for the lever, and take out the whole cable **(5)**.

On reassembling, make sure that the washer **(6)** is positioned between the bracket **(7)** and the cable sheath **(5)**.

Once assembly is completed ...

➡ Adjust the blade engagement [see 4.1].

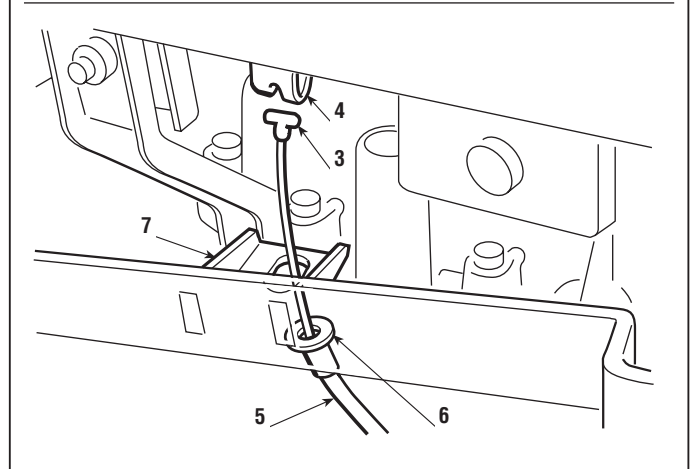
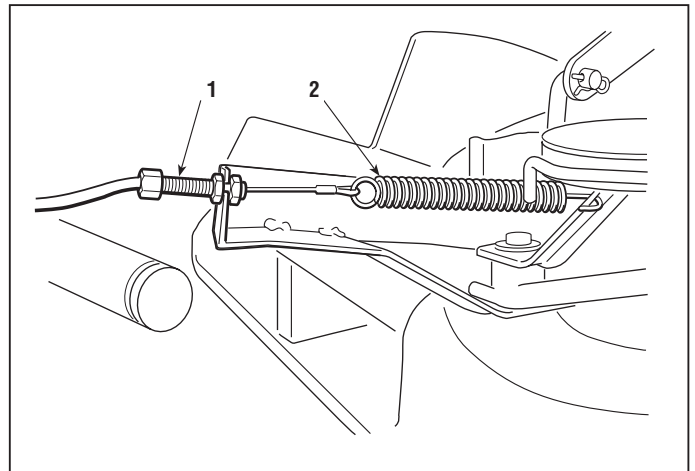

6.9.0 - REPLACEMENT OF THE SUPPORTS AND SHAFTS OF THE BLADES

from 1997 to

page 1 / 2

6.9 REPLACEMENT OF THE SUPPORTS AND SHAFTS OF THE BLADES

➔ Remove the cutting deck [see 5.7].

NOTE

This operation is not strictly necessary since, with a little practice and experience, it is possible to dismantle the deck supports without removing the deck.

➔ Remove the blades [see 4.10] and take off the hubs.

Remove the right-hand cover (1) by unscrewing the nut (2) and loosening the screws (3). Take off the left-hand cover (4) held by two screws (5).

Release the two springs (7) and (8) of the right and left brakes and take off the left guide pulley (6).

At this point it is possible to undo the central screws (9) and to take off the pulleys (10).

Dismantle the flange support (11) by unscrewing the three nuts (12).

The entire support (11), including shafts and bearings, is a spare part available as single assembly unit.

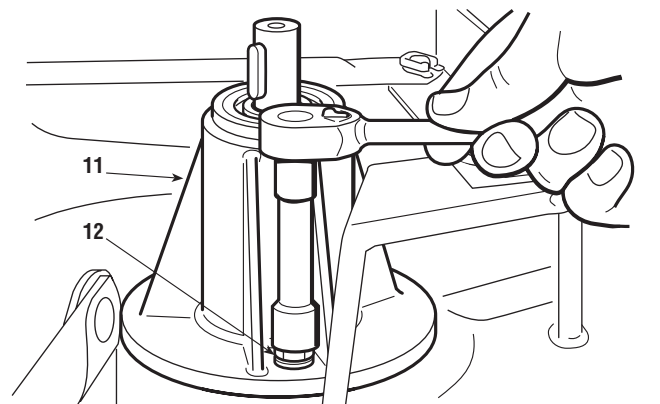
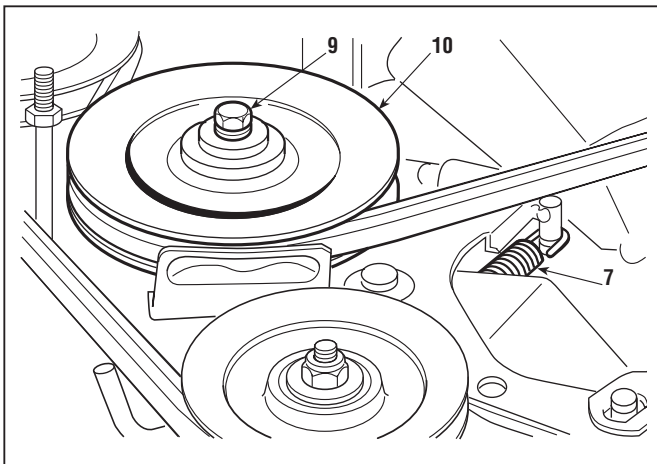
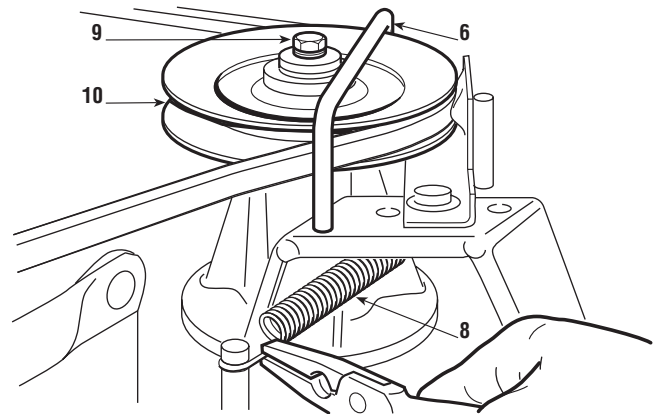
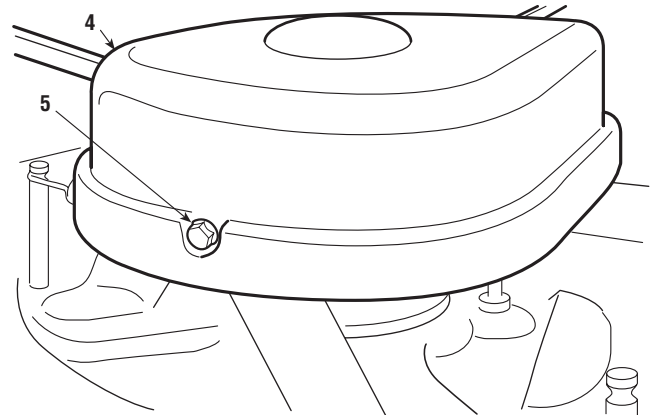
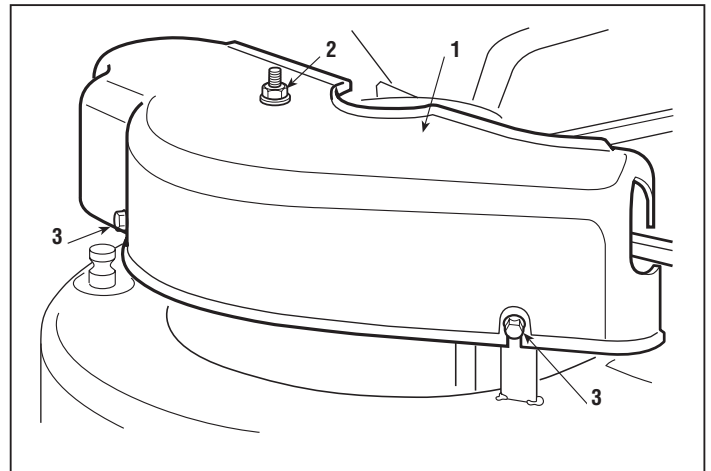

6.9.0 - REPLACEMENT OF THE SUPPORTS AND SHAFTS OF THE BLADES

from 1997 to

page 2 / 2

If you should want to just replace the shaft or bearings, remove the key (13) and hit the shaft with a plastic mallet on the pulley side in order to remove the shaft together with the lower bearing (14).

After having removed the snap ring (15), the dust cover (16) and the spline (17), the bearing (14) splined onto the shaft can be removed using a normal extractor, taking care to close up the threaded hole (18) with a screw to prevent the point of the extractor from damaging the thread.

The second bearing still in place must be removed by hitting it from the inside of the flange using a 12 ÷ 15 mm diameter round bar (19).

On reassembling, first put the shaft into the hole of the lower bearing and insert this into the support. Fit on the upper bearing and, using the special bush (20) which works on the inner ring, hit it squarely with a mallet until the bearing is fully driven home.

The right and left shafts seem to be the same, but can be differentiated as follows:

- **right shaft:** red paint on the pulley side;
- **left shaft:** green paint on the pulley side.

Before refitting the support assembly, check that these positions are correct.

Fit the flange supports onto the deck, **fully tightening the nuts (12).**

Tightening torques

9	Screws for pulleys fastening	20 ÷ 25 Nm
12	Nuts for flanged support	25 ÷ 30 Nm

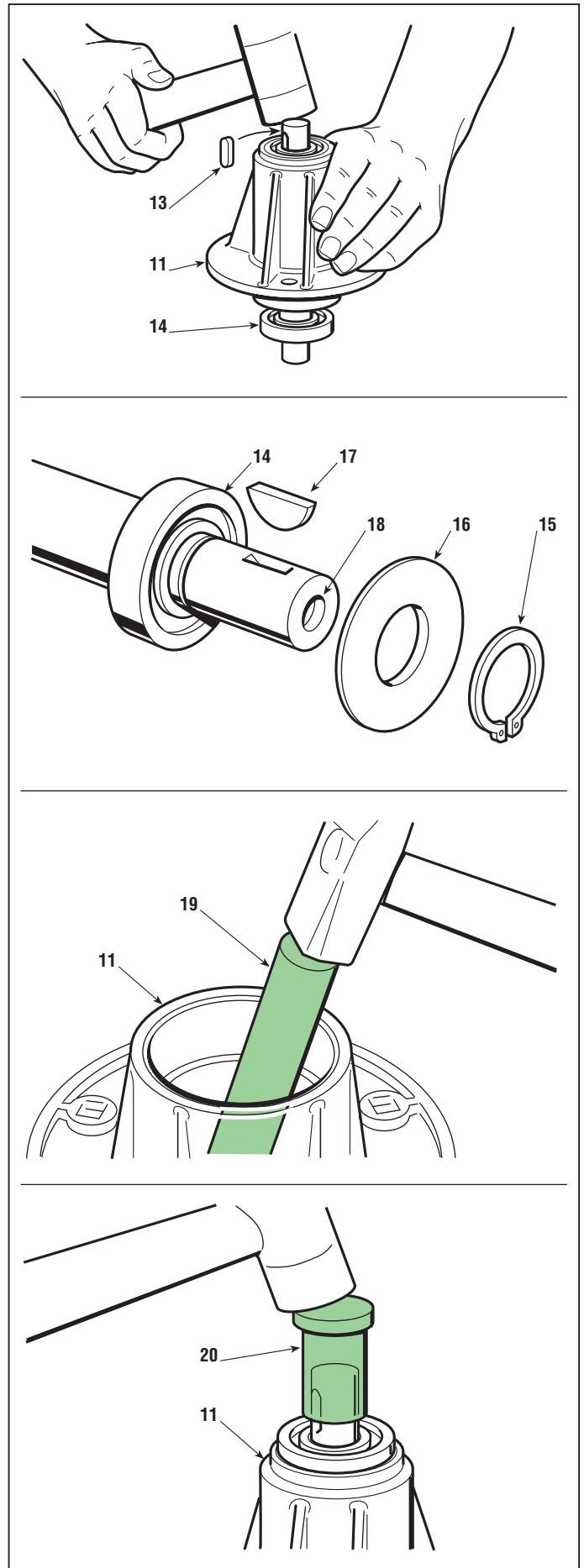

6.10.0 REPLACEMENT OF THE ACCELERATOR

from 1997 to

page 1 / 1

6.10 REPLACEMENT OF THE ACCELERATOR

➔ Remove the fuel tank [see 5.4].

Take off the steering wheel by taking out the pin (1) and remove the dashboard held on by three screws (2) and by another two screws (3) on top of the electronics card.

Take off the knob (4) and disconnect the wire (5) from the connection terminal (6) on the engine. Undo the two screws (7) and take out the accelerator together with the wire.

On reassembling, put the accelerator lever in the «MINIMUM» position, connect the end of the wire (5) to the terminal (6) on the engine after having moved the cursor (8) in the same «MINIMUM» position specific to each type of engine and shown in the instruction booklet.

When assembly is completed ...

➔ Refit the fuel tank [see 5.4].

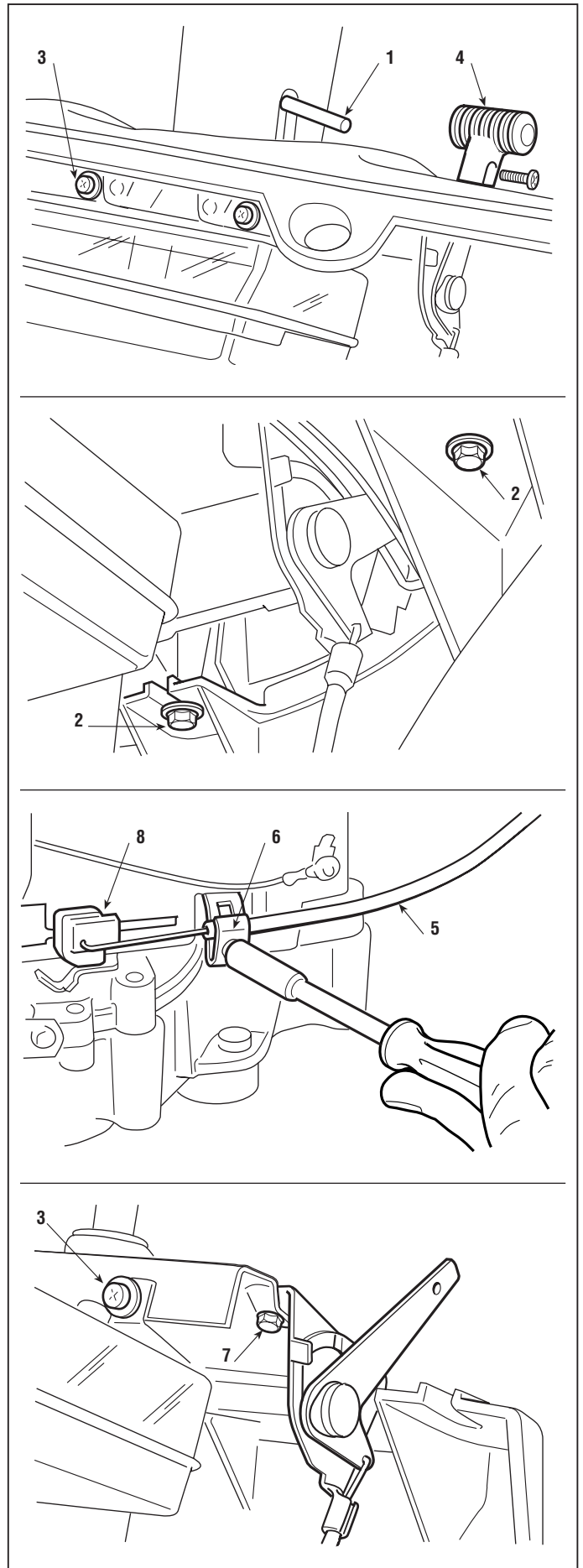

6.11.1 REPLACEMENT OF THE BRAKE PADS AND DISC

from 1997 to

page 1 / 1

6.11 REPLACEMENT OF THE BRAKE PADS AND DISC (► *In mechanical drive models*)

➡ Remove the left-hand rear wheel [see 6.1].

Disconnect the control rod (1) from the lever (2) and undo the two screws (3) which hold on the support (4).

The support (4) contains a pad (5a) separated from the control pistons (6) by a plate (7).

The other pad (5b) can be reached by taking off the disc (8).

If there is oil on the pads, clean with solvent and go over them with fine-grade abrasive paper.



Both pads should be replaced if the depth of either of them is less than 5 mm.



Renew the disc if it is damaged, distorted or less than 4 mm thick.

On reassembly, carefully reposition all the components and refit the complete support. When connecting the rod (1) be sure to use the upper hole in the lever (2).

NOTE

During all these operations it is better to not unscrew or loosen the central screw (9) to avoid altering the calibration of the cam driving the pistons.

If it has been moved, the lever's free movement will have to be checked [see 4.3].

When fully reassembled ...

➡ Check the brake adjustment [see 4.3].

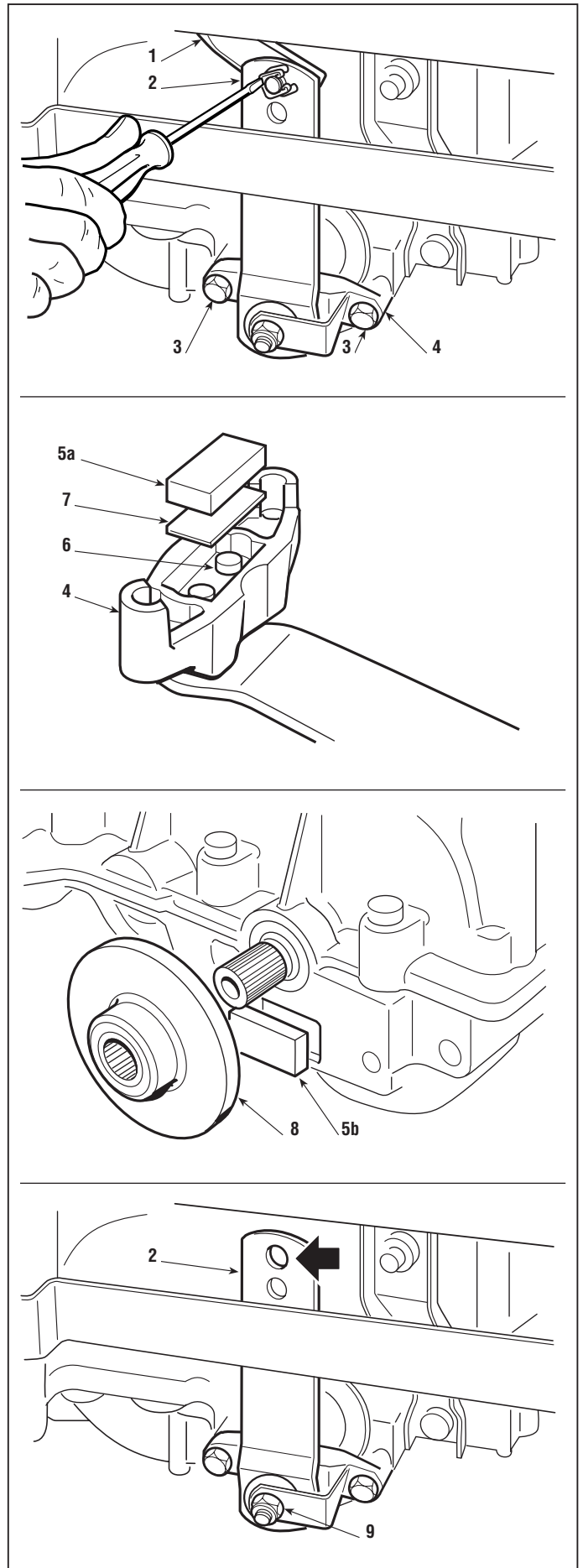

7.1.2 - GUIDE TO THE IDENTIFICATION OF PROBLEMS IN THE ELECTRICAL SYSTEM

from 2006 to
page 1 / 3

7.1 GUIDE TO THE IDENTIFICATION OF PROBLEMS IN THE ELECTRICAL SYSTEM

In the following some of the problems connected to the malfunctioning of the electrical system are shown, with their probable cause and the remedial action to be taken. Should the problem continue after the appropriate checks, seek assistance from your local Service Centre.

Faulty electronic cards must always be replaced without trying to repair them or replace single components.

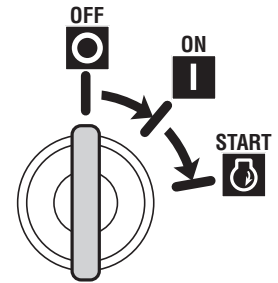

PROBLEM	CAUSE	REMEDY
1. Activation of the self-resetting protection ¹⁾		
a).... on inserting the key in position «ON»	Battery terminal crossed	Check the battery connections
	Short circuit to earth	Check the connectors and wiring of the microswitches.
b) ... in position «START» or after a few seconds' use:	Sulphated battery (it no longer accepts recharging)	Replace the battery
	Faulty or wet electronic card	Check and dry with low pressure tepid air (hair-dryer)
	Disconnected or missing battery	Reconnect the battery, which must always be connected
	Battery terminals corroded or with poor contact	Check and clean the connections
c) ... after several minutes' use:	Poor or missing earth contact on the charge regulator	Check the earth connections and the screws fastening the regulator
	Overvoltage from a malfunction in the regulator	Check the recharge circuit [see 7.8]
	Battery disconnected or faulty during use	Check the battery or wiring
2. With the key in the «ON» position the pilot lamp remains off	The battery is not supplying the card	Check the connection cables Check the battery's condition [see 7.9]
	Battery or card not earthed to frame	Check and put right
	6.3 A fuse blown	Replace fuse (6.3 A - delayed)
	Battery terminal crossed	Check connections. WARNING! In this case, the card is irreparably damaged and you need to replace it since it is no longer usable!
3. The pilot lamp comes on but, with the key in the «START» position, the starter motor does not turn or lacks power (poor starting)	The battery is not supplying sufficient current	Recharge the battery [see 7.9]
	Badly earthed battery, or the starter relay or motor not earthed	Check and put right
	Defect in the starter relay	Check that the starter relay is activated [see 7.6]

¹⁾ Activation of the self-resetting protection of the electronic card is signalled by the failure of the LED to light, by it switching off during work, by the engine running erratically or stopping.

7.1.2 - GUIDE TO THE IDENTIFICATION OF PROBLEMS IN THE ELECTRICAL SYSTEM

from 2006 to

page ◀ 2 / 3 ▶

PROBLEM	CAUSE	REMEDY
4. The pilot lamp is flashing with the key in the «START» position and the starter motor does not turn	Starting not permitted [see summary logic table 7.2]	After checking that the conditions are met, check all the microswitches [see 7.3] and the relative wiring.
	Malfunction in the electronic card	Try replacing the card with one that is known to work
5. The starter motor turns but the engine does not start	No fuel flow	Check the leads for the carburettor solenoid valve opening control (if provided) or check the fuel stopcock and filter.
	Impaired starter system	Check that spark plug caps are positioned correctly
		Check that the spark plug electrodes are clean and have the correct gap.
6. The starter motor continues to turn after engine has started, and does not stop when the key is removed	Mechanical difficulties with the contact breakers of the starter relay	Replace the starter relay.
	Starter works erratically for mechanical or electrical reasons taking excessive current and causing binding of relay contacts	Check the starter motor
7. The starter motor operates as soon as the key is in the «ON» position, and can be turned off only by removing the key (pilot lamp on)	Fault in the card	Replace the card
	Starter block operating faults	Replace the block
8. The pilot lamp does not come on when the key is in the «ON» position but the machine works	Fault in the electronic circuit or in the signalling LED	Replace the card (NOTE: You can finish the work in any case, but you need to replace the card or signalling LED as soon as possible)
9. The pilot lamp becomes weak after several hours' work	Insufficient charge	Check that the charging cable has not detached
		Check that there are no current leakages caused by cables with damaged insulation
		Check that the regulator is working properly [see 7.8]
	Charger fuse blown	Replace fuse (25 A) and check the recharge circuit [see 7.8]
10. The engine stops while in use for reasons not due to the safety devices cutting in	The safety devices have cut in or are faulty	Check the microswitch's operation and the relevant wiring [see 7.3 and 7.7]
	Accidental detaching of an electrical wire	Check all wiring
	Starting of engine not permitted [see summary logic table 7.2]	After checking that the conditions are met, check all the microswitches [see 7.3] and the relative wiring.

7.1.2 - GUIDE TO THE IDENTIFICATION OF PROBLEMS IN THE ELECTRICAL SYSTEM

from 2006 to

page 3 / 3

PROBLEM	CAUSE	REMEDY
11. The 6.3 A fuse blows	Short circuit or overload on the power side of the electronic card (start-up unit, starter relay) lights and recharger connector	Find and replace the defective user [see 7.4 and 7.6]
	Short circuit or damage to the electronic card protection (power side)	Try changing the card with one that is known to work. If the problem stops, replace the faulty card
12. The 25 A fuse blows	Faults in the battery charging circuit	Replace fuse (25 A) and check the recharge circuit [see 7.8]
13. No audible signal for the "grass-catcher full" condition	Malfunctioning or faulty blades microswitches and grass-catcher signalling	Check the microswitches and wiring. WARNING! – Check that the blade microswitch stops the engine or prevents it from being started if the acknowledgement conditions are not met [see 7.2]
	Malfunctioning or faulty electronic card	Try changing the card with one that is known to work. If the problem stops, replace the faulty card.

7.2.1 - SUMMARY TABLE FOR THE CUTTING IN OF THE SAFETY DEVICES

from 2005 to

page 1 / 1

7.2 SUMMARY TABLE FOR THE CUTTING IN OF THE SAFETY DEVICES



This table shows the various situations in which the safety devices intervene.

-/- = Uninfluential

A) STARTING («START» position)

OPERATOR	GRASS-CATCHER	BLADES	DRIVE	PARKING	ENGINE	PILOT LAMP
-/-	-/-	-/-	Engaged	-/-	DOES NOT start	Flashing
-/-	-/-	Engaged	-/-	-/-	DOES NOT start	Flashing
Absent	-/-	-/-	-/-	Disengaged	DOES NOT start	Flashing

B) WHILE CUTTING

OPERATOR	GRASS-CATCHER	BLADES	DRIVE	PARKING	ENGINE	PILOT LAMP
Absent	-/-	-/-	Engaged	-/-	Stops	ON
Absent	-/-	Engaged	-/-	-/-	Stops	ON
-/-	Missing	Engaged	-/-	-/-	Stops	ON
-/-	-/-	Engaged	-/-	Engaged	Stops	ON
Absente	-/-	-/-	-/-	Disengaged	Stops	ON

7.3.2 - SAFETY MICROSWITCHES OPERATION CHECK AND SWITCHES

from 2006 to

page 1 / 1

7.3 SAFETY MICROSWITCHES OPERATION CHECK AND SWITCHES

This check is made by detaching all the connectors and by using the tester in the Ohm-meter function. This operation should be done, without the driver on board, by making contact with the ferrules on the contacts of the female connector of the wiring **(1)** and should give this result:

N° Contacts	Tester reading and condition		
GRASS-CATCHER ATTACHED MICROSWITCH			
3 - 6 (CN2)	∞ (without g.catc.)	O (with g.catcher)	
SEAT MICROSWITCH			
3 - 5 (CN2)	∞ (absent)	O (seated)	
PARKING MICROSWITCH			
3 (CN2) - 1 (CN5)	O (free)	∞ (engaged)	
BLADE MICROSWITCH			
3 - 4 (CN2)	∞ (engaged)	O (disengaged)	
"IN NEUTRAL" SIGNAL			
3 - 1 (CN2)	∞ (drive)	O (neutral)	
GRASS-CATCHER FULL MICROSWITCH			
2 (CN2) - Massa	O (full)	∞ (empty)	
STARTER UNIT			
+ Battery - 2 (CN3)	∞ (OFF)	O (ON)	O (START)
+ Battery - 3 (CN3)	∞ (OFF)	∞ (ON)	O (START)

ENGINE STOP

This operation must be done by making contact between the ferrules of the electronic card **(2)**, keeping all the connectors attached, and should give this result:

N° Contacts	Tester reading and condition
5 (CN3) - Earth	O (Always)

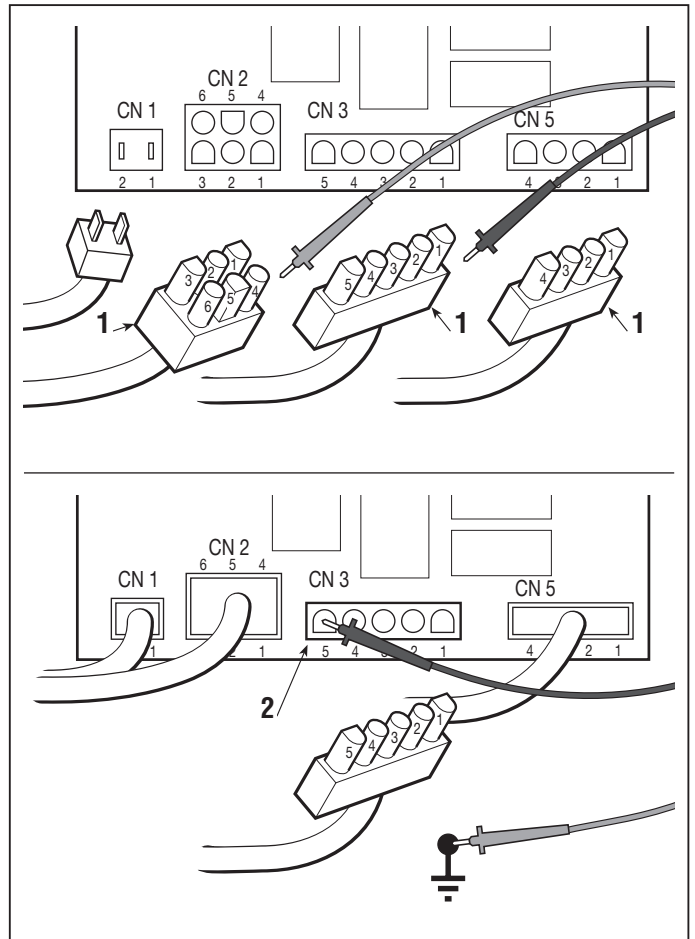

7.4.2 TERMINAL BOARD SUPPLY CHECK

from 2006 to

page 1 / 1

7.4 TERMINAL BOARD SUPPLY CHECK

This check is done with the tester in voltmeter function (Volt DC 0 ÷ 20), with the black ferrule on terminal 3 (CN5) and the red ferrule on terminal 2 (CN3) the wiring connectors (1).

- The key in the «ON» position.

The reading shows the battery voltage, which should never go below 11 Volts.

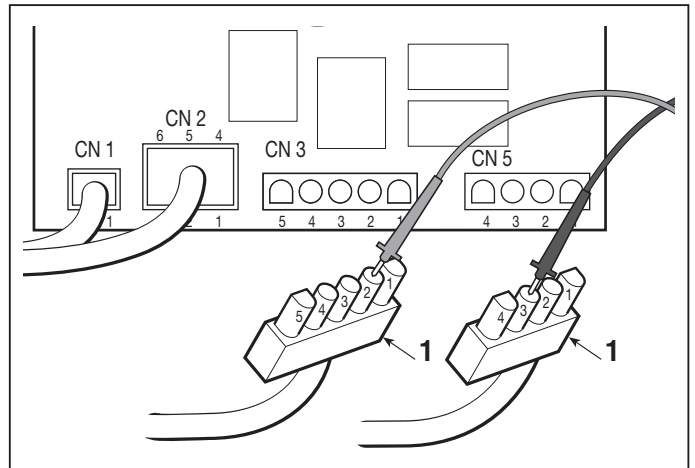

7.6.2 STARTER RELAY OPERATION CHECK

from 2006 to
page 1 / 1

7.6 STARTER RELAY OPERATION CHECK



WARNING! – Remove the cap of the sparking plug (or plugs), since the safety systems that normally prevent accidental starting of the engine are cut out when the checking procedure is carried out.

To do this requires:

- engaging the parking brake;
- disengaging the blade;
- the key in the «ON» position.

Disconnect the connector CN3.

In making a bridge between the terminals 2 and 4 (CN3) of the wiring connector **(1)**, the click of the relay bobbin should be heard and the starter motor should come into action.

► **Only with B&S and Tecumseh engines:**

If the relay clicks but the starter motor does not go, make a bridge **(2)** with a large section cable (5 mm²) between the power contacts of the relay.

If the starter motor comes into operation, look for the fault within the relay or replace it. Otherwise, check the starter motor together with its wiring.

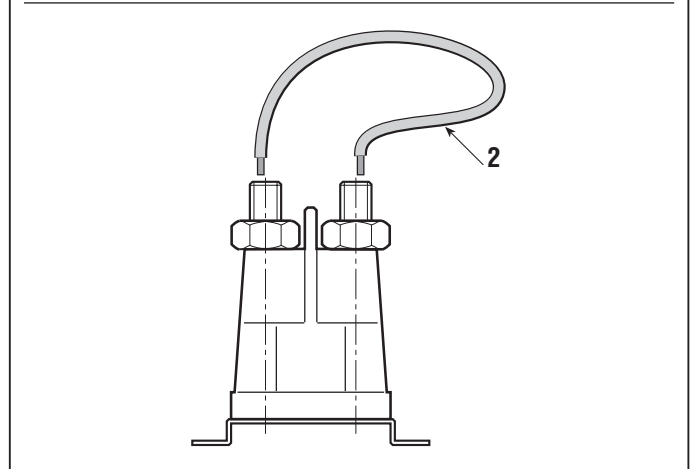
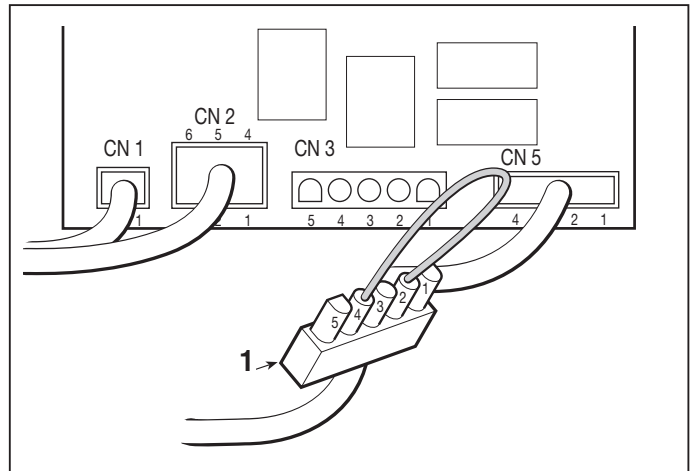

7.7.2 ELECTRONIC CARD OPERATION CHECK

from 2006 to

page 1 / 1

7.7 ELECTRONIC CARD OPERATION CHECK

A) Card supply

To make this test it is necessary to have:

- The key in the «ON» position
- Connector CN2 (1) disconnected from the card, with all the other connectors attached.

In this situation the pilot lamp should come on.

If the indicator light goes out when connector (1) is inserted, the earth connections of the microswitches must be checked.

B) Safety and service supply check

This check is done with the tester in the Voltmeter function (Volt DC 0 ÷ 20), with the black ferrule to earth and the red one on terminal 3 (CN2) of the card's connector (2).

- The key in the «ON» position.

The reading on the tester shows the battery's voltage.

C) Checking the operation of the self-setting protection

For this test, put everything in the same situation as in point "A".

By connecting terminal 3 of the CN2 connector of the **electronic card (3)** to the frame's earth, the pilot lamp should go out due to the protection cutting in. Eliminating the connection to earth, the pilot lamp should come on again.

NOTE

During this test, the self-setting protection reaches very high temperatures (around 160 °C) which are to be considered normal. Similarly, there might be some smoke inside the transparent box which is due to the overheating of the powder inside.



WARNING! Do not touch this component of the card until it has cooled down.

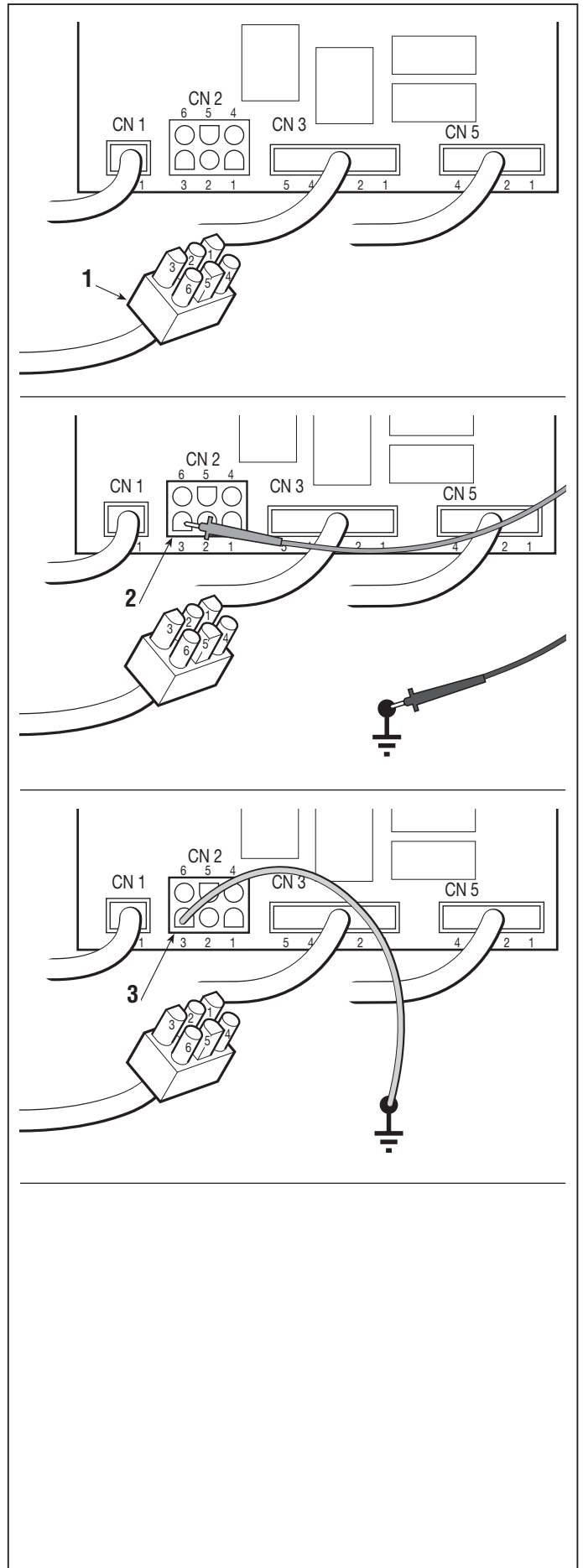

 	7.8.2 RECHARGE CIRCUIT CHECK	 	from 2006 to page 1 / 1
--	---	--	----------------------------

7.8 RECHARGE CIRCUIT CHECK

The job of the voltage regulator is to supply a flow of current to the battery at a constant voltage of about 14 - 15 Volts, cutting in every time that the output voltage from the generator exceeds this threshold.

A faulty regulator may recharge the battery insufficiently (therefore needing frequent recharging) or, otherwise, may supply overloading that causes the self-resetting protection to cut in.

Before checking the recharge circuit, make sure that:

- all connections are correct;
- the earth connections are firmly connected, especially the earth connections to the regulator;
- the battery is charged and not sulphated [see 7.9];
- the charger fuse is not blown.

A) Checking the lower charging limit

Start the engine and keep running at minimum (with the headlights on - ► *if fitted*).

With the voltmeter tester, measure the voltage at the battery terminals. If the value does not rise but tends to fall, even slowly, it means that the regulator is not charging sufficiently and must be replaced.

If the voltmeter shows no value it means that the charger fuse is blown.

► **Only with a Honda engine:** check the recharge relay. On moving the key from «OFF» to «ON» and vice versa, the ticking of the relay contacts should be heard; otherwise it should be replaced.

B) Checking the upper charging limit

Start the engine and take it to maximum speed. With the tester in the voltmeter function, measure the voltage at the battery terminals. The amount should rise and settle at 14-15 Volts after about 10-15 minutes.

If this level is exceeded to a point where the engine stops due to the self-resetting protection device cutting in (at about 16 Volts), it means that the regulator is charging too much and must be replaced.

◀	7.9.1	▶	from 1997 to
◀	CARE AND MAINTENANCE OF THE SEALED BATTERY	▶	page 1 / 1

7.9 CARE AND MAINTENANCE OF THE SEALED BATTERY

A) General information

In a sealed “dual” battery, the electrolyte for each element is carefully measured out during manufacture and sealed at source, in order to ensure maximum performance during the battery’s entire life.

With a battery of this type, it is not necessary to add water or acid, and the cover must never be opened or removed.

B) Recommendations for correct use

To keep the battery performing at optimum levels and to increase its life, various precautions should be taken:

- always keep the battery fully charged;
- always recharge a flat battery within 1 month, otherwise the elements could be damaged and no longer able to take the charge (sulphated);
- always recharge the battery before and after periods of prolonged inactivity or storage.

C) Rules for recharging the battery

Recharging is a particularly important operation for the life of the battery and must be carried out according to these instructions:

- do not recharge the battery when its case is broken or damaged;
- carefully read the instructions for using the battery charger and the battery;
- use the appropriate battery charger;
- recharge at a room temperature of between 10° and 30°C;
- check that the battery does not heat to beyond 50°C while recharging. If it should do so, stop recharging immediately and dispose of the battery since it will be unusable.

With the battery disconnected (and at rest for at least 12 hours) and the tester in voltmeter function, measure the voltage between the terminals. The amount given (open circuit voltage) gives an indication of the operations to be carried out, as per the following table:

Battery voltage with open circuit	Battery state	Operation to be carried out
> 12.6 Volts	Fully charged	None
< 12.4 Volts	Low charge	Recharge

Check the battery voltage at least 12-24 hours after recharging.

7.10.1 FITTING SAFETY MICROSWITCHES

from 2003 to

page 1 / 1

7.10 FITTING SAFETY MICROSWITCHES



IMPORTANT

If the microswitches are to function correctly, it is important to follow the exact assembly positions by referring to the drawings that indicate the various usages of each type.

A = Free

B = Activated

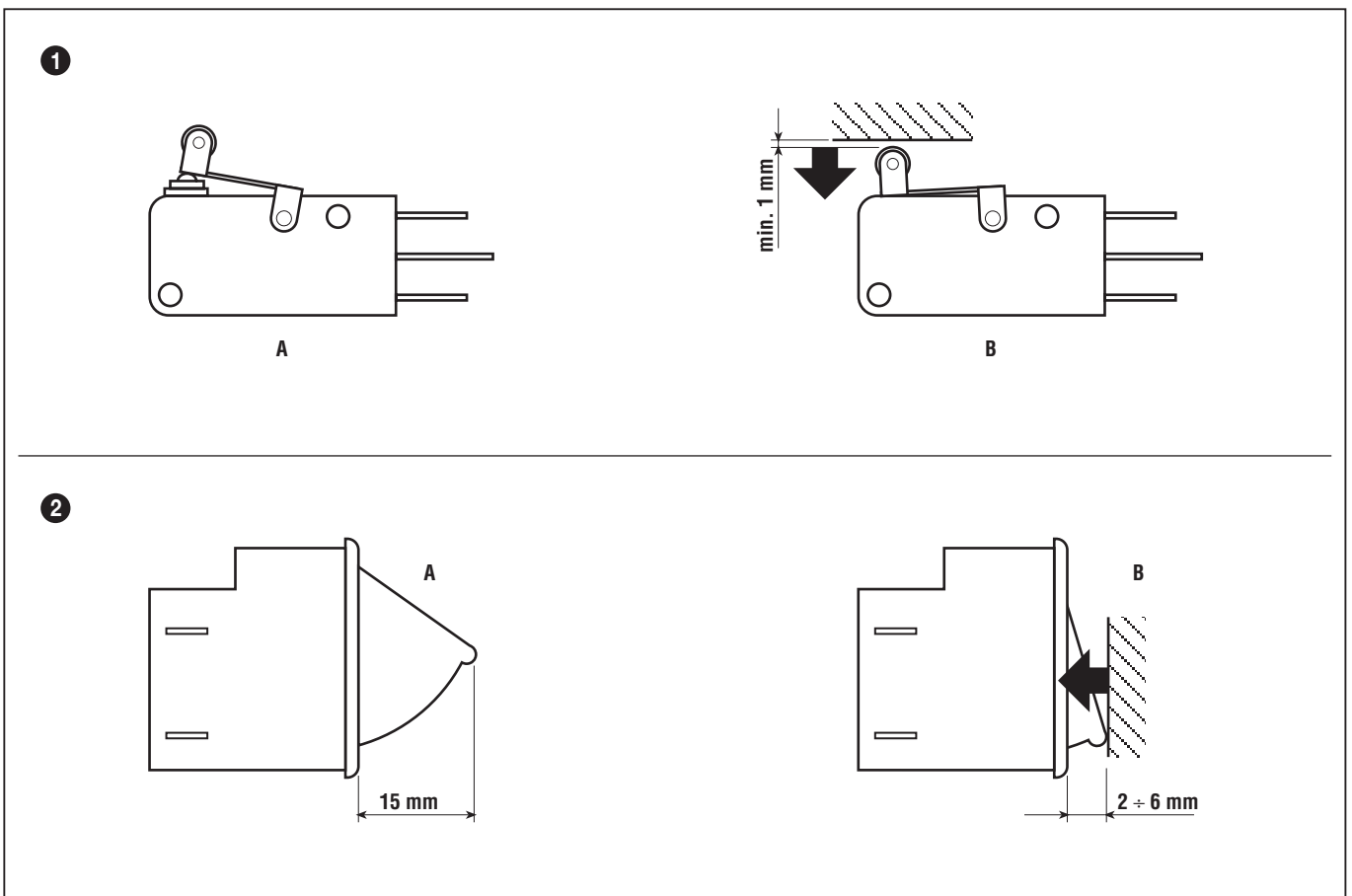

Adjust the seat safety microswitch **(1)** only by changing the position of the cam **(2)**, after loosening the two fixing screws **(3)**.

This adjustment is correct when you have checked the following:

A = seat free: the lower edge of the cam **(2)** should be touching the microswitch button without activating it.

B = seat with the driver in position: the lateral edge of the cam **(2)** should press the push-button, leaving at least 2-3 mm more travel.

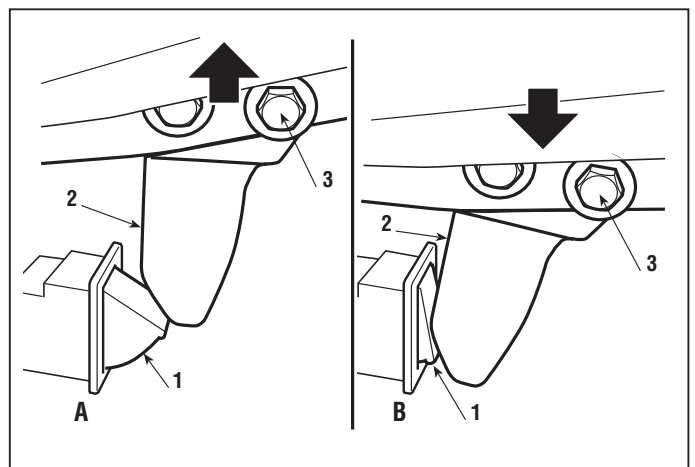

7.11.3 ELECTRICAL DIAGRAMS

from 2006 to

page 1 / 2

1 Engines B&S - Tecumseh - Kohler

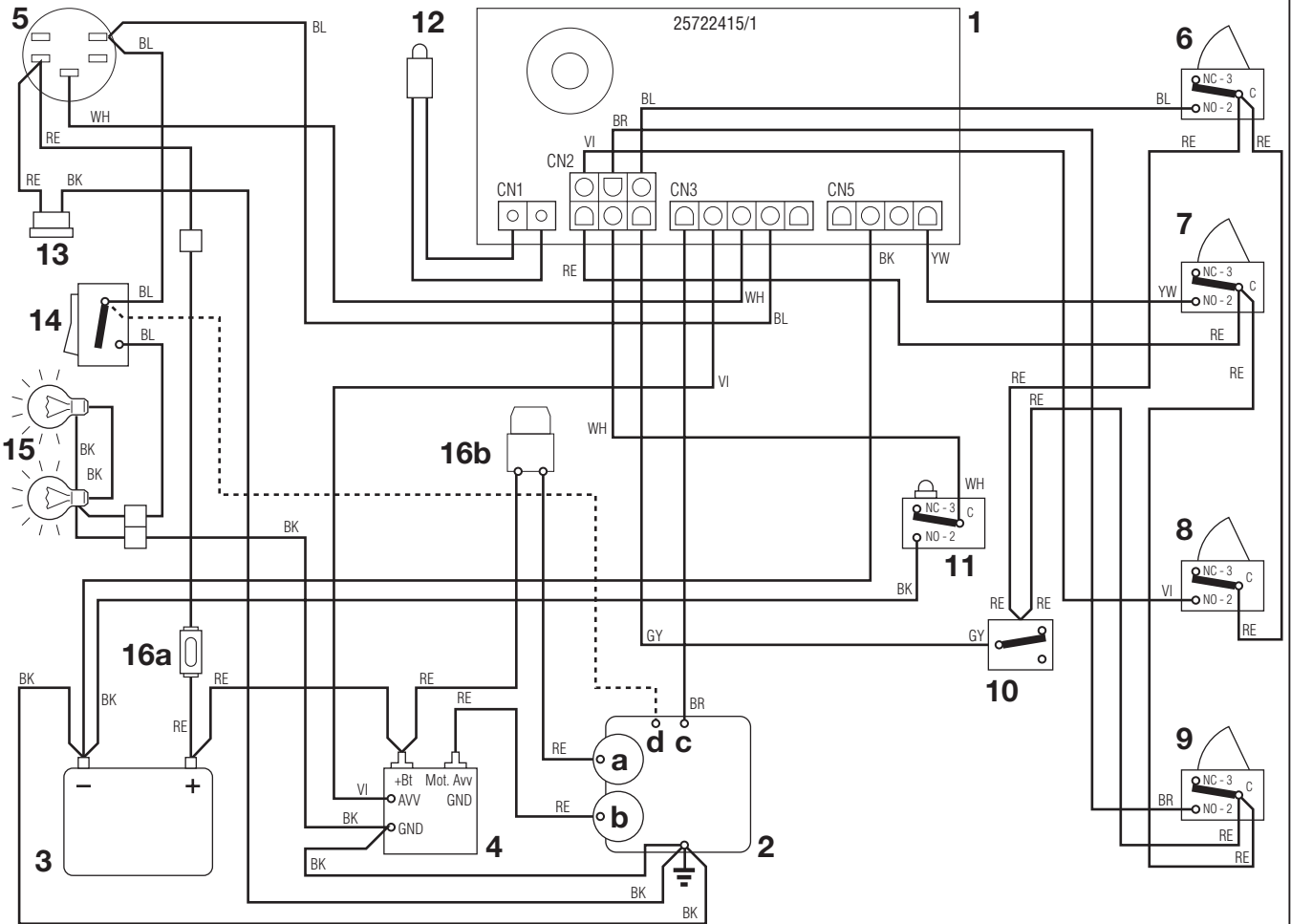

- 1 Electronic card
- 2 Engine
- 2a Generator
- 2b Starter motor
- 2c Engine stop
- 2d Carburattor
- 3 Battery
- 4 Starter relay
- 5 Key ignition switch
- 6 Blades microswitch
- 7 Brake microswitch
- 8 Grasscatcher microswitch
- 9 Seat microswitch
- 10a Neutral microswitch (► Mechanical drive models)
- 10b Neutral microswitch (► Hydrostatic drive models)
- 11 Grasscatcher full microswitch
- 12 Pilot lamp
- 13 Recharge connector
- 14 Headlight switch
- 15 Headlight
- 16a 6.3 A fuse (delayed)
- 16b 25 A fuse

CABLE COLOURS

- BK Black
- BL Blue
- BR Brown
- GY Grey
- OR Orange
- RE Red
- VI Violet
- WH White

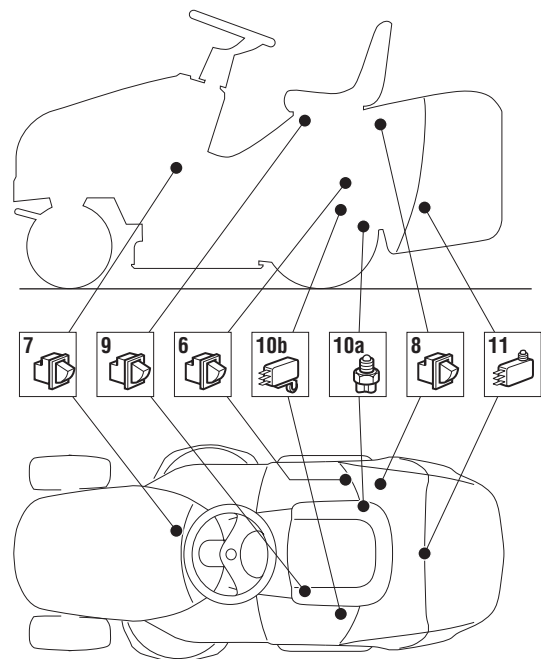

7.11.3 ELECTRICAL DIAGRAMS

from 2006 to

page 2 / 2

2 Engines Honda

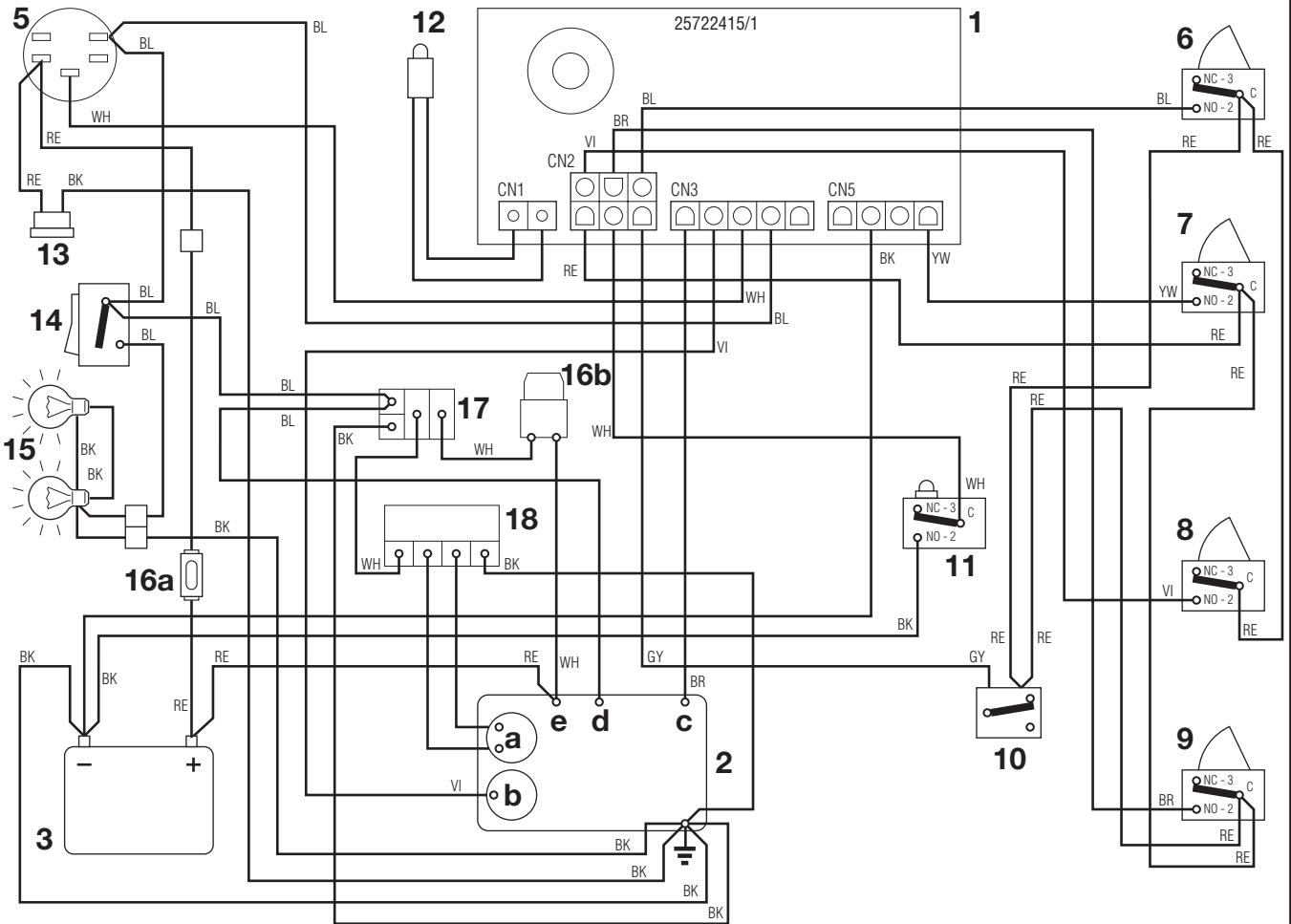

- 1 Electronic card
- 2 Engine
- 2a Generator
- 2b Starter motor
- 2c Engine stop
- 2d Carburattor
- 2e Starter relay
- 3 Battery
- 5 Key ignition switch
- 6 Blades microswitch
- 7 Brake microswitch
- 8 Grasscatcher microswitch
- 9 Seat microswitch
- 10a Neutral microswitch (► Mechanical drive models)
- 10b Neutral microswitch (► Hydrostatic drive models)
- 11 Grasscatcher full microswitch
- 12 Pilot lamp
- 13 Recharge connector
- 14 Headlight switch
- 15 Headlight
- 16a 6.3 A fuse (delayed)
- 16b 25 A fuse
- 17 Recharge relay
- 18 Recharge regulator

CABLE COLOURS

- BK Black
- BL Blue
- BR Brown
- GY Grey
- OR Orange
- RE Red
- VI Violet
- WH White

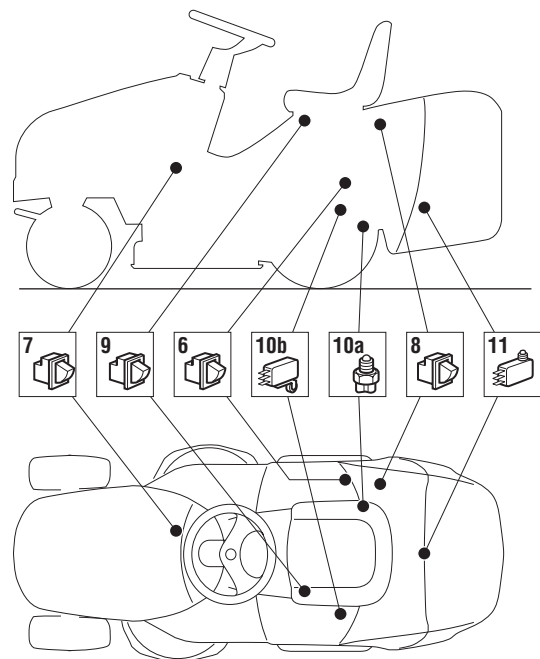

8.1.2 - TIGHTENING TORQUES AND ADJUSTMENTS SUMMARY

from 2007 to

page 1 / 1

8.1 TIGHTENING TORQUES AND ADJUSTMENTS SUMMARY

A) Tightening torques

Below are the specified tightening torques for the fixing bolts on the main parts.

- 1 Screws for engine fastening 25 ÷ 30 Nm
- 2 Screw for engine pulley 45 ÷ 50 Nm
- 3 Rear axle locknut 25 ÷ 30 Nm
- 4 Screws for blades pulleys fastening . 25 ÷ 30 Nm
- 5 Nuts for flange support 25 ÷ 30 Nm
- 6 Screw for blades 45 ÷ 50 Nm

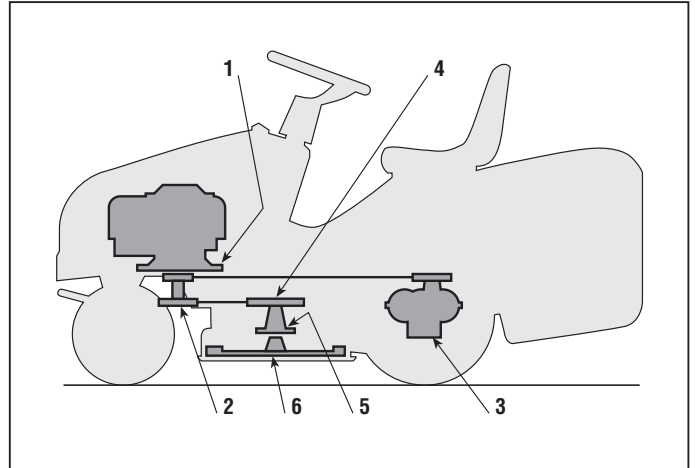

Every section in this manual gives values for all the components involved in each operation.

B) Adjustments

Operation	Position	Position of controls	Adjustment
a) Brake adjustment [see 4.3]			Peerless MST 205-531 E Dana 4360-211 43,5 - 45,5
			Tuff Torq K46S 45-47
b) Drive belt adjustment [see 4.4]			Peerless MST 205-531 E Dana 4360-211 119 - 121
			Tuff Torq K46S 120 - 122
c) Blade engagement adjustment [see 4.1]			97-99

8.2.1 - SUMMARY OF MAIN ASSEMBLY AMOUNTS AND CHECKS

from 2003 to

page 1 / 4

8.2 SUMMARY OF MAIN ASSEMBLY AMOUNTS AND CHECKS

- 1 Frame
- 2 Cutting deck
- 3 Steering geometry
- 4 Drive belt development
- 5 Blades belt development
- 6 Fitting the gearchange control tie-rod (▶ *in mechanical drive models*)
- 7 Fitting the drive control tie-rod (▶ *in mechanical drive models*)
- 8 Fitting the pedal tie-rod (▶ *in hydrostatic drive models*)
- 9 Fitting the deck lifting tie-rod
- 10 Fitting the blades brake tie-rod

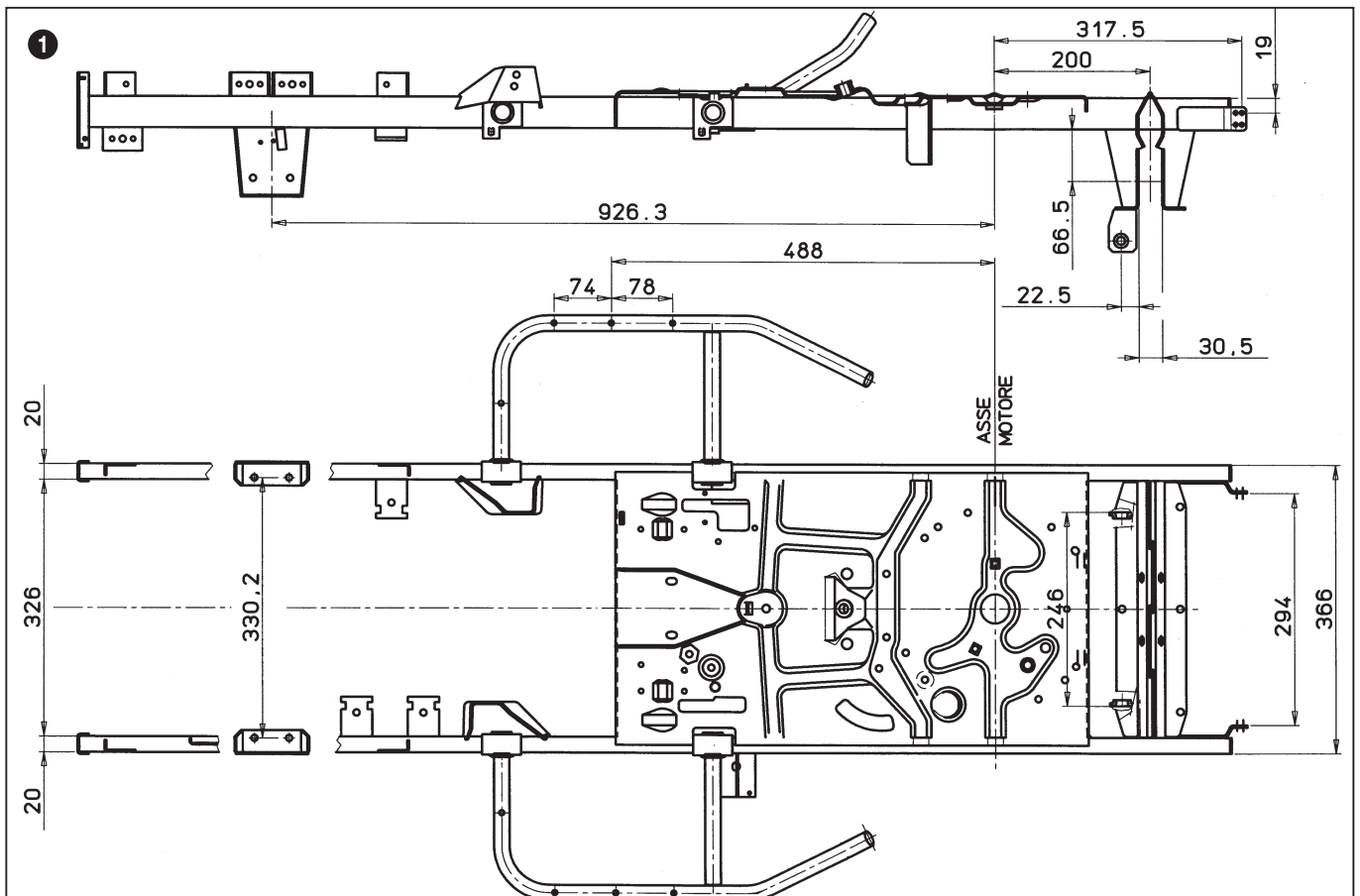

8.2.1 - SUMMARY OF MAIN ASSEMBLY AMOUNTS AND CHECKS

from 2003 to
page 2 / 4

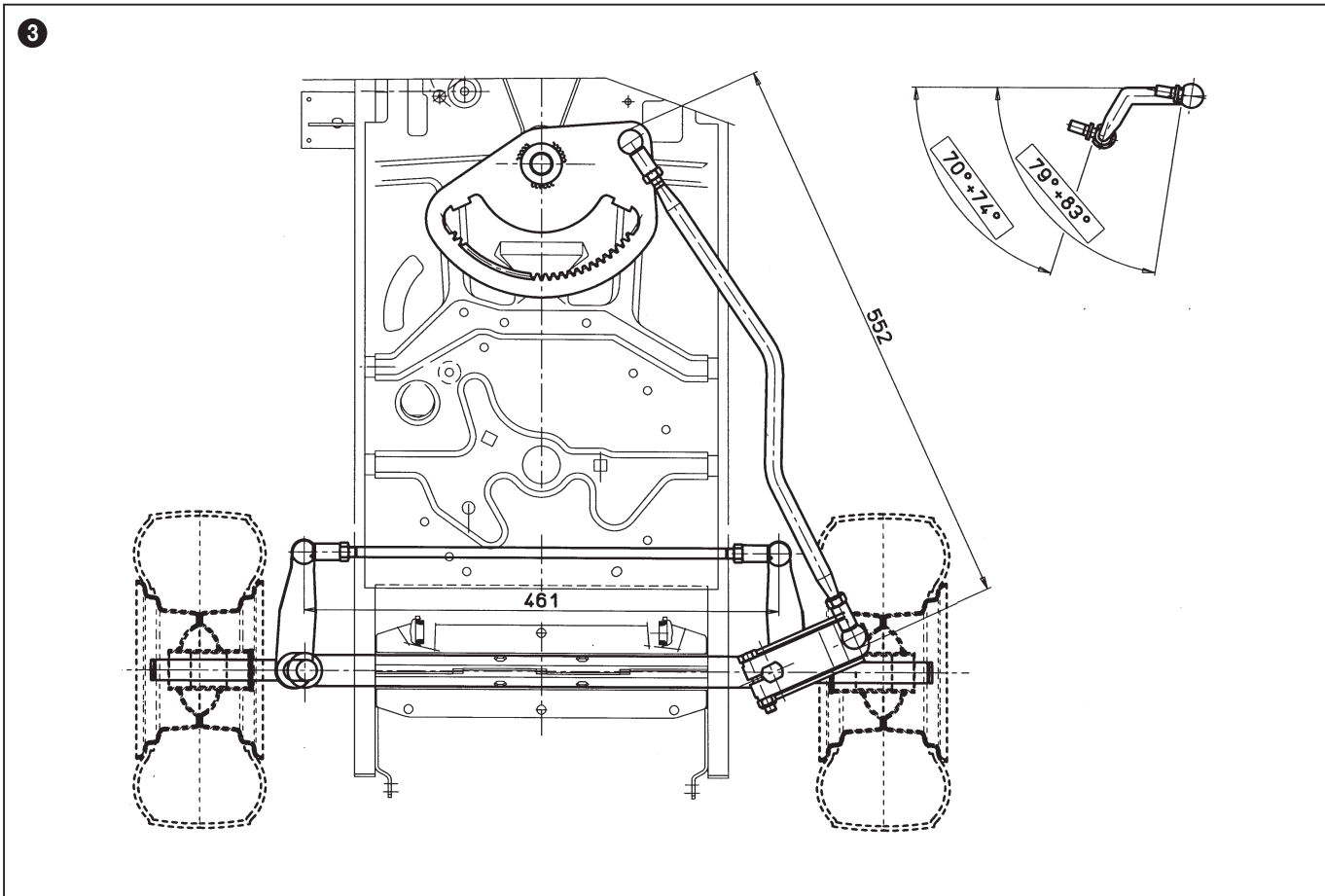
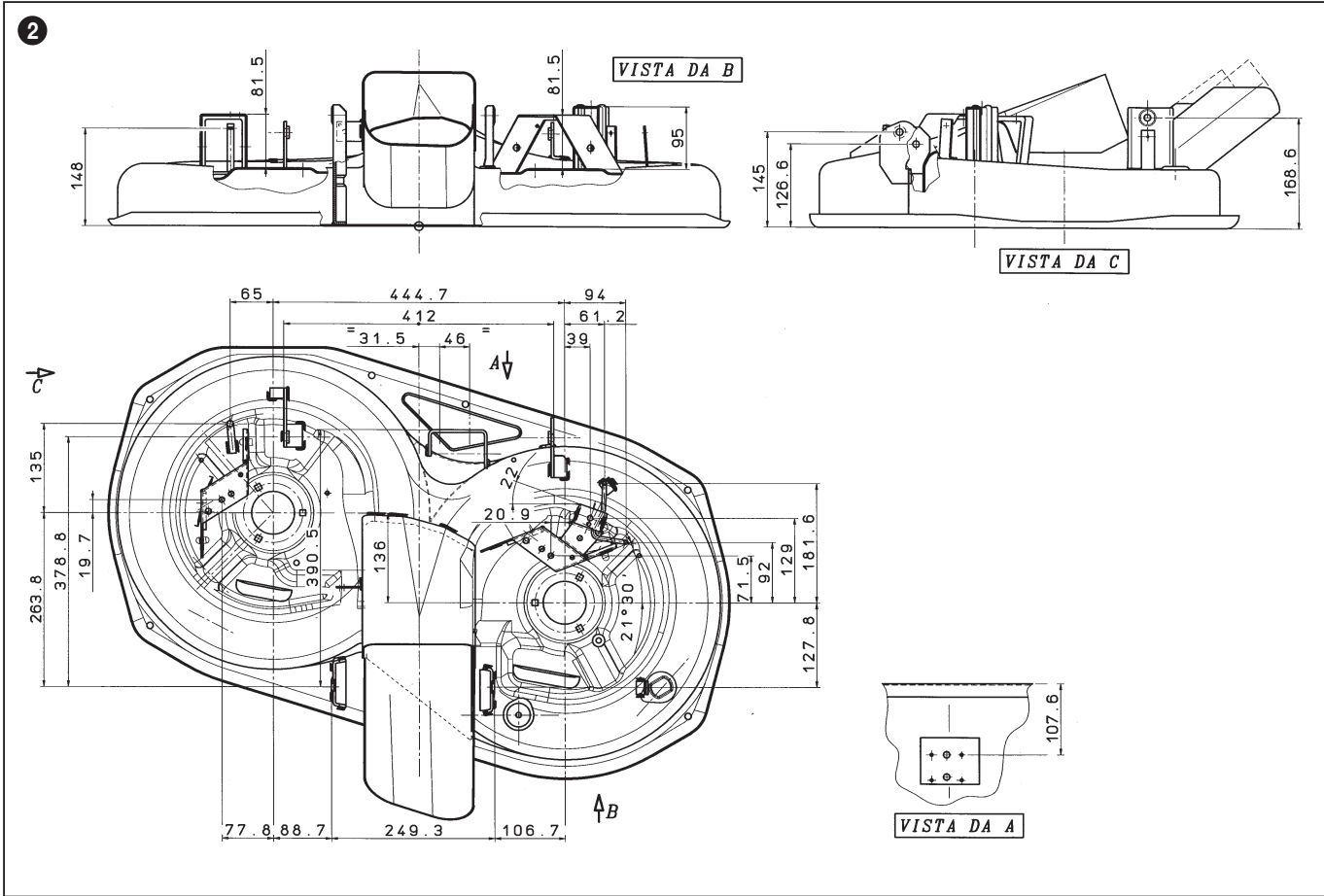

8.2.1 - SUMMARY OF MAIN ASSEMBLY AMOUNTS AND CHECKS

from 2003 to

page ◀ 3 / 4 ▶

4

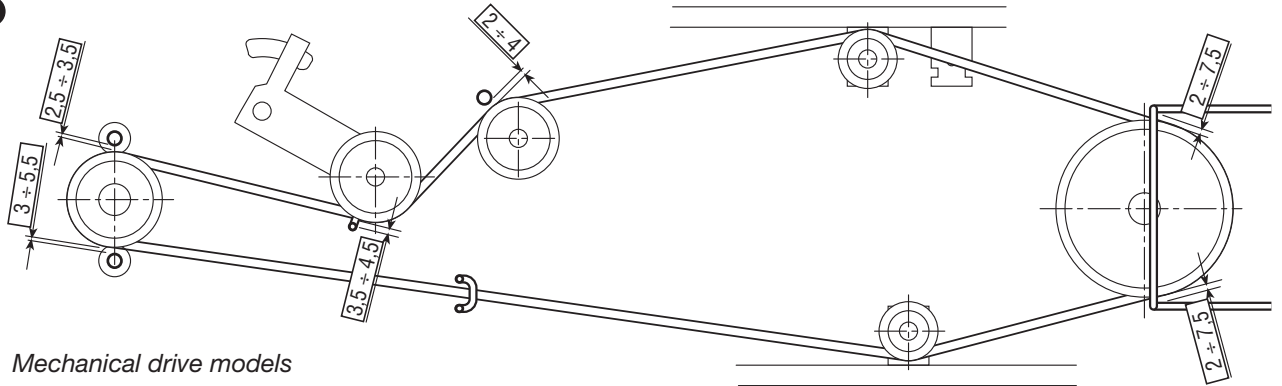

► Mechanical drive models

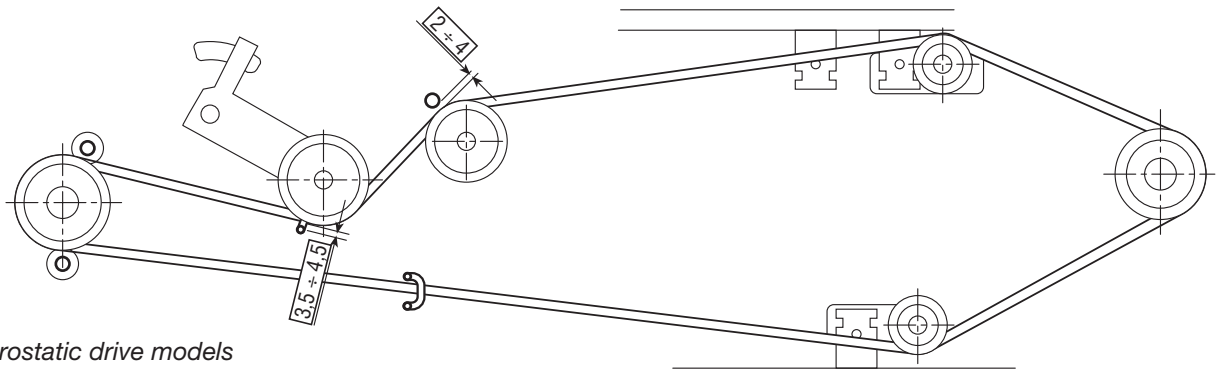

► Hydrostatic drive models

5

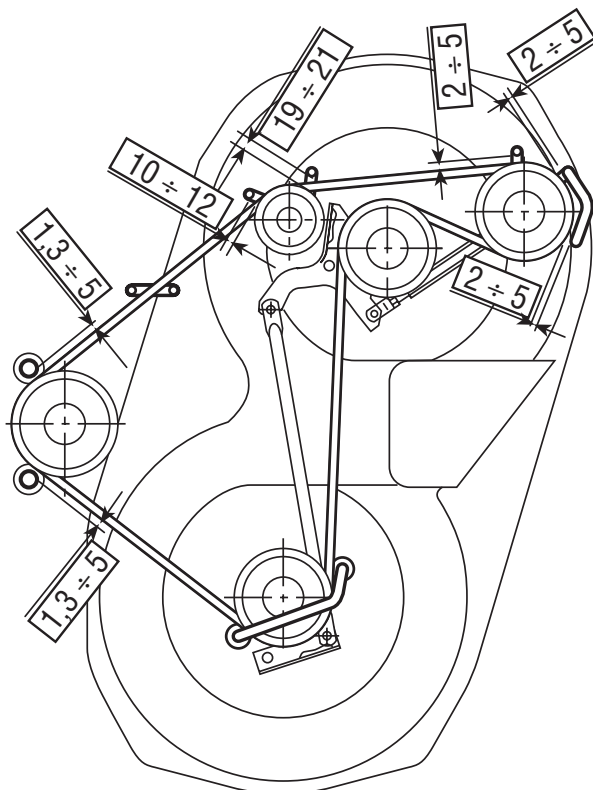

6

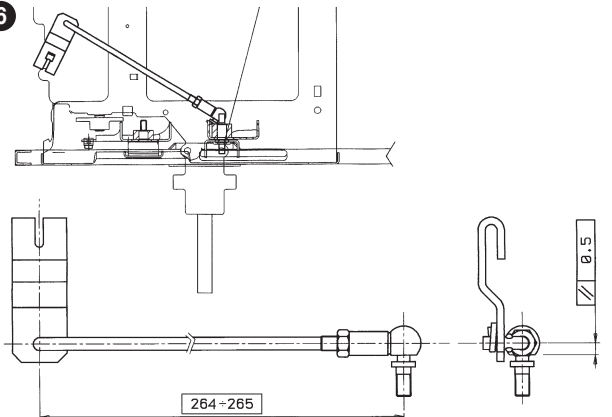

► PEERLESS drive models

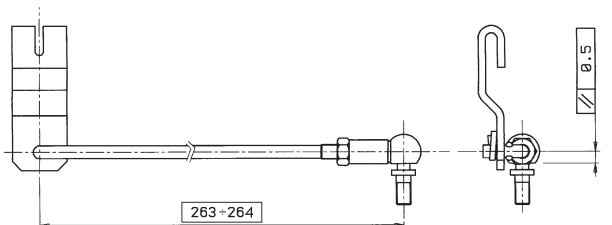

► DANA drive models

8.2.1 - SUMMARY OF MAIN ASSEMBLY AMOUNTS AND CHECKS

from 2003 to

page 4 / 4

