



Green Passion

Illustrated Parts List

**XK Mower Decks 95C-105C
Model Year 2008**

- Use GLOBAL GARDEN PRODUCT Genuine Spare Parts specified in the parts list for repair and/or replacement.
- The contents described in the parts list may change due to improvement.
- The drawings of the spare parts are only indicative and might not represent the part in question exactly.
- The indications "right" - "left" - "front" - "rear" refer to the position of the operator when using the machine.
- When placing orders of parts for repair and/or replacement, make sure that the illustrated parts list is the one applying to the machine's year of manufacture, as shown on the identification plate attached to the machine.

COPYRIGHT by GLOBAL GARDEN PRODUCTS

All rights reserved. No part of this material may be reproduced or transmitted, in any form or by any means, electronic or mechanical, including photocopying, recording or by any information storage and retrieval system, without permission in writing from GLOBAL GARDEN PRODUCTS.

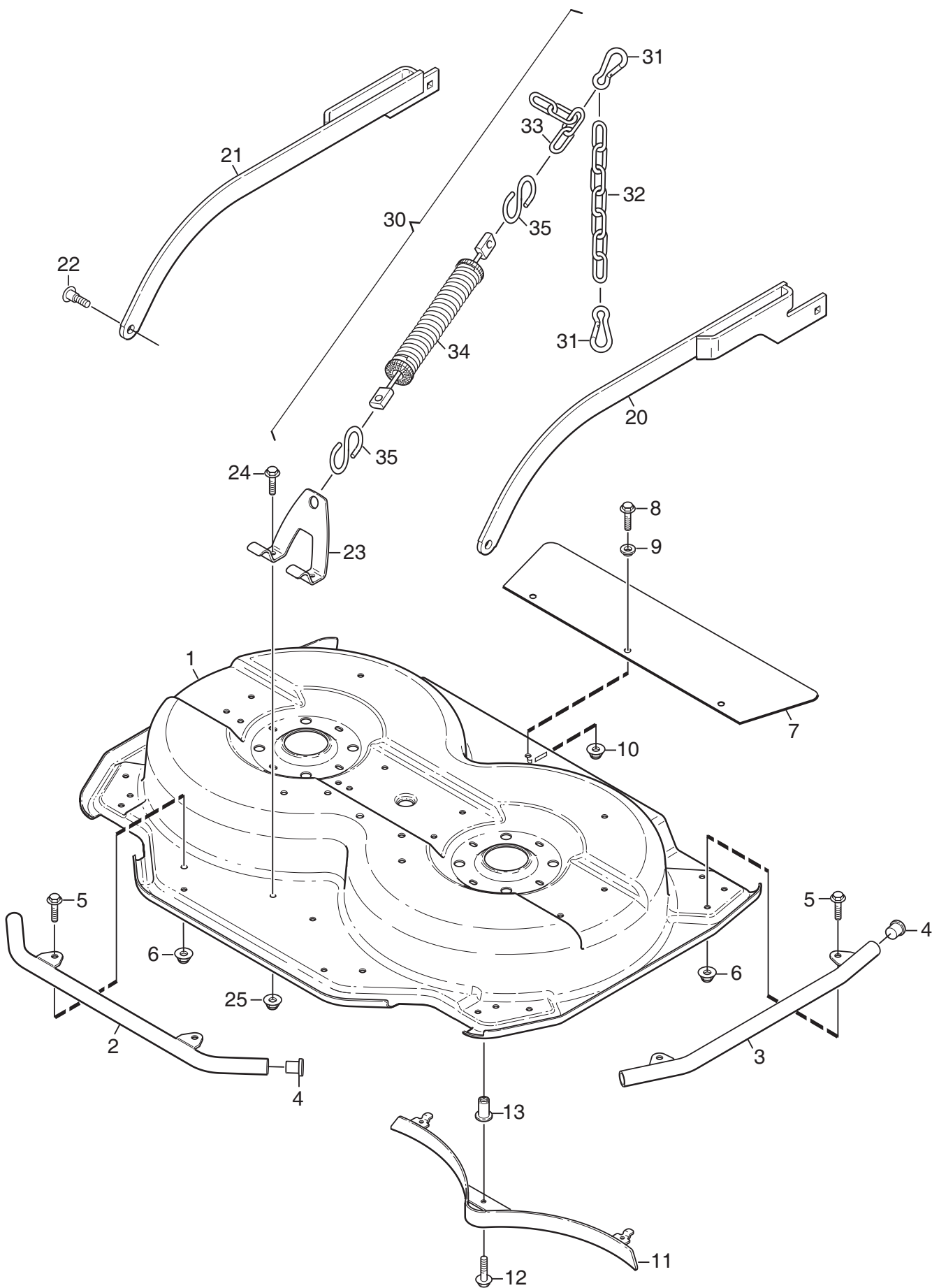

Ausgabe Issue 2008-31		Bild Nr Picture No C137		XK MÄHWERK 95C RAHMEN		XK MOWER DECK 95C FRAME		Seite Page 118		
Pos. Fig.	Anzahl/Quantity				Artikel Nr. Part No	Bezeichnung	Description	Satz Kit	Anmerkung Notes	
	2964									
1	1				1134-6190-03	Haube- rot.....	Casing- red.....		Pos 13 incl.	
2	1				1134-6208-02	Frontschutz- schwarz.....	Front guard tube- bl.			
3	2				1134-6222-02	Seitenschutz- schwarz	Side guard tube- black			
4	6				9403-0025-70	Propfen- schwarz.....	End cap- black.....			
5	6				9959-0816-16	Schraube	Screw			
6	6				9739-0831-22	Mutter	Nut			
7	1				1134-6281-02	Gummischutz	Rubber guard			
8	3				9959-0816-16	Schraube	Screw			
9	3				1134-4185-01	Flanschscheibe	Flange washer			
10	3				9739-0831-22	Mutter	Nut			
11	1				1134-6229-01	Mulchpropfen	Mulching plug			
12	1				9959-0816-16	Schraube	Screw			
13	1				1134-5595-01	• Nietmutter.....	• Riveting nut.....			
20	1				1134-6237-09	Mähwerkarm- L, schw	Deck arm- LH, black.....			
21	1				1134-6237-10	Mähwerkarm- R, schw.....	Deck arm- RH, black			
22	2				1134-6279-01	Schulter-schraube.....	Shoulder bolt			
23	1				1134-6315-02	Hebehalter- schw	Lift bracket- black.....			
24	2				9959-0816-16	Schraube	Screw			
25	2				9739-0831-22	Mutter	Nut			
30	1				1134-6362-01	Hebefeder kpl	Lift spring assy			
31	2				1134-5528-01	• Karabinerhaken.....	• Snap hook.....			
32	1				1134-6368-02	• Kette	• Chain			
33	1				1134-6368-01	• Kette	• Chain			
34	1				1134-6365-03	• Hebefeder	• Lift spring.....			
35	2				1134-4623-01	• S- Haken	• S- hook.....			
99	1				8211-7080-81	Bedienungsanleitung	Owner's manual			
										Pos 31 - 35 incl.
										7 links 4 links
										Not ill.

X

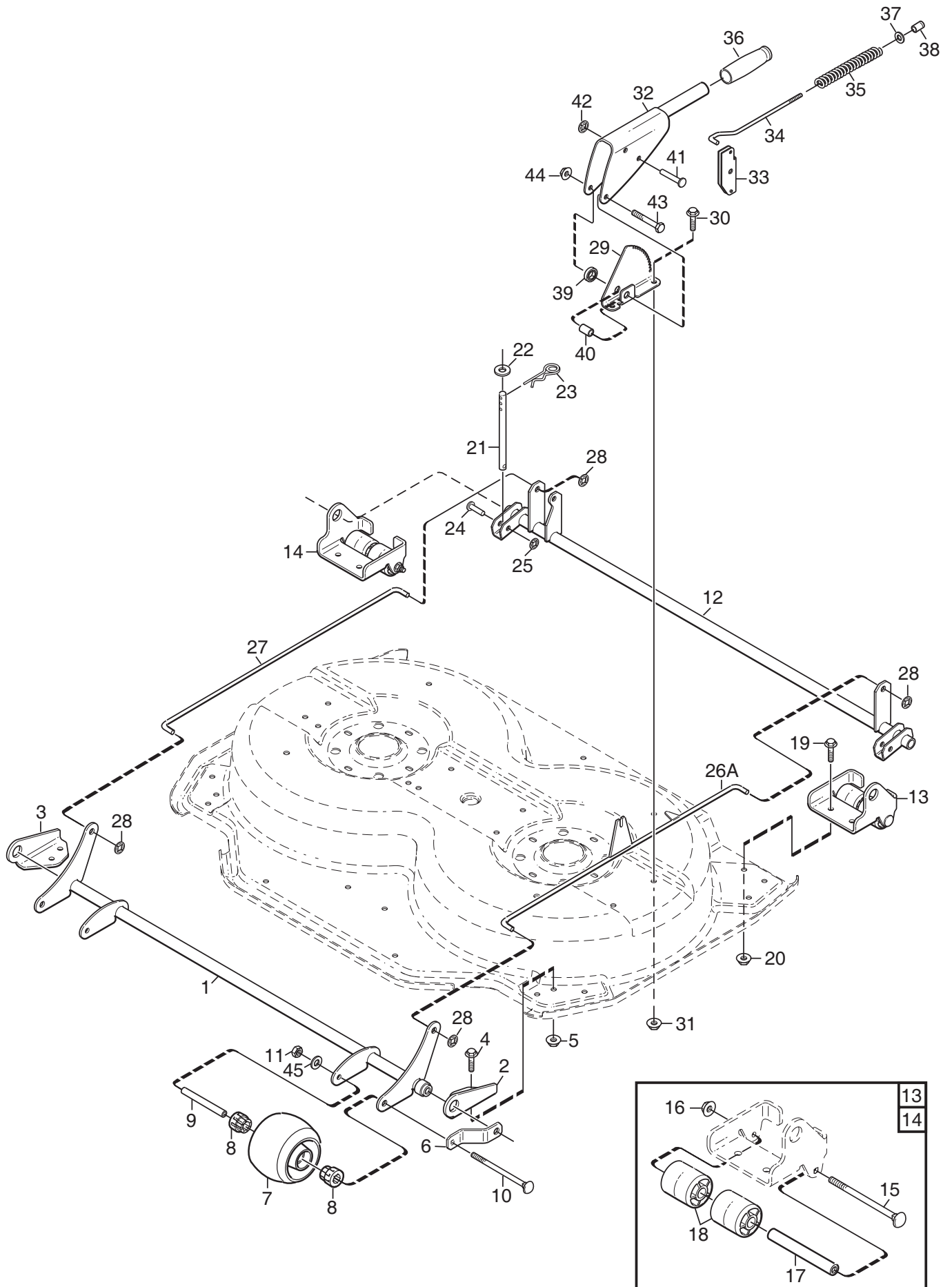

Ausgabe Issue 2008-31		Bild Nr Picture No C127		XK MÄHWERK 95C REGULIERUNGEN		XK MOWER DECK 95C CONTROLS		Seite Page 120	
Pos. Fig.	Anzahl/Quantity				Artikel Nr. Part No	Bezeichnung	Description	Satz Kit	Anmerkung Notes
	2964								
1	1				1134-6275-02	Vorderachse- schwarz	Front axle- black.....		
2	1				1134-6214-03	Halter- L, schwarz.....	Bracket fr- LH, black.....		
3	1				1134-6214-04	Halter- R, schwarz	Bracket fr- RH, black		
4	4				9959-0816-16	Schraube	Screw		
5	4				9739-0831-22	Mutter	Nut		
6	2				1134-6278-02	Leitblech- schwarz.....	Guide- black		
7	2				1134-4284-01	Rad	Wheel.....		
8	4				1134-4319-01	Lager	Bearing.....		
9	2				1134-4318-01	Radachse.....	Wheel axle.....		
10	2				9897-0813-22	Schraube	Screw		
11	2				9747-0831-02	Mutter.....	Lock nut.....		
12	1				1134-6197-02	Hinterachse- schwarz	Rear axle- black		
13	1				1134-6282-01	Rollen- L, m.Halter.....	Roller- LH, w/bracket		Pos 15 - 18 incl.
14	1				1134-6282-02	Rollen- R, m.Halter	Roller- RH, w/bracket.....		Pos 15 - 18 incl.
15	1				9897-0813-02	• Schraube	• Screw		
16	1				9739-0831-22	• Mutter	• Nut		
17	1				1134-4318-01	• Radachse.....	• Wheel axle.....		
18	2				1134-6206-01	• Rollen	• Roller		
19	4				9959-0816-16	Schraube	Screw		
20	4				9739-0831-22	Mutter	Nut		
21	2				1134-6198-01	Stange	Stud		
22	2				9699-0104-02	Scheibe.....	Washer.....		
23	2				9598-2001-02	Schließnadel	Spring pin		
24	2				9646-0098-22	Niet.....	Rivet.....		
25	2				9675-0012-02	Verriegelungsscheibe	Locking washer.....		
26 A	1				1134-6249-02	Druckstange- L	Push rod- LH.....		
27	1				1134-6246-02	Druckstange- R.....	Push rod- RH		
28	4				9675-0015-02	Verriegelungsscheibe	Lock washer.....		
29	1				1134-6255-01	Höhenverstellsektor.....	Height adj. quadrant.....		
30	2				9959-0816-16	Schraube	Screw		
31	2				9739-0831-22	Mutter	Nut		
32	1				1134-6244-02	Höhenverst.hebel- schw	Height adj.lever- bl.		
33	1				1134-6254-01	Sperre.....	Catch.....		
34	1				1134-5444-01	Druckstange	Push rod		
35	1				1134-5445-01	Feder	Spring		
36	1				1134-5503-01	Griff	Handle.....		
37	1				9699-0087-02	Scheibe.....	Flat washer.....		
38	1				1134-3051-01	Sperrknopf.....	Locking knob		
39	1				1134-6286-03	Distanz.....	Spacer.....		
40	1				1134-1565-16	Distanz.....	Spacer.....		
41	2				9646-0105-22	Niet.....	Rivet.....		
42	2				9672-0006-02	Verriegelungsscheibe	Lock washer		
43	1				9997-0850-16	Schraube	Screw		
44	1				9747-0831-02	Mutter.....	Lock nut.....		
45	2				9699-0028-02	Scheibe.....	Flat washer.....		

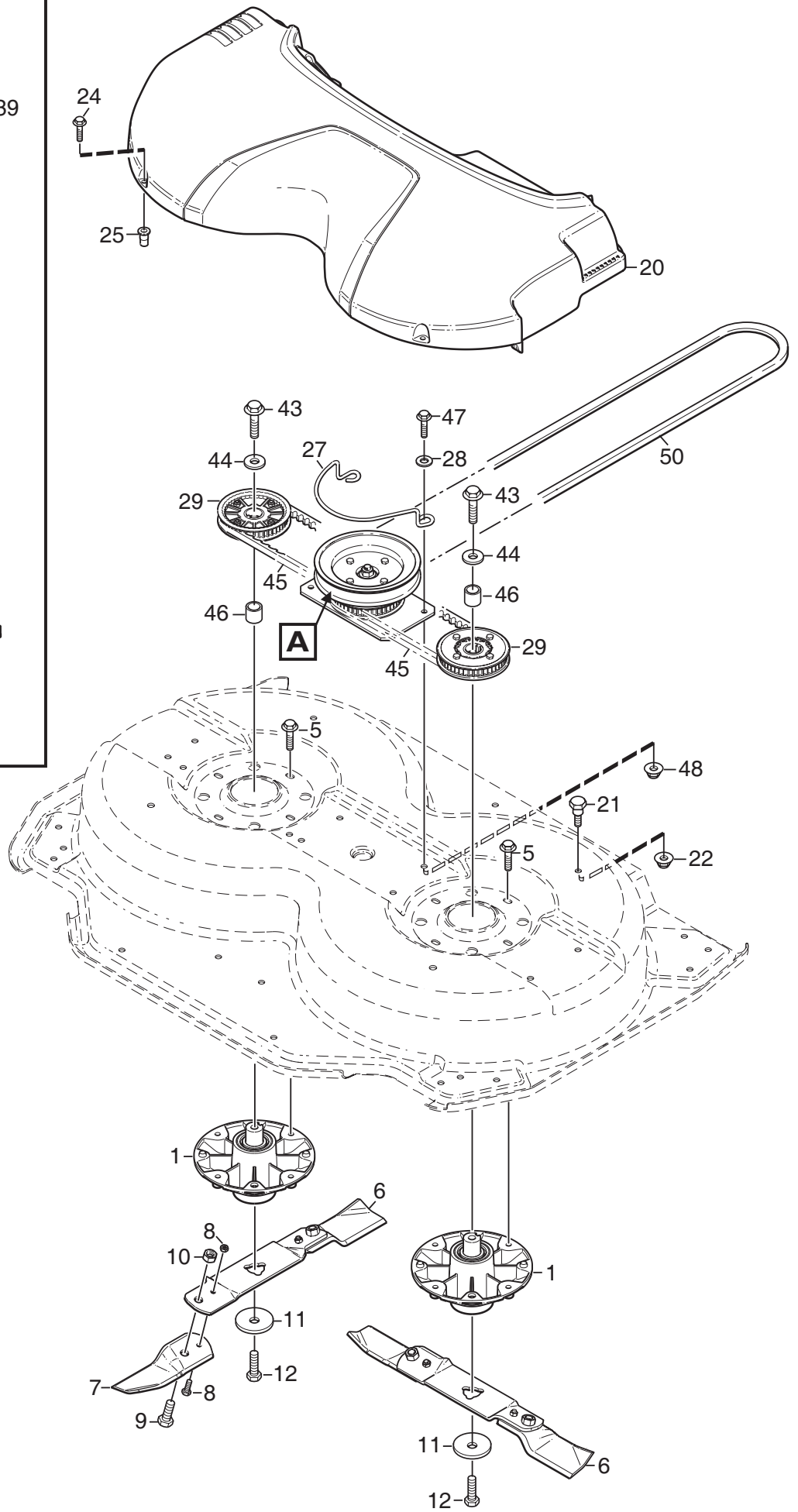
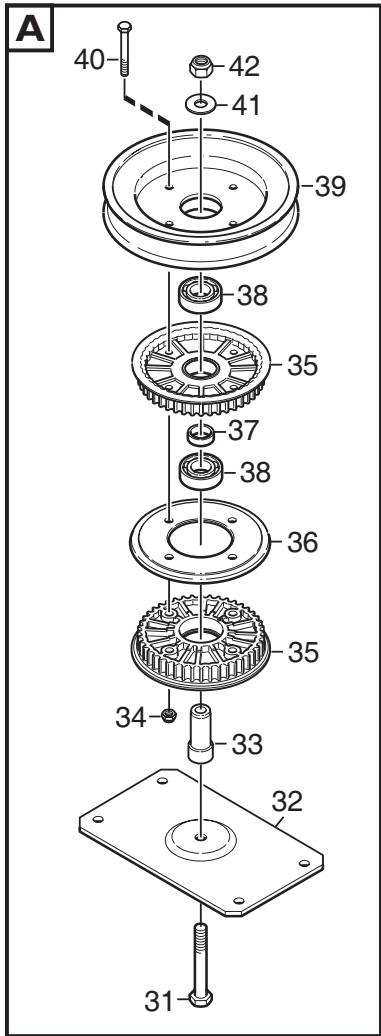

Ausgabe Issue 2008-31		Bild Nr Picture No C129		XK MÄHWERK 95C TRANSMISSION		XK MOWER DECK 95C TRANSMISSION		Seite Page 122	
Pos. Fig.	Anzahl/Quantity			Artikel Nr. Part No	Bezeichnung	Description	Satz Kit	Anmerkung Notes	
	2964 -42 -82	2964 -52 -72							
1	2	2		1134-5831-01	Lagerbuchse kpl	Bearing box assy.....			
5	8	8		9945-0825-16	Schraube	Screw			
6	2	2		1134-6240-02	Messer kpl.....	Blade bar assy.....		Pos 7 incl.	
7	1	1		1134-9119-01	• Messersatz	• Blade kit		Pos 8 - 10 incl.	
8	1	1		1134-9054-01	•• Scherbolzensatz.....	•• Shear bolt kit.....			
9	2	2		1134-6311-01	•• Bolt	•• Bolt.....		7/16" UNF	
10	2	2		1134-6312-01	•• Schloßmutter	•• Lock nut		7/16" UNF	
11	2	2		1134-6211-01	Messerscheibe.....	Blade washer.....			
12	2	2		9997-1060-12	Schraube	Screw.....			
20	1	1		1134-6280-03	Deckel- grau.....	Transm.cover- grey			
21	2	2		1134-0240-01	Schulter-schraube.....	Shoulder screw			
22	2	2		9739-0831-22	Mutter	Nut			
24	2	2		9945-0825-16	Schraube	Screw			
25	2	2		1134-5595-01	Nietmutter	Riveting nut.....			
27	1	1		1134-6431-01	Riemenführung.....	Belt guide			
28	2	2		9699-0090-02	Scheibe.....	Flat washer.....			
29	2	2		1134-6287-01	Zahnriemenscheibe	Toothed belt pulley			
31	1	1		9997-1065-12	Schraube	Screw			
32	1	1		1134-6209-01	Halterung.....	Bracket			
33	1	1		1134-6205-01	Achse.....	Shaft			
34	4	4		9747-0631-02	Mutter	Lock nut			
35	2	2		1134-6186-01	Zahnriemenscheibe	Toothed belt pulley			
36	1	1		1134-6188-01	Distanzplatte.....	Spacer plate			
37	1	1		1134-3725-05	Distanz.....	Spacer.....			
38	2	2		9549-0019-00	Kugellager	Ball bearing			
39	1	1		1134-6203-01	Riemenscheibe	Belt pulley		Ø = 154 mm	
40	4	4		9997-0650-12	Schraube	Screw			
41	1	1		9699-0030-02	Scheibe.....	Flat washer.....			
42	1	1		9747-1031-02	Mutter	Lock nut			
43	2	2		9997-1060-12	Schraube	Screw			
44	2	2		1134-5406-01	Scheibe.....	Washer.....			
45	2	2		9585-0164-01	Zahnriemen	Toothed belt			
46	2	2		1134-5400-04	Distanz.....	Spacer.....			
47	4	4		9959-0820-16	Schraube	Screw			
48	4	4		9739-0831-22	Mutter	Nut			
50	1			9585-0169-01	Keilriemen	V- belt.....			
50		1		9585-0171-01	Keilriemen	V- belt.....			

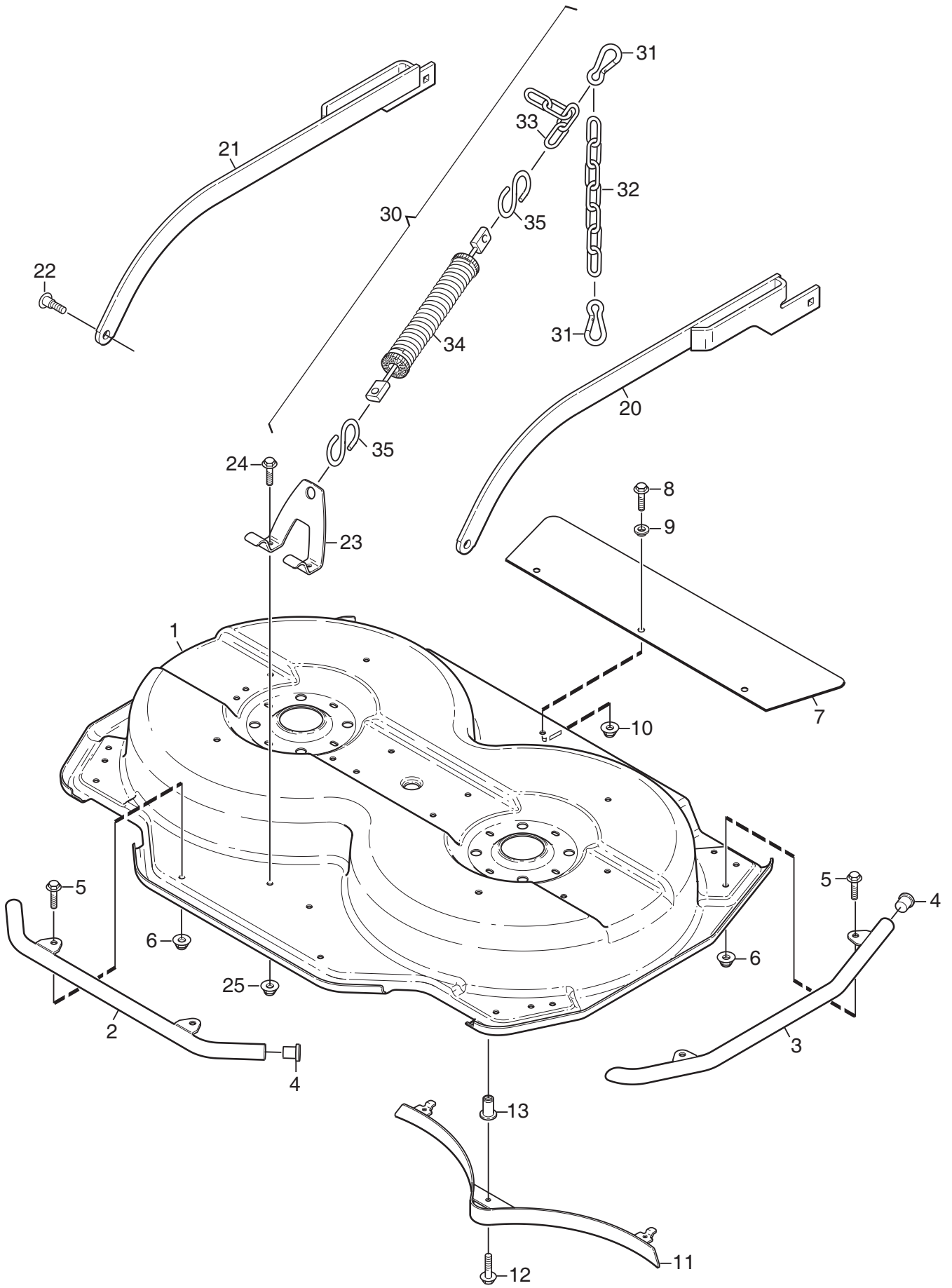

Ausgabe Issue 2008-31		Bild Nr Picture No C130		XK MÄHWERK 105C RAHMEN		XK MOWER DECK 105C FRAME		Seite Page 124		
Pos. Fig.	Anzahl/Quantity				Artikel Nr. Part No	Bezeichnung	Description	Satz Kit	Anmerkung Notes	
	2972									
1	1				1134-6191-03	Haube- rot.....	Casing- red.....		Pos 13 incl.	
2	1				1134-6208-02	Frontschutz- schwarz.....	Front guard tube- bl.			
3	2				1134-6223-02	Seitenschutz- schwarz	Side guard tube- black			
4	4				9403-0025-70	Propfen- schwarz.....	End cap- black.....			
5	6				9959-0816-16	Schraube	Screw			
6	6				9739-0831-22	Mutter	Nut			
7	1				1134-6281-03	Gummischutz	Rubber guard			
8	3				9959-0816-16	Schraube	Screw			
9	3				1134-4185-01	Flanschscheibe	Flange washer			
10	3				9739-0831-22	Mutter	Nut			
11	1				1134-6231-01	Mulchpropfen	Mulching plug			
12	1				9959-0816-16	Schraube	Screw			
13	1				1134-5595-01	• Nietmutter.....	• Riveting nut.....			
20	1				1134-6237-07	Mähwerkarm- L, schw	Deck arm- LH, black.....			
21	1				1134-6237-08	Mähwerkarm- R, schw.....	Deck arm- RH, black			
22	2				1134-6279-01	Schulter-schraube.....	Shoulder bolt			
23	1				1134-6315-02	Hebehalter- schw	Lift bracket- black.....			
24	2				9959-0816-16	Schraube	Screw			
25	2				9739-0831-22	Mutter	Nut			
30	1				1134-6362-01	Hebefeder kpl	Lift spring assy			
31	2				1134-5528-01	• Karabinerhaken.....	• Snap hook.....			
32	1				1134-6368-02	• Kette	• Chain			
33	1				1134-6368-01	• Kette	• Chain			
34	1				1134-6365-03	• Hebefeder	• Lift spring.....			
35	2				1134-4623-01	• S- Haken	• S- hook.....			
99	1				8211-7080-81	Bedienungsanleitung	Owner's manual			
										Pos 31 - 35 incl.
										7 links 4 links
										Not ill.

X

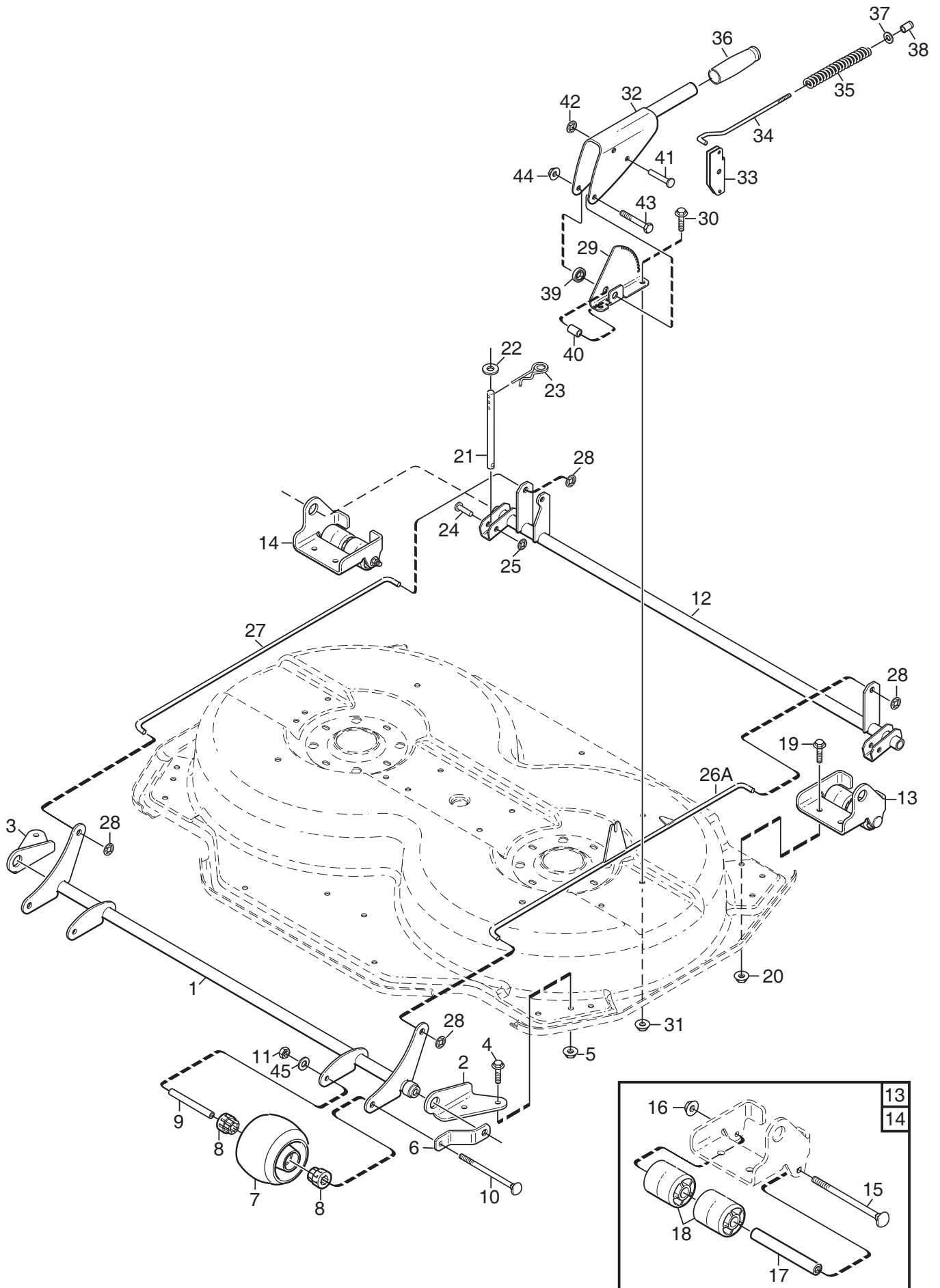

Ausgabe Issue 2008-31		Bild Nr Picture No C131		XK MÄHWERK 105C REGULIERUNGEN		XK MOWER DECK 105C CONTROLS		Seite Page 126	
Pos. Fig.	Anzahl/Quantity				Artikel Nr. Part No	Bezeichnung	Description	Satz Kit	Anmerkung Notes
	2972								
1	1				1134-6275-02	Vorderachse- schwarz	Front axle- black.....		
2	1				1134-6215-03	Halter- L, schwarz.....	Bracket fr- LH, black.....		
3	1				1134-6215-04	Halter- R, schwarz	Bracket fr- RH, black		
4	4				9959-0816-16	Schraube	Screw.....		
5	4				9739-0831-22	Mutter	Nut		
6	2				1134-6278-02	Leitblech- schwarz.....	Guide- black		
7	2				1134-4284-01	Rad	Wheel.....		
8	4				1134-4319-01	Lager	Bearing.....		
9	2				1134-4318-01	Radachse.....	Wheel axle.....		
10	2				9897-0813-02	Schraube	Screw.....		
11	2				9747-0831-02	Mutter.....	Lock nut.....		
12	1				1134-6197-02	Hinterachse- schwarz	Rear axle- black.....		
13	1				1134-6282-01	Rollen- L, m.Halter.....	Roller- LH, w/bracket		Pos 15 - 18 incl.
14	1				1134-6282-02	Rollen- R, m.Halter	Roller- RH, w/bracket.....		Pos 15 - 18 incl.
15	1				9897-0813-02	• Schraube	• Screw		
16	1				9739-0831-22	• Mutter	• Nut		
17	1				1134-4318-01	• Radachse.....	• Wheel axle.....		
18	2				1134-6206-01	• Rollen	• Roller		
19	4				9959-0816-16	Schraube	Screw.....		
20	4				9739-0831-22	Mutter	Nut		
21	2				1134-6198-01	Stange	Stud		
22	2				9699-0104-02	Scheibe.....	Washer.....		
23	2				9598-2001-02	Schließnadel	Spring pin		
24	2				9646-0098-22	Niet.....	Rivet.....		
25	2				9675-0012-02	Verriegelungsscheibe	Locking washer.....		
26 A	1				1134-6249-01	Druckstange- L	Push rod- LH.....		
27	1				1134-6246-01	Druckstange- R.....	Push rod- RH		
28	4				9675-0015-02	Verriegelungsscheibe	Lock washer.....		
29	1				1134-6255-01	Höhenverstellsektor.....	Height adj. quadrant.....		
30	2				9959-0816-16	Schraube	Screw.....		
31	2				9739-0831-22	Mutter	Nut		
32	1				1134-6244-02	Höhenverst.hebel- schw	Height adj.lever- bl.		
33	1				1134-6254-01	Sperre.....	Catch.....		
34	1				1134-5444-01	Druckstange	Push rod		
35	1				1134-5445-01	Feder	Spring		
36	1				1134-5503-01	Griff	Handle.....		
37	1				9699-0087-02	Scheibe.....	Flat washer.....		
38	1				1134-3051-01	Sperrknopf.....	Locking knob		
39	1				1134-6286-03	Distanz.....	Spacer.....		
40	1				1134-1565-16	Distanz.....	Spacer.....		
41	2				9646-0105-22	Niet.....	Rivet.....		
42	2				9672-0006-02	Verriegelungsscheibe	Lock washer		
43	1				9997-0850-16	Schraube	Screw.....		
44	1				9747-0831-02	Mutter.....	Lock nut.....		
45	2				9699-0028-02	Scheibe.....	Flat washer.....		

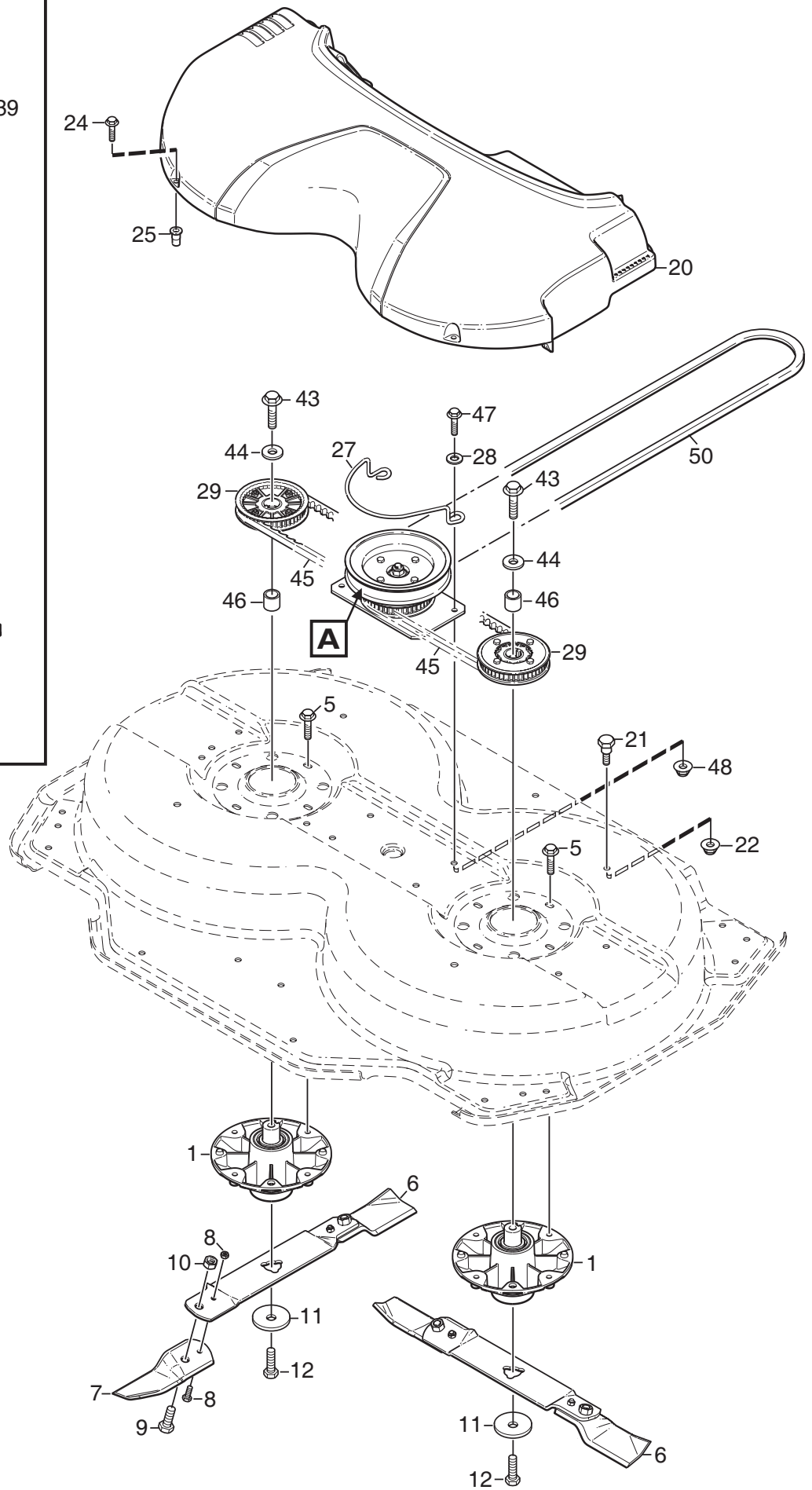
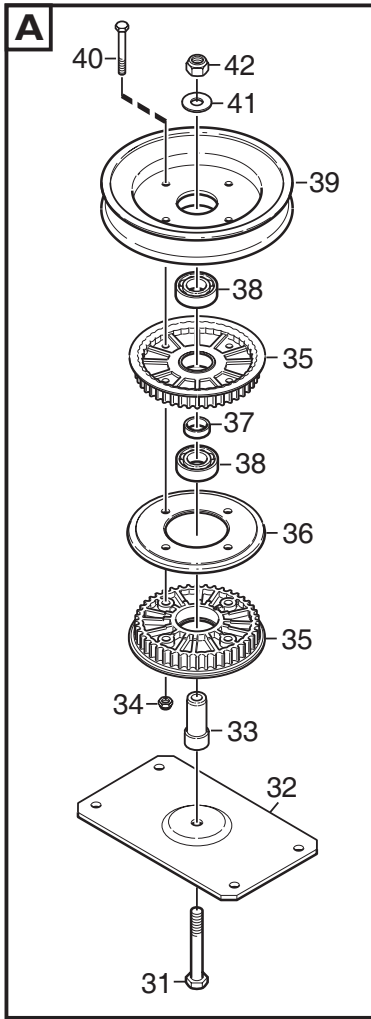

Ausgabe Issue 2008-31		Bild Nr Picture No C132		XK MÄHWERK 105C TRANSMISSION		XK MOWER DECK 105C TRANSMISSION		Seite Page 128	
Pos. Fig.	Anzahl/Quantity			Artikel Nr. Part No	Bezeichnung	Description	Satz Kit	Anmerkung Notes	
	2972 -42 -82	2972 -52 -72							
1	2	2		1134-5831-01	Lagerbuchse kpl	Bearing box assy.....			
5	8	8		9945-0825-16	Schraube	Screw			
6	2	2		1134-6240-03	Messer kpl.....	Blade bar assy.....		Pos 7 incl.	
7	1	1		1134-9119-01	• Messersatz	• Blade kit		Pos 8 - 10 incl.	
8	1	1		1134-9054-01	•• Scherbolzensatz.....	•• Shear bolt kit.....			
9	2	2		1134-6311-01	•• Bolt	•• Bolt.....		7/16" UNF	
10	2	2		1134-6312-01	•• Schloßmutter	•• Lock nut		7/16" UNF	
11	2	2		1134-6211-01	Messerscheibe.....	Blade washer.....			
12	2	2		9997-1060-12	Schraube	Screw.....			
20	1	1		1134-6280-03	Deckel- grau.....	Transm.cover- grey			
21	2	2		1134-0240-01	Schulter-schraube.....	Shoulder screw			
22	2	2		9739-0831-22	Mutter	Nut			
24	2	2		9945-0825-16	Schraube	Screw			
25	2	2		1134-5595-01	Nietmutter	Riveting nut.....			
27	1	1		1134-6431-01	Riemenführung.....	Belt guide			
28	2	2		9699-0090-02	Scheibe.....	Flat washer.....			
29	2	2		1134-6287-01	Zahnriemenscheibe	Toothed belt pulley			
31	1	1		9997-1065-12	Schraube	Screw			
32	1	1		1134-6209-01	Halterung.....	Bracket			
33	1	1		1134-6205-01	Achse.....	Shaft			
34	4	4		9747-0631-02	Mutter	Lock nut			
35	2	2		1134-6186-01	Zahnriemenscheibe	Toothed belt pulley			
36	1	1		1134-6188-01	Distanzplatte.....	Spacer plate			
37	1	1		1134-3725-05	Distanz.....	Spacer.....			
38	2	2		9549-0019-00	Kugellager	Ball bearing			
39	1	1		1134-6204-01	Riemenscheibe	Belt pulley		Ø = 168 mm	
40	4	4		9997-0650-12	Schraube	Screw			
41	1	1		9699-0030-02	Scheibe.....	Flat washer.....			
42	1	1		9747-1031-02	Mutter	Lock nut			
43	2	2		9997-1060-12	Schraube	Screw			
44	2	2		1134-5406-01	Scheibe.....	Washer.....			
45	2	2		9585-0165-01	Zahnriemen	Toothed belt			
46	2	2		1134-5400-04	Distanz.....	Spacer.....			
47	4	4		9959-0820-16	Schraube	Screw			
48	4	4		9739-0831-22	Mutter	Nut			
50	1			9585-0170-01	Keilriemen	V- belt.....			
50		1		9585-0172-01	Keilriemen	V- belt.....			