

SV200  
SV200ES

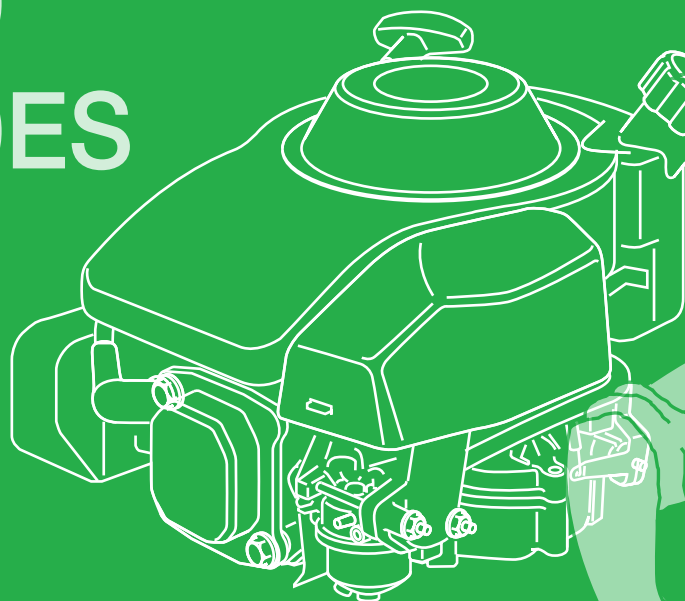

R200  
R200ES

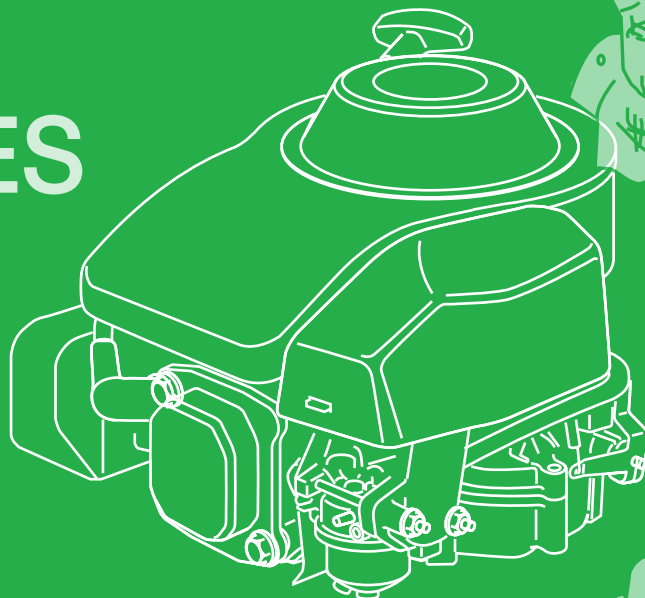

Workshop manual

2007

***SV200 • SV200ES***  
***R200 • R200ES***

# **SERVICE MANUAL**

**Rel. 2.0 - 4/2007**

The manufacturer reserves the right to make all the necessary technical or commercial improvements to its products, so there may be some differences between the series of engines and the contents of this manual. However the basic specifications and different operating procedures will remain the same.

© by GLOBAL GARDEN PRODUCTS No use of the illustrations or duplication, reproduction or translation, even partial, of the texts in this document may be made without explicit authorization.

<b>i.1</b> <b>INDEX</b>	▶ ▶	from 2007 to page 1 / 1
----------------------------	--------	----------------------------

## MAIN CHAPTERS

### 1. Rules and procedures for Service Centres

*This chapter covers all the main aspects of the relationship between the manufacturer and the service centres.*

*A close collaboration between the manufacturer and the service centres is conclusive for solving problems in the most effective way as well as maintaining an image of efficiency and reliability. Compliance with these brief and simple guidelines will facilitate this task and prevent general misunderstandings and time-wasting for both the manufacturer and the service centre.*

### 2. General and safety regulations

*This chapter covers the main aspects of a servicing procedure and the general rules for guaranteeing a successful service which protects the environment and respects the safety of both the serviceman and the user of the apparatus.*

### 3. Technical data and specifications

*This chapter summarizes all the technical information regarding the engine, adjustment data,*

*tightening torques, expendable materials and spare parts available.*

### 4. Engine tuning

*This chapter describes how to plan a maintenance program and outlines a servicing procedure for general engine tuning.*

### 5. Troubleshooting

*This chapter summarizes all the main operating faults and indicates probable causes and procedures for solving them.*

### 6. Servicing procedures

*This chapter describes the servicing procedures for dealing with the most frequent operating faults.*

*The descriptions follow a logical sequence and may cover operations not strictly linked to the one described.*

*In this case, you should read the entire procedure carefully so that you can leave out any irrelevant operations without missing necessary steps.*

## CONTENTS

ii	1	Introduction
1.1	0	Rules and procedures for Service Centres
2.1	0	General and safety regulations
3.1	1	Technical data and specifications
4.1	0	Testing and tuning the engine
5.1	1	Troubleshooting
6.1	1	Tank and supply
6.2	1	Starting system
6.3	1	Intake system
6.4	1	Carburation
6.5	1	Carburettor governor system
6.6	1	Ignition system
6.7	1	Turning off and stopping the engine
6.8	1	Exhaust system
6.9	1	Engine block (External operations)
6.10	1	Engine block (Overhauling internal parts)
6.11	0	Electrical starting system and recharge alternator

<p>ii.1 <b>INTRODUCTION</b></p>	<p>from 2007 to page 1 / 1</p>
-------------------------------------	------------------------------------

## INTRODUCTION

The purpose of this manual is to help Service Centres service, disassemble and repair SV200 engines.

Each page of this manual states the following information:

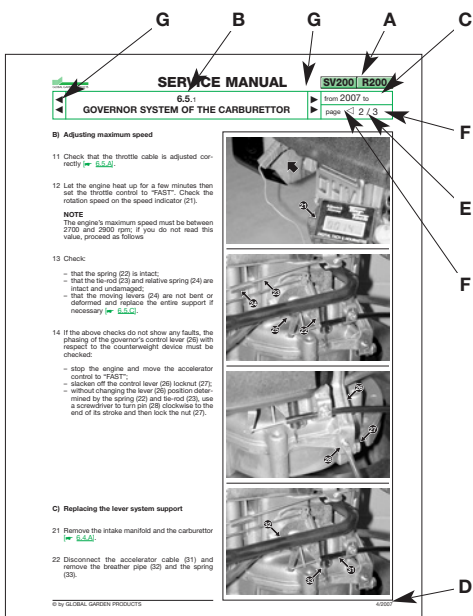

- A)** Engine type or types the page is referring to.
- B)** Page number, specifically:
  - the first two figures separated by a point indicate the section and the chapter;
  - the third figure indicates the modification index.
- C)** Temporary validity of the page, with reference to the year of manufacture [➡ 3.1.A] or serial numbers.
- D)** Date of release.
- E)** Page number and total number of pages dedicated to the subject.
- F)** Any previous or ensuing pages dedicated to the subject.
- G)** Any chapters before or after the current one.

The manual refers to the following symbols:

**⚠** Warns of operations that should be carried out with utmost care to avoid impairing the functionality and safety of the lawnmower.

**⚠** Warns of operations that should be carried out with utmost care to avoid injury to the operator.

**➡** Reference to another procedure or part of the manual.

**➤** Shows all the operations requiring different intervention methods depending on the engine version.

**NOTE**  
All references to “right”, “left”, “front”, “rear”, “upper” and “lower” refer to the engine installed on the lawnmower and viewed from the user’s operating position.

The manual has left out the simplest and quickest operations that can be handled by a good mechanic, while concentrating more on specific aspects and the best servicing procedures.

Please read all the contents of this manual to become familiar with the basics of the engine, which is fundamental for operating in a logical manner without making errors or wasting time.

All problems related to use are fully covered in the user manual.

1.1.0	from 2005 to
<b>RULES AND PROCEDURES FOR SERVICE CENTRES</b>	page 1 / 1

## 1.1 RULES AND PROCEDURES FOR SERVICE CENTRES

### A) Guarantee validity

The warranty is supplied under the terms, procedures and limits stated in the contract.

### B) Service repairs after guarantee period

The Service Centre must write a report for each intervention containing the serial number of the engine [[↔ 3.1.A](#)], and summary information about the problems complained of, the intervention made and possible spare parts used.

A copy of these reports must be kept and made available to the manufacturer together with the replaced parts, in case clients should make further complaints.

### C) Fault notification

The manufacturer should be informed of all faults that recur frequently; this allows it to carefully examine the problem and make corrections on the production line.

Similarly, the manufacturer shall report any faults traced on its engines, indicating the best troubleshooting procedure.

### D) Spare parts request

When asking for spare parts, you must quote their code by referring to the exploded views corresponding to the year of manufacture reported on the nameplate [[↔ 3.1.A](#)].

2.1.0	from 2005 to
<b>GENERAL AND SAFETY REGULATIONS</b>	page 1 / 1

## 2.1 GENERAL AND SAFETY REGULATIONS

### A) Qualification of operators

All maintenance, disassembly and repairs must be carried out by expert mechanics who are familiar with all the accident prevention and safety regulations after reading through the procedures in this manual.

### B) Safety measures

All the engines are built in conformity with the European safety regulations in force.

To maintain initial safety levels in the long term, the Service Centre should take proactive measures by making checks whenever possible.

Every time you are asked to service the engine (or the lawnmower on which it is installed), you should:

#### 1) check:

- that the safety devices function correctly;
- that the casings and protection covers have not been removed;
- that the nameplates or specification labels have not been removed or made illegible, (as they form an integral part of the safety devices).

#### 2) also:

- restore to proper working order any safety devices which have been manipulated or removed;
- replace ineffective, damaged or missing guards and covers;
- replace illegible labels;
- do not carry out operations or modifications on the lawnmower or on the engine that could affect their performance or lead to an improper or different use from the one for which it has been designed and approved;
- warn the customer that the failure to comply with the above points automatically voids the warranty and the responsibility of the manufacturer.

### C) Precautions during servicing

The operations described in this manual do not entail particularly dangerous situations besides the normal hazard related to mechanical operations and that can be avoided by taking the necessary care and attention normally required for this type of work.

As well as following the usual accident prevention regulations that apply to most repair shops, we recommend you:

- disconnect the spark plug cap before servicing;
- protect hands with suitable working gloves, especially when working near the cutting unit;
- check that you do not cause accidental petrol leaks or other losses;
- do not smoke when working on the tank or when handling petrol;
- do not inhale oil or petrol fumes;
- clean up all traces of spilt petrol immediately;
- test the engine in a well-ventilated environment or where there are adequate exhaust fume extraction systems;
- do not pollute the environment with oil, petrol or other waste and dispose of all waste in accordance with the laws in force.

### D) Necessary equipment

All the operations can be carried out with the tools normally used in a good garage.

Some operations require special equipment and tools [ 3.1.F].

### E) Symbols and terms used for safety purposes

Some paragraphs in this manual are preceded by symbols which indicate the following:



Operations that should be carried out with utmost care to avoid impairing the functionality and safety of the engine and/or lawnmower on which it is installed.



Operations that should be carried out with utmost care to avoid injury to operators.

**“WARNING”** stresses the risk of injury to oneself and others if instructions and regulations are not observed.



<p>4.1.0 <b>ENGINE TUNING AND TESTING</b></p>	<p>from 2005 to page 1 / 1</p>
---	------------------------------------

## 4.1 ENGINE TUNING AND TESTING

### A) Operating guidelines

The Instruction Manual describes a series of operations for the client (shown in the following table) to ensure minimum basic maintenance.

Operation	First 5 hours	Every 5 hours or daily	Every 25 hours or every season	Every 50 hours or every season	Every 100 hours
Check oil level	-	✓	-	-	-
Change oil <sup>1)</sup>	✓	-	-	✓	-
Clean muffler and engine	-	-	✓	-	-
Check air cleaner <sup>2)</sup>	-	-	✓	-	-
Oil air cleaner <sup>2)</sup>	-	-	✓	-	-
Check spark plug	-	-	✓	-	-
Replace spark plug	-	-	-	✓	-

<sup>1)</sup> Replace the oil every 25 hours if the engine is working at full load or at high temperatures.  
<sup>2)</sup> Clean the air filter more often if the machine is working in dusty areas.

For operations beyond the client's capability, the Service Centre should see to keeping the engine in perfect working order by:

- Tuning the engine whenever possible.
- Recommending the client a routine maintenance program at set intervals (e.g. at the end of the season or before a long period of inactivity).

### B) Engine tuning program

Whenever the Service Centre is asked to service a lawnmower or tune an engine, it should follow a series of operations to ensure the engine is kept fully serviceable.

Tuning should involve:

- external blowing and cleaning the cylinder head, cylinder and muffler by removing any remains of grass and mud;
- checking the oil level, topping up or replacing parts if necessary;
- inspecting the condition of the starter rope and checking that it functions correctly;
- cleaning and oiling the air filter [↔ 6.3.A];
- emptying and cleaning the fuel tank and checking the breather pipe [↔ 6.1];

- adjusting minimum and maximum speeds [↔ 6.4 and 6.5];
- inspecting the condition of the spark plug and ignition cable; checking the distance between the electrodes [↔ 6.6];
- tightening the screws [↔ 6.9];
- functional test [↔ 4.1.C].

Should the checks and adjustments fail to achieve a satisfactory result, refer to chapter 5 for troubleshooting.

### C) Functional test

A functional test needs to be carried out at the end of each servicing operation, to check that the operations made are effective.

The test must be performed in compliance with the safety regulations regarding the use of the lawnmower on which the engine is installed.

The functional test is carried out as follows.

#### 1. Refuelling and checking the supply system.

When you have refuelled the tank with new petrol, check the seal of the tank, the cap and the carburettor pipe.

**2. Cold starting test.** With the throttle control in "CHOKE", start the engine a few times to check it runs normally.



**3. Check the engine rpm.** When the engine is hot enough, check the engine speed with the throttle control set to "SLO" and "FAST"; the readings should be equal to the specifications [↔ 3.1.B].

**4. Hot start test.** With the engine hot and the throttle control set to "SLOW", start the engine a few times to check it runs normally.

**5. Engine brake and stopping test.** If you release the lawnmower brake lever, the engine should turn off instantaneously and decisively, and the rotation should stop within 3 seconds.

If all of these operations have a positive result, the engine can be considered fully serviceable and be returned to the client.



 	<b>5.1.1</b> <b>TROUBLESHOOTING</b>	 	from 2007 to page 1 / 7 
--	--	--	--

A) The engine does not start		
Probable cause	Comment	Solution

**Lawnmower problems**

The engine brake cable is faulty or unfastened	The cable control does not activate the coil earth switch.	Adjust and/or replace the cable [ <a href="#">↖ 6.7.A</a> ]
--	--	---

**Electrical problems**

The microswitch is faulty	The coil earth connection is not cut if the contacts inside the microswitch remain glued together.	Replace the micro-switch [ <a href="#">↖ 6.7.B</a> ]
---------------------------	--	--

Electric current does not reach the spark plug	<p>The spark plug is badly connected, faulty or the electrodes are too far away.</p> <p>The coil is faulty and does not supply current or the air gap is too large.</p>	Check the spark plug and the efficiency of the ignition system with the spark test [ <a href="#">↖ 6.6.A</a> ]
--	---	--

**➤ SV200ES - R200ES:  
Electric starting system problems**

Starter motor does not run due to:







Flat battery	If the machine's battery is discharged, it will not deliver current.	Check and recharge the battery
--------------	--	--------------------------------

	The alternator could be delivering insufficient current to keep the battery charged.	Check the charging system [ <a href="#">↖ 6.11.D</a> ]
--	--	--

Battery inadequate	The battery could be charged, but have insufficient capacity.	Check that the battery corresponds to what is given in the machine specifications.
--------------------	---	--

Problems with the electric circuit and the devices fitted to the machine	The electric circuit could be interrupted by slackened-off electrical connections between the battery and the starter motor or due to inadequate earthing. The control devices (starter relay and key) could be defective.	Check all the electrical connections and the efficiency of the control devices fitted to the machine.
--	--	---

Electrical insufficiency of the starter motor	Wear or oxidation of the brushes, presence of oil on the collector and deterioration of the windings or rotor prevent the starter motor from working.	Dismantle the starter motor and check the electrical part [ <a href="#">↖ 6.11.C</a> ]
---	---	--

 	<b>5.1.1</b> <b>TROUBLESHOOTING</b>	 
		from 2007 to page  2 / 7 

The starter motor turns but cannot start the engine due to:

Battery insufficiently charged

If the machine's battery is insufficiently charged, the starter motor turns, but does not have enough power to start the engine.

Check and recharge the battery

The alternator could be delivering insufficient current to keep the battery charged.

Check the recharging system [\[↔ 6.11.D\]](#)

Mechanical inefficiency of the starter motor

An accumulation of dirt in the zone of the starter motor's pinion could prevent the pinion from meshing correctly.

Dismantle the motor and clean the pinion zone [\[↔ 6.11.B\]](#)

Broken flywheel

The breakage or abnormal wear of the flywheel teeth prevent correct meshing with the starter motor pinion.

Check and/or replace the flywheel [\[↔ 6.9.E\]](#)

### Engine block problems

Fouling in the combustion chamber

Fouling in the combustion chamber absorbs the fresh mixture, which makes starting difficult and may impair valve closure.

Dismount the cylinder head and remove fouling [\[↔ 6.9.C\]](#)

Insufficient pressure

The cylinder head screws can loosen causing the gasket to burn.

Dismount the cylinder head and replace the gasket [\[↔ 6.9.C\]](#)

The piston rings can wear out due to the passage of dust caused by an excessively dirty or unoled air filter or overheating due to the lack of oil.

Replace the rings [\[↔ 6.10.C\]](#)

Low compression can be due to the burning out or wear of the valves or seats, or to an incorrectly adjusted clearance.

Check the wear of the valves, grind the seats and adjust the clearance [\[↔ 6.9.D\]](#)

### B) The engine starts badly or kicks back

Probable cause	Comment	Solution
----------------	---------	----------

### Lawnmower problems

The lawnmower blade is loose

The loose blade stops the effect of the flywheel and the kick-back can make starting difficult

Check that the lawnmower blade and hub are securely fastened

 	<b>5.1.1</b> <b>TROUBLESHOOTING</b>	 
		from 2007 to page  3 / 7 

### Intake problems

Air filter is clogged up      The clogged filter can thicken the mixture flooding the engine      Check and clean the air filter [\[↔ 6.3.A\]](#)

### Carburation problems

Carburettor dirty      If the jet and the pipes inside the carburettor clog up, the petrol flow drops and the engine fails to function correctly.      Check and clean the carburettor [\[↔ 6.4.A\]](#)

Poor seal of carburettor needle valve      If the needle valve does not close, excess fuel in the float chamber can reach the combustion chamber through the intake manifold. This can flood the engine and be hazardous as the petrol can seep through the rings and reach the oil sump. When mixed with petrol, oil loses its lubricating properties and the engine deteriorates rapidly.      Clean the carburettor housing and needle valve [\[↔ 6.4.A\]](#) or replace the carburettor [\[↔ 6.4.B\]](#)

Choke blocked      The choke can get blocked in the closed position if the mixture is too oily.      Check and clean the carburettor [\[↔ 6.4.A\]](#) and the choke

### C) Starting is difficult and strains the rope

Probable cause	Comment	Solution
----------------	---------	----------

### Lawnmower problems

The lawnmower traction cable (if present) is bent, jammed or poorly adjusted      The engine must start with the lawnmower drive completely disengaged; a poorly adjusted cable can generate faulty resistance which makes starting more difficult.      Check and/or adjust the lawnmower traction cable

### Engine block problems

Oil in the cylinder head      If the engine is tilted with the spark plug at the bottom, oil may seep into the cylinder head through the rings. This causes excess pressure and a reduction of mixture in the combustion chamber.      Dismount the cylinder head and clean it [\[↔ 6.9.A\]](#)

Pressure reducer fault      The pressure reducer is a device with counterweights whose task is to keep the exhaust valve slightly open when starting to reduce compression and make starting easier. If this does not happen, starting will require greater force being applied to the rope to overcome the increased compression.      Check the pressure reducer and counterweights [\[↔ 6.10.B\]](#)

5.1.1 <b>TROUBLESHOOTING</b>	from 2007 to page ◀ 4 / 7 ▶
---------------------------------	--------------------------------

## D) The engine starts but does not run

Probable cause	Comment	Solution
<b>Supply problems</b>		
The tank cap has a clogged breather pipe	The clogged breather pipe in the tank stops the regular flow of fuel into the carburettor float chamber. When the fuel has run out in the float chamber, the engine stops. After a few minutes, the float chamber fills up and the engine is able to restart, only to stop soon after.	Clean and/or replace the cap [↪ <a href="#">6.1.C</a> ]
Fuel filter clogged	Inside the tank, the filter has a metal mesh which can clog up with dirt or with a film of old fuel	Empty and clean the tank [↪ <a href="#">6.1.B</a> ]

## Starting problems

Insufficient or no current to the spark plug	Poor connections of the electrical cables or malfunctioning parts can cause the lawnmower to function irregularly.	Check the spark plug and the efficiency of the ignition system with the spark test [↪ <a href="#">6.6.A</a> ]
--	--	---

## E) The engine is inefficient (insufficient power)

Probable cause	Comment	Solution
<b>Lawnmower problems</b>		
The throttle cable is not well adjusted	The throttle's "FAST" position may not correspond with the carburettor's "FAST" position, reducing the flow of mixture and hence the power.	Check and/or adjust the throttle cable [↪ <a href="#">6.5.A</a> ]
<b>Carburation problems</b>		
Carburettor dirty	If the jet and pipes inside the carburettor clog up, the petrol supply drops and the engine becomes less efficient.	Check and clean the carburettor [↪ <a href="#">6.4.A</a> ]
The governor malfunctions or there is a problem with the rods	<p>The governor lever transfers the movement of the internal counterweight device to the carburettor control rods; if the lever is not properly in phase with the pin it will not operate on the rods correctly.</p> <p>The governor rods are bent, deformed or do not move freely, preventing the governor from reaching its end-of-stroke.</p>	Check the entire governor system [↪ <a href="#">6.5</a> ]

<p>5.1.1 <b>TROUBLESHOOTING</b></p>	<p>from 2007 to</p> <p>page ◀ 5 / 7 ▶</p>
---	---

**Insufficient pressure**

The piston rings can wear out due to the passage of dust or overheating caused by the lack of oil.

Replace the rings  
[↩ 6.10.C]

The cylinder head screws can loosen causing the gasket to burn.

Dismount the cylinder head and replace the gasket [↩ 6.9.A]

Poor compression could be caused by the burning or wear of the valves or seats, or by an incorrectly adjusted gap.

Check the state of wear of the valves, grind the seats and adjust the gap  
[↩ 6.9.D]

**Environmental problems**

The engine is used at a high altitude

The rarefaction of air in the mountains causes a drop in power of approx. 10-12% every 1000 metres of altitude.

Suggest to the client that the effort of the machine is adapted to the reduced power available; if the lawnmower is used permanently at altitudes above 1200-1500 metres, the carburation can be adjusted to compensate for the reduced oxygen supply  
[↩ 6.4.E]

<b>F) The engine runs irregularly</b>		
Probable cause	Comment	Solution

**Carburation problems**

Air seeps into the carburettor

If air seeps through the gaskets, it can cause the lawnmower to function poorly and make it difficult to maintain the minimum speed (2200-2400 rpm).

Replace the carburettor gaskets [↩ 6.4.A]

The governor malfunctions or there is a problem with the rods

The governor lever transfers the movement of the internal counterweight device to the carburettor control rods; if the lever is not properly in phase with the pin it will not operate suitably on the rods.

Check the entire governor system [↩ 6.5]





The governor rods are bent, deformed or do not move freely, preventing the governor from reaching its end-of-stroke.

**Starting problems**

The coil air gap has been poorly adjusted

The air gap adjustment between the flywheel and coil must be 0.25-0.40 mm.

Adjust the air gap [↩ 6.6.B] and if the problem persists, replace the coil [↩ 6.6.C]

 	<b>5.1.1</b> <b>TROUBLESHOOTING</b>	 	from 2007 to page ◀ 6 / 7 ▶
--	--	--	--------------------------------

## G) The engine overrevved

Probable cause	Comment	Solution
----------------	---------	----------

### Carburation problems

Governor blocked	The breakage of the internal device counterweights does not allow opening of the butterfly to be opposed.  Excess dirt or a broken spring can impede the movements of the governor or impede return.	Check the entire governor system <a href="#">↩ 6.5</a>
------------------	--	---

## H) The engine does not turn off

Probable cause	Comment	Solution
----------------	---------	----------

### Lawnmower problems

The engine brake cable is bent or jammed	When the lever is released, the earth microswitch is not pressed.	Check and/or adjust the cable <a href="#">↩ 6.7.A</a>
--	---	---

### Electrical problems

The earth cable is disconnected or broken	The broken or disconnected cable prevents the microswitch from closing the electric circuit to earth	Check the earth connection <a href="#">↩ 6.7.B</a>
---	--	--

## J) The engine judders

Probable cause	Comment	Solution
----------------	---------	----------

### Lawnmower problems

Blade not balanced	The imbalanced or loose blade causes judders and the premature wear of all the parts inside the engine.	Dismount and balance the blade and tighten the screws to the specified levels
Engine screws loose	An engine with loose screws can be hazardous for the user and can break internal parts.	Tighten the screws to the specified levels <a href="#">↩ 6.10.A</a>
Engine shaft bent	An impact of the blade against an obstacle could lead to deformation of the engine shaft.	Replace the engine shaft <a href="#">↩ 6.10.C</a>

 	<b>5.1.1</b> <b>TROUBLESHOOTING</b>	 
		from 2007 to page  7 / 7

<b>K) The engine does not stop within 3 seconds after it has turned off</b>		
Probable cause	Comment	Solution

**Problems with the stopping system**

Faulty or no clutch lining	The thickness of the clutch lining normally guarantees good braking action for the entire duration of the engine. If it comes away from the lever, act immediately to stop the metal from rubbing against the fly-wheel causing hazardous sparks.	Replace the engine stopping system <a href="#">[↩ 6.7.D]</a>
----------------------------	--	---

<b>L) The engine uses a lot of oil</b>		
Probable cause	Comment	Solution

**Engine block problems**

Defective breather valve operation	The breather valve allows oil vapours to reach the carburettor and so to be burned with the air/petrol mixture; if the valve remains open, oil could also pass through it, causing white smoke from the exhaust.	Check and/or replace the breather valve <a href="#">[↩ 6.9.F]</a>
Poor piston ring seal	The piston rings can wear out due to the passage of dust caused by an excessively dirty or unoled air filter or overheating due to the lack of oil; in any case, the oil can pass into the combustion chamber.	Replace the rings <a href="#">[↩ 6.10.C]</a>
Excessive gap between the guide and the inlet valve stem	The excessive gap causes oil to blow back into the combustion chamber during the inlet phase.	Check and/or replace the valve <a href="#">[↩ 6.9.D]</a>
Ring assembly error	If the piston rings have been assembled with their openings aligned with each other (and facing downwards), oil could pass into the combustion chamber.	Check the assembly of the rings <a href="#">[↩ 6.10.C]</a>

<b>M) The battery does not hold the charge or swells (only for SV200ES and R200ES)</b>		
Probable cause	Comment	Solution

**Alternator problems**

Insufficient or excessive recharging	The alternator should deliver a current of between 0,45 and 0,55 Amps inclusive at 2800 rpm. An insufficient charge does not retain the optimal battery charge, which discharges more rapidly, while an excessive charge causes obvious swelling of the casing.	Check the recharging system <a href="#">[↩ 6.11.D]</a>
--------------------------------------	---	--



## 6.1.1 TANK AND SUPPLY



from 2007 to  
page 1 / 3

### 6.1 TANK AND SUPPLY

#### GENERAL INFORMATION

The supply system consists of a petrol tank connected to the carburettor by a pipe. A mesh filter on the bottom of the tank stops deposits and impurities from reaching the carburettor.

The supply to the carburettor float chamber is caused by gravity and the volume of petrol taken from the tank as the engine runs is compensated by a breather pipe in the cap.

The supply system can malfunction in the following ways:

- difficult or failed start or insufficient power (if not due to other causes):
  - = Petrol filter dirty [↔ 6.1.B];
  - = Petrol pipes clogged
  - = Inefficient breather pipe [↔ 6.1.C].

#### SERVICING PROCEDURES



**WARNING!** All work on the tank and on the supply system must be carried out in safe conditions, so:

- do not smoke;
- always empty the tank;
- work in a ventilated environment away from naked flames or unprotected sources of heat;
- collect petrol in a suitable container with a cap using a funnel and avoid spilling it on the work bench;
- remove all traces of spilt petrol immediately;
- check you have connected the pipes before pouring petrol back into the tank.

#### A) Emptying and removing the tank

- 1 Remove the starting system [↔ 6.2.A].
- 2 Remove the clip (1) from the petrol pipe (2) on the carburettor side and collect all the fuel present in the tank and pipe in a suitable container.
- 3 Unscrew the rear screw (3) and detach the tank (4) from the two studs (5).

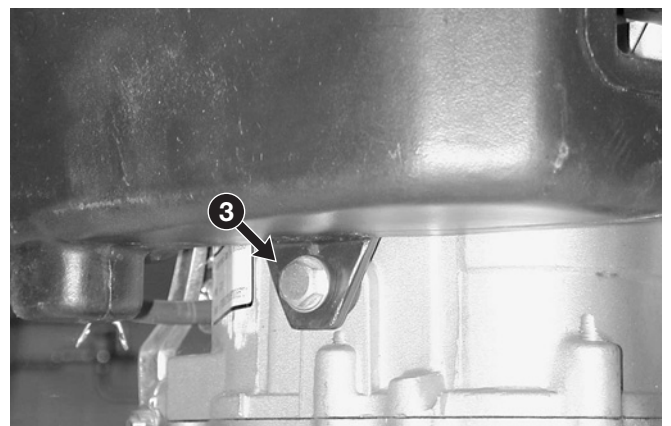
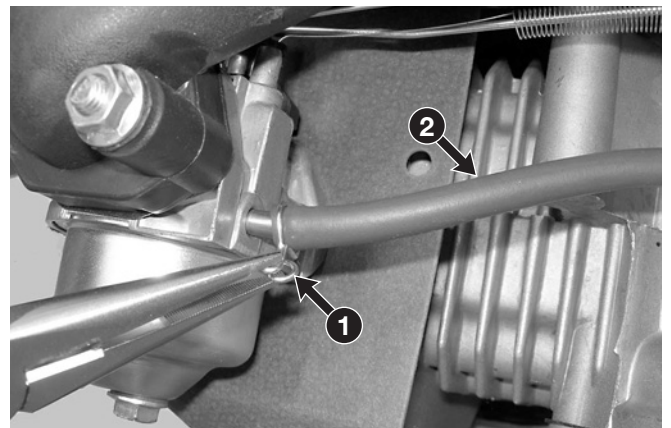
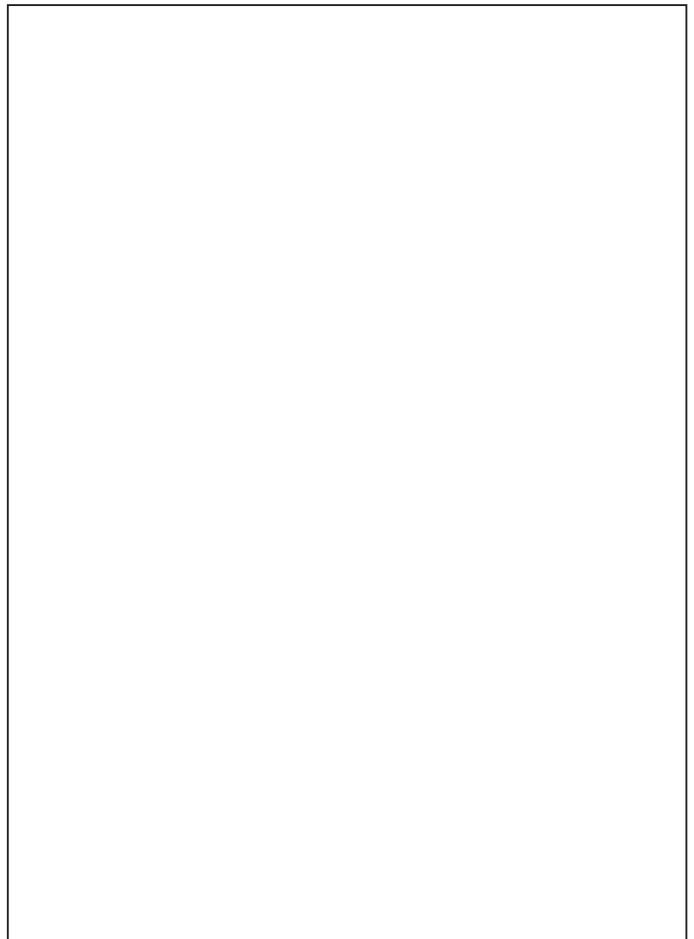





## 6.1.1 TANK AND SUPPLY



from 2007 to  
page ◀ 2 / 3 ▶

- 4 To reassemble, reverse the order of the previous operations.
- 5 Remount the starting system [↔ 6.2.A].



**WARNING!** Check that the petrol pipe (4) is intact and secured correctly before pouring in new fuel.

### B) Cleaning the tank

- 1 Remove the starting system [↔ 6.2.A].
- 12 Remount the tank [↔ 6.1.A].
- 13 Remove the clip (6) from the side of the tank and disconnect the petrol pipe (2).
- 14 Pull out the stalk of the filter (7) and blow compressed air so as to remove the deposits present inside.
- 15 Keep the tube hole (8) closed, pour in approx. 100 cl of clean petrol and shake well to clean inside the tank.
- 16 Empty the tank and dispose of the petrol used for cleaning in accordance with the laws in force.
- 17 Remount the tank [↔ 6.1.A].
- 18 Remount the starting system [↔ 6.2.A].



**WARNING!** Check that the petrol pipe (4) is intact and secured correctly before pouring in new fuel.

### C) Checking and cleaning the breather pipe

- 21 Remove the cap (21) and pull out the gasket (22) and the sponge (23).
- 22 Check that:
  - the gasket (22) is intact and without cracks or fissures;

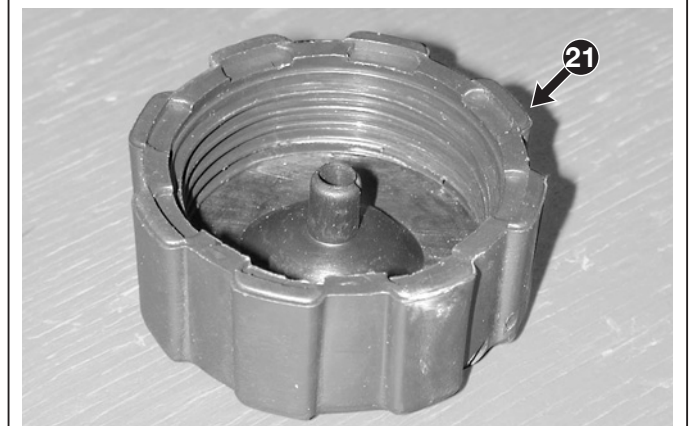
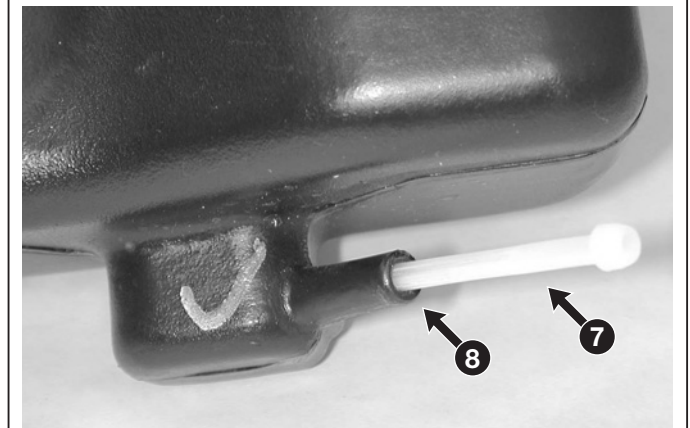
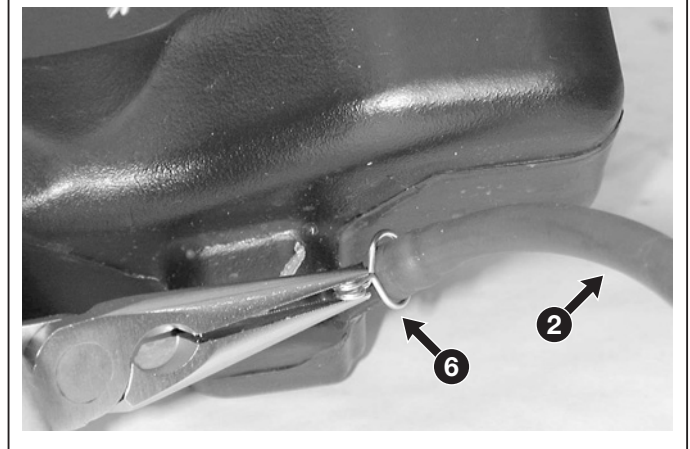
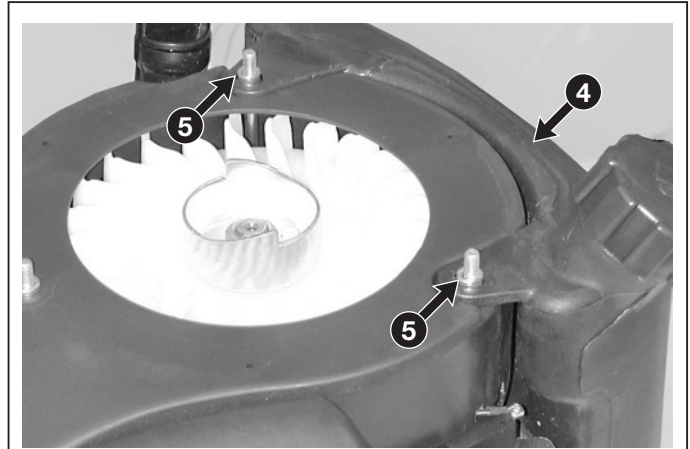



## 6.1.1 TANK AND SUPPLY



from 2007 to

page ◀ 3 / 3

- the air passages (24) inside the cap are not clogged;
- the sponge (23) is not crushed or broken.

**NOTE**

Always replace the entire cap if the gasket or sponge is damaged

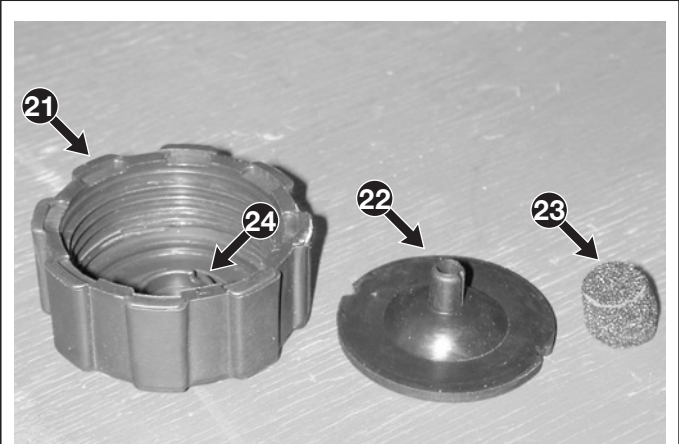

**Tightening torque**

**3** Tank fastening screw ..... 5-7 Nm



## 6.2.1 STARTING SYSTEM

from 2007 to  
page 1 / 2

### 6.2 STARTING SYSTEM

#### GENERAL INFORMATION

The starting system consists of a cable wound onto a pulley and consists of a rope wound onto a pulley. The movement from the pulley to the flywheel (and the engine shaft) is transmitted by a pair of hooks. The rope is returned and rewound by a spiral spring.

Other than the possibility of the rope breaking, the starting system may malfunction in the following ways:

- the engine does not start (if not due to another causes):  
= rope too short, not providing an adequate number of revs to the engine [↔ 6.2.A].
- the pulley fails to couple with the flywheel, noticeable by the rope unwinding without effort:  
= damaged or broken hooks [↔ 6.2.B].
- the rope returns uncertainly or does not return:  
= broken spring [↔ 6.2.C].

In all cases, remove the starting system to make the necessary checks or repairs.

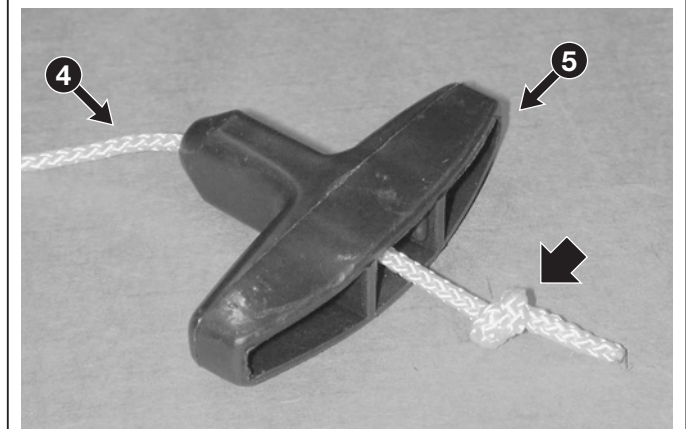
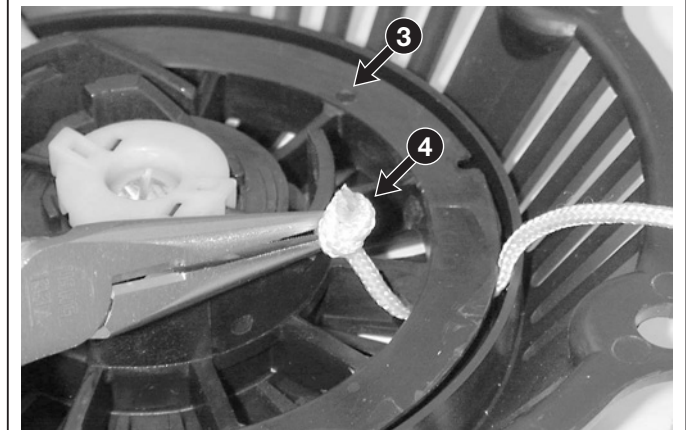
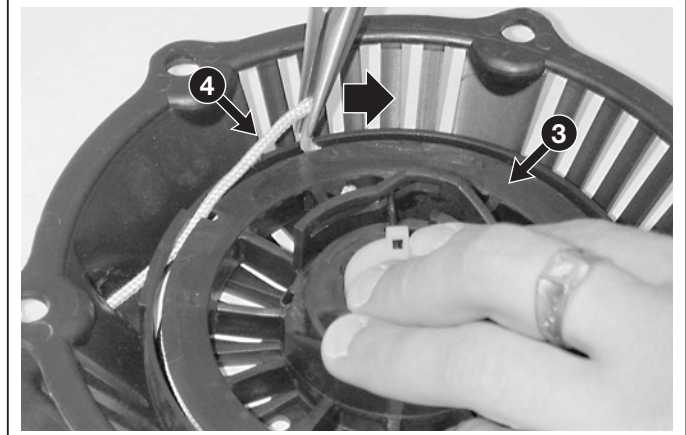
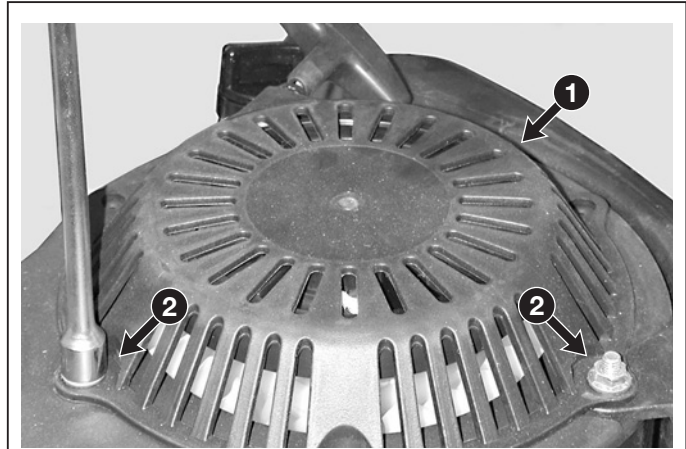

#### SERVICING PROCEDURES

##### A) Removing the starting system

- 1 The starting system (1) can be accessed after removing the possible outside cowls and it is fixed by three nuts (2).

##### B) Replacing the rope

- 11 Remove the starting system [↔ 6.2.A].
- 12 Keep hold of the pulley (3) and slowly unwind (clockwise) the entire rope (4) to gradually release the return spring. If the rope breaks, the spring will be already released and you will only have to unwind the rope.
- 13 Undo or cut the knot at the end of the rope or remove the section still attached to the pulley.

- 14 Pass one end of the cable (4) (Ø 4.5 mm - length 2.40 m) through the ventilation grille into the hole in the pulley (3) and make a knot so that it cannot escape.
- 15 Insert the other end of the rope (2) into the grip (3) and fasten it with a knot.
- 16 Turn the pulley (3) and the rope (4) anticlockwise for 6 complete turns in order to load the spring, then release the pulley carefully to wind the entire rope onto the pulley.
- 17 Check that the pulley (1) rotates freely.
- 18 After pulling the entire length of the rope, check that the pulley (3) is able to complete another 2-3 turns before compressing the spring.
- 19 Remount the starting system [↩ 6.2.A].

### C) Replacing the hooks

- 21 Remove the starting system [↩ 6.2.A].
- 22 Loosen the central screw (6) and dismount the bushing (7) and hooks (8) without letting the pulley (3) slip out of place.

**NOTE**

The screw (6) has a left-handed thread and therefore should be **unscrewed clockwise**.

**NOTE**

Always replace the hooks (8), the bushing (7) and the screw (6) in one block.

- 23 Mount the new hooks (8), taking care to position them correctly with the bushing (7) and the guides in the pulley hub (3). Tighten the screw (6) **anticlockwise** so that the pulley rotates smoothly.
- 24 Remount the starting system [↩ 6.2.A].

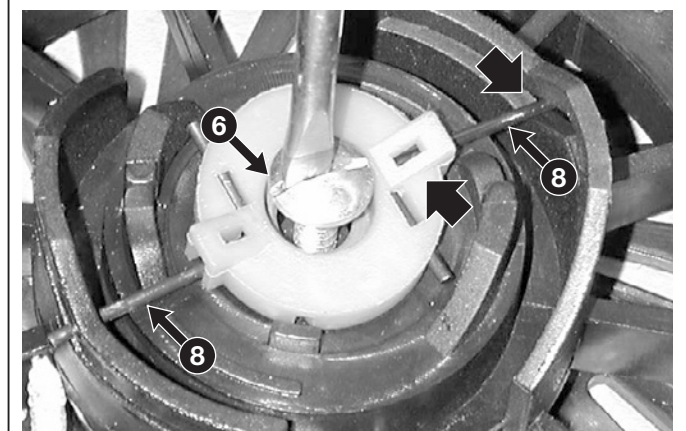
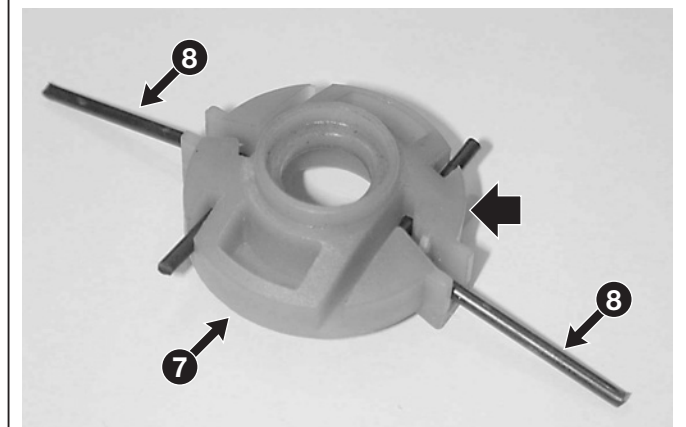
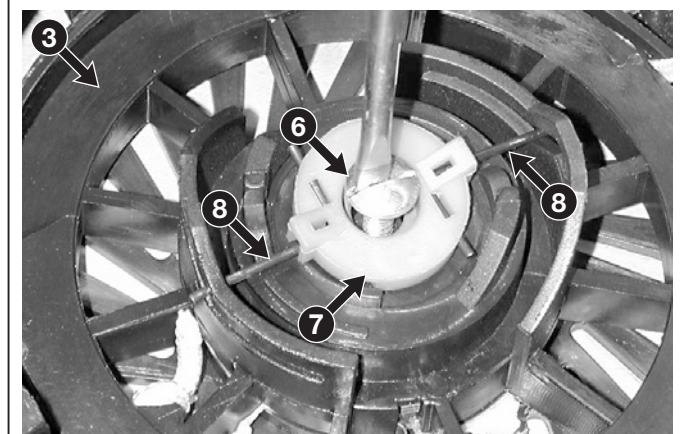
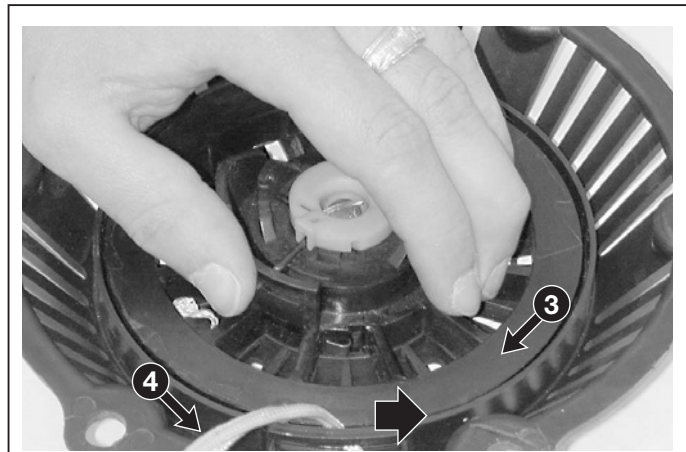

### Tightening torques

- |          |                                   |        |
|----------|-----------------------------------|--------|
| <b>3</b> | Starting system fixing nuts ..... | 5-6 Nm |
| <b>6</b> | Starter screw .....               | 4-6 Nm |

### Technical information

Starter rope dimensions ..... Ø 4.5 - 2.4m



## 6.3.1 INTAKE SYSTEM

from 2007 to  
page 1 / 1

### 6.3 INTAKE SYSTEM

#### GENERAL INFORMATION

The intake system uses an air filter which is directly connected to the carburettor by means of a manifold which conveys the air/petrol mixture towards the induction valve.

The intake system can malfunction in the following ways:

- difficult or failed start or insufficient power (if not due to other causes):  
= Air filter clogged [ [6.3.A](#)];

An inefficient filter can let dust or debris enter the cylinder, causing premature wear to the piston rings and cylinder.

The air filter is found on the left hand side of the engine and can be inspected without having to remove other parts.

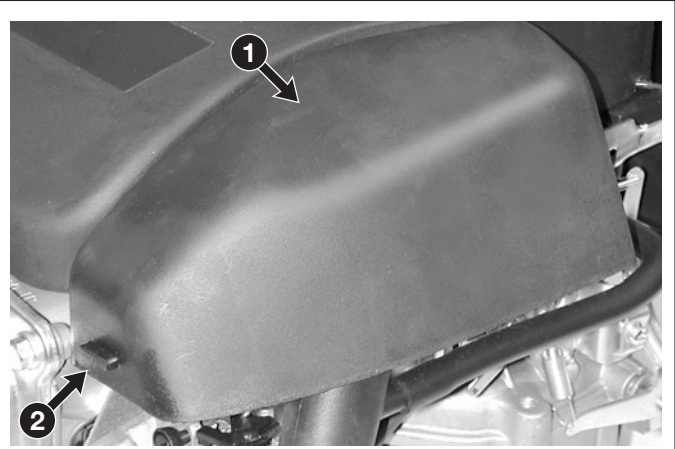

#### SERVICING PROCEDURES

##### A) Maintenance of filtering element

- 1 Clean around the filter cover (1).
- 2 Remove the cover (1) by releasing the flap (2) and remove the sponge filtering element (3).

**IMPORTANT!** The filtering element must be kept clean and soaked in oil. Replace it if broken, cracked or fragmented. Do not use compressed air for cleaning the filtering element.

- 3 Wash the foam element in liquid detergent and water. Squeeze dry in a clean cloth.
- 4 Saturate the foam element (3) with 2 table-spoons of clean engine oil and squeeze it a few times to distribute the oil evenly (4).
- 5 Remove excess oil with a clean cloth.
- 6 With a jet of compressed air, clean inside the seat (5) of the filter by removing dust and remains of grass, making sure that the intake pipe hole (6) is closed so that nothing gets inside the pipe.
- 7 Install the foam element (3) in its housing and refit the cover (1).

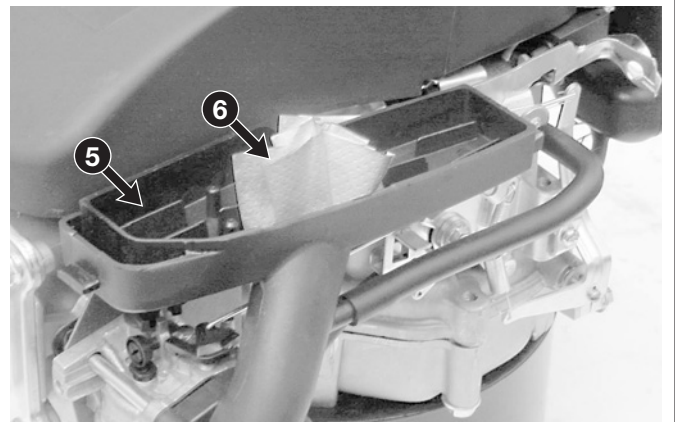
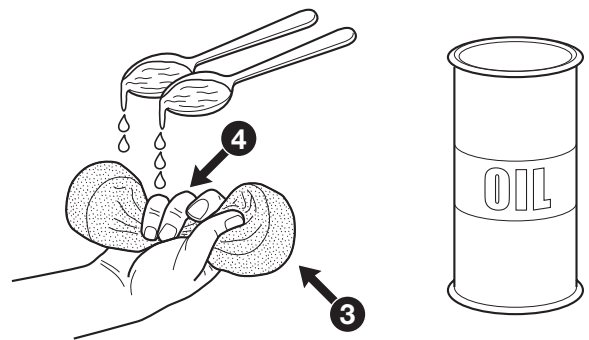



## 6.4.1 CARBURATION

from 2007 to  
page 1 / 3

### 6.4 CARBURATION

#### GENERAL INFORMATION

The carburettor has a float with a fixed jet and a "CHOKE" control.

The carburettor can malfunction in the following ways:

- difficult or failed start or insufficient power (if not due to other causes):  
= Carburettor dirty [↖ 6.4.A].
- engine runs irregularly (if not due to other causes):  
= Air has seeped into the carburettor [↖ 6.4.A].

#### SERVICING PROCEDURES



**WARNING!** All operations on the tank and supply system must be carried out in safe conditions, so:

- do not smoke;
- always empty the tank if petrol is not strictly necessary for the operation to be carried out;
- work in a ventilated environment away from naked flames or unprotected sources of heat;
- collect petrol in a suitable container with a cap using a funnel and avoid spilling it on the work bench;
- remove all traces of spilt petrol immediately;
- check you have connected the pipes before pouring petrol back into the tank;

#### A) Removing and cleaning the carburettor

- 1 Remove the clip (1) from the petrol pipe (2) on the carburettor side and collect all the fuel present in the tank and pipe in a suitable container.
- 2 Pull out the exhaust pipe (3) and remove the intake manifold (4) fixed by the two nuts (5).
- 3 Partially pull out the carburettor (6) and disconnect the tie-rod (7) and spring (8) from the throttle butterfly lever (9).

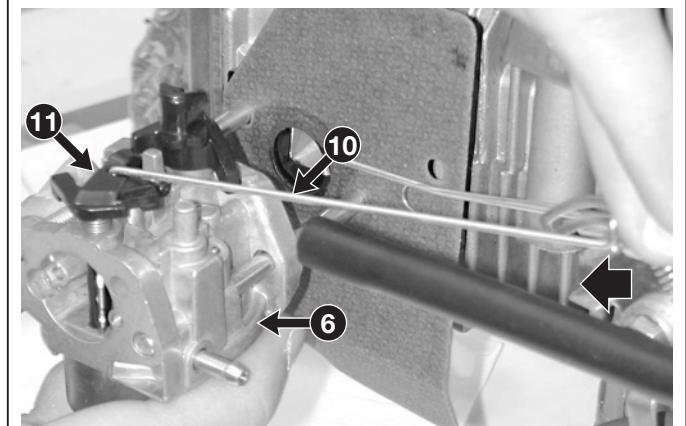
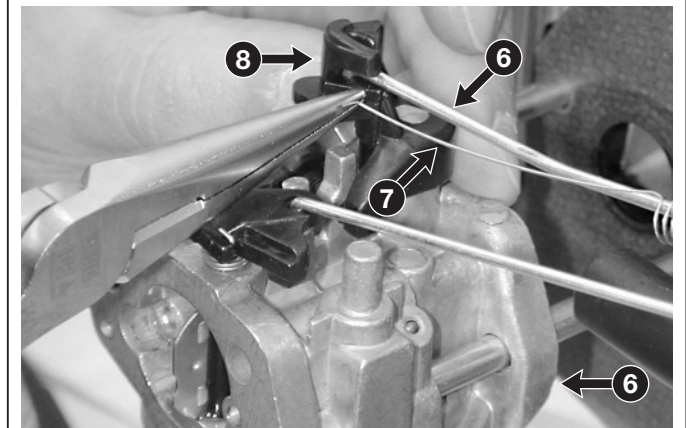
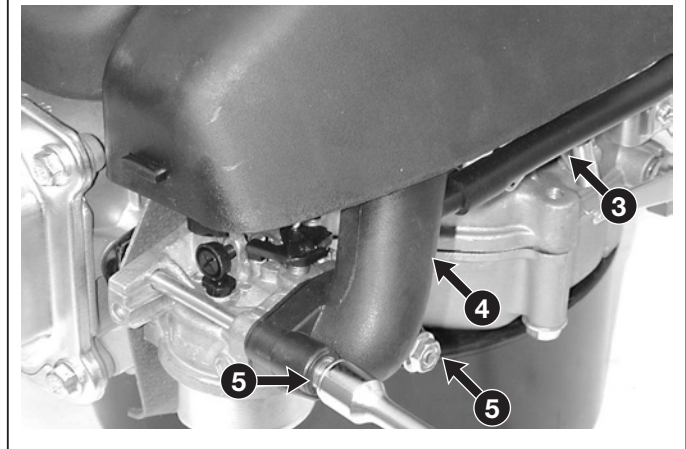
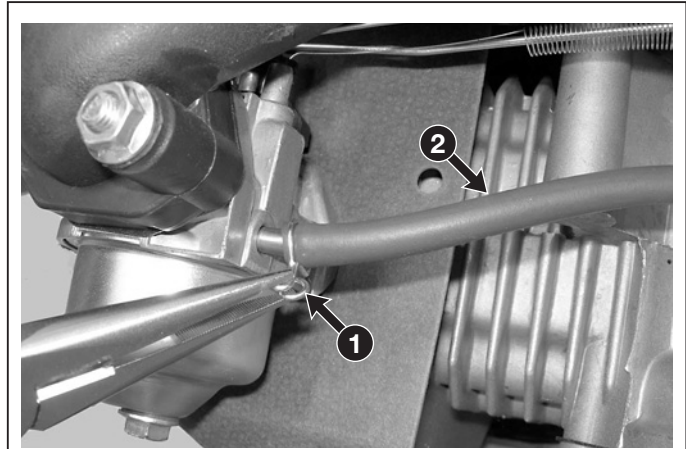



## 6.4.1 CARBURATION

from 2007 to  
page 2 / 3

- 4 Completely pull out the carburettor (6) to allow the tie-rod (10) to be disconnected from the starter butterfly lever (11) and remove the carburettor. The operation is facilitated by pushing the regulator group lever forward.
- 5 Loosen the central screw (12) fastening the float chamber (13) and carefully collect all the petrol left in the float chamber.
- 6 Pull out the pin (14), dismount the float (15) and remove the gasket (16).
- 7 Undo the screw (17) and pull out the jet (18).
- 8 Clean the jet and the carburettor thoroughly by immersing them in clean petrol (or a detergent) for 24 hours. Dry with compressed air, blowing well through the carburettor holes.
- 9 Mount the carburettor following the previous points 7, -6 and 5 in reverse order, remembering that:
  - it is always advisable to replace the gasket (16) and the washer underneath the screw (12);
  - the float (15) must oscillate freely on the pin (14);
  - the jet (18) should never be modified or replaced with others even if they seem to have the same specifications;
  - the choke (19) must open and close regularly;
  - the float chamber drain screw (20) must be facing forwards.
- 10 The gasket (21) must always be replaced on reassembly; reverse the operations described, being careful about the correct positioning of the tie-rods (6) and (10) and spring (4), checking that the movements with respect to the adjustment system are smooth and without hold-ups.

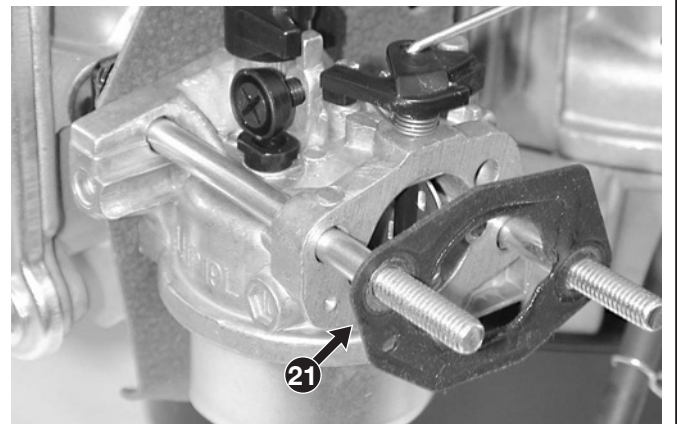
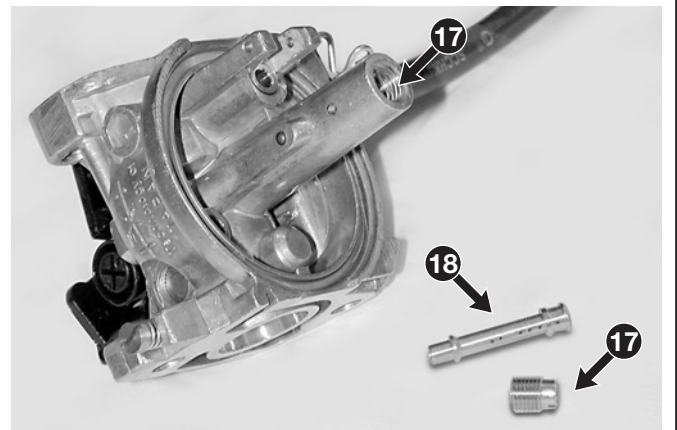
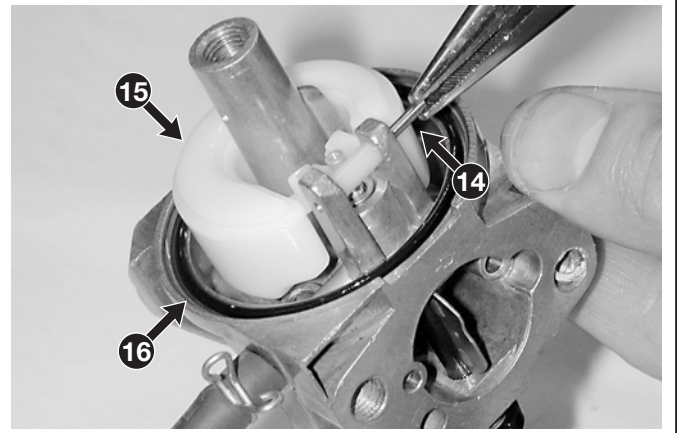
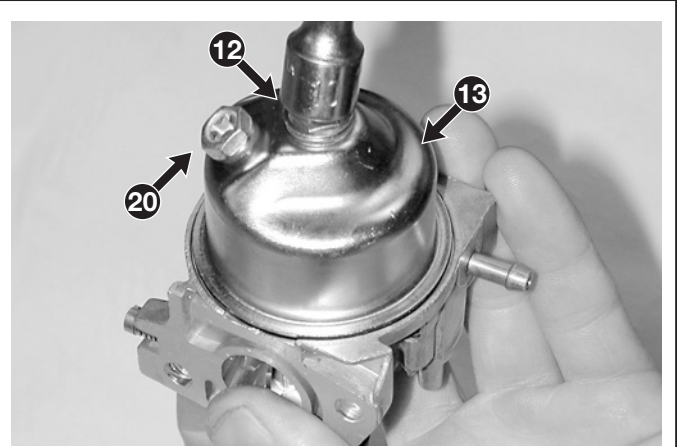



## 6.4.1 CARBURATION



from 2007 to  
page 3 / 3

### B) Replacing the carburettor

- Follow steps 1 - 2 - 3 - 4 - 10 of the procedure described in point "A".

### C) Adjusting minimum speed

- 21 Check that the throttle cable is adjusted correctly [↔ 6.5.A].
- 22 Let the engine heat up for a few minutes, then set the throttle control to "SLOW". Check the rotation speed on the speed indicator (31).

**NOTE**

The engine's minimum speed must be between 2200 and 2400 rpm.

- 23 Turn the screw (32) until you achieve a stable minimum speed within the above values.

### D) Adjusting maximum speed

**NOTE**

This operation is carried out by adjusting the governor system [↔ 6.5.B].

### E) Adjusting the carburation

**NOTE**

The carburation is set in the factory and does not normally need changing. In special cases such as, for example, if the lawnmower is used at altitudes above 1200-1500 metres, it could be advisable to modify the initial calibration. The following must be borne in mind when adjusting:

- carburation that is too lean leads to irregular operation and difficulty in keeping the revolution speed constant;
- carburation that is too rich causes the engine to flood.

- 31 Carburation adjustment is done using screw (33):
  - screwing in, to reduce the amount of fuel;
  - screwing out, to increase it.

**NOTE**

To reset the optimal condition, fully tighten screw (34) and then unscrew it by about 1.5 – 2 turns.

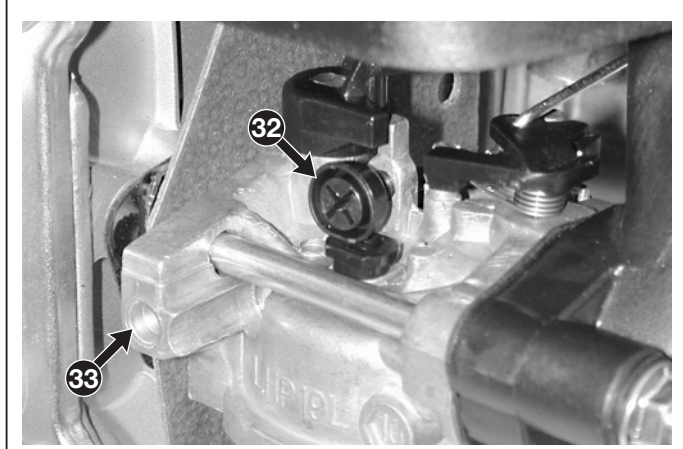

#### Tightening torques

- 5 Inlet manifold fixing nuts ..... 8-10 Nm

#### Technical information

Minimum speed (SLOW) ..... 2200-2400 rpm

#### Special equipment

- 21 Speed indicator



6.5.1	from 2007 to
<b>GOVERNOR SYSTEM OF THE CARBURETTOR</b>	page 1 / 3

## 6.5 GOVERNOR SYSTEM OF THE CARBURETTOR

### GENERAL INFORMATION

The carburettor governor system uses a rod linkage fitted on a support fixed to the left-hand side of the engine, completed by a counterweight device, driven by the camshaft, and thus sensitive to changes in the engine's revolution pattern depending on load.

The force of the counterweights, transferred to the control lever, tends to shut the main carburettor butterfly, in opposition with the spring that would keep it open; the balance between the spring loading and the thrust of the counterweights on the control lever modifies the butterfly opening and adapts the flow of fuel to the engine so that the revolution speed is kept constant with engine load changes..

The governor system can malfunction in the following ways:

- difficult or failed start or insufficient power (if not due to other causes):
  - = Incorrect adjustment of the throttle cable [[↔ 6.5.A](#)];
  - = rods bent or deformed [[↔ 6.5.B](#)];
  - = counterweight device broken or stopped [[↔ 6.10.B](#)].
- Engine runs irregularly (if not due to other causes):
  - = Counterweight device broken or stopped [[↔ 6.10.B](#)].
- Engine exceeds the maximum rev limit (if not due to other causes):
  - = Counterweight device broken or stopped [[↔ 6.10.B](#)].

### SERVICING PROCEDURES

#### A) Adjusting of accelerator cable

- 1 Loosen the screw (1) of the clamp (2) so that the cable casing (3) is free to move.
- 2 Set the throttle control lever to "CHOKE".
- 3 Move governor control lever (4) forward as far as possible and, by keeping it in this position, lock the casing (3) full tightening the screw (1) of the clamp (2).

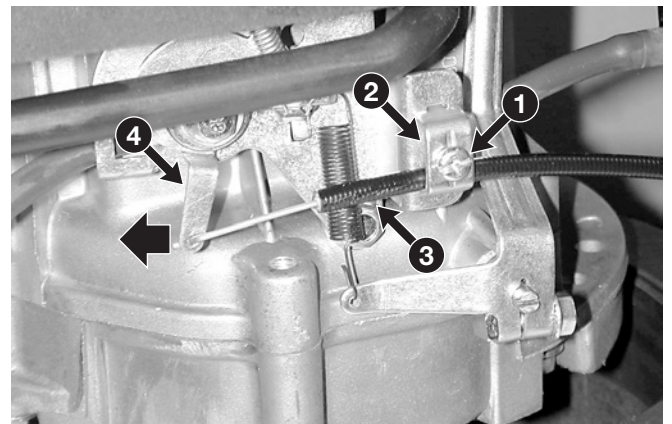
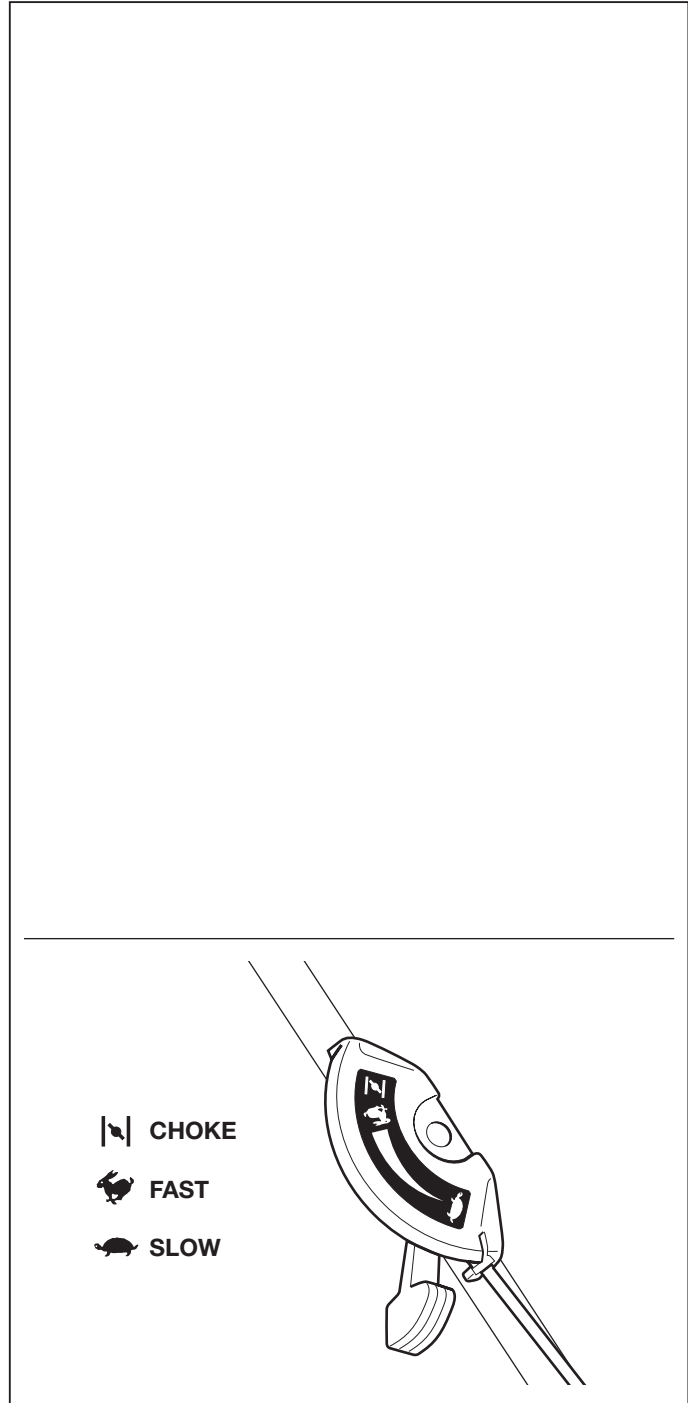

<p>6.5.1</p> <p><b>GOVERNOR SYSTEM OF THE CARBURETTOR</b></p>	<p>from 2007 to</p> <p>page 2 / 3</p>
---	---------------------------------------

## B) Adjusting maximum speed

- 11 Check that the throttle cable is adjusted correctly [[6.5.A](#)].
- 12 Let the engine heat up for a few minutes then set the throttle control to "FAST". Check the rotation speed on the speed indicator (21).

**NOTE**

The engine's maximum speed must be between 2700 and 2900 rpm; if you do not read this value, proceed as follows

- 13 Check:

- that the spring (22) is intact;
- that the tie-rod (23) and relative spring (24) are intact and undamaged;
- that the moving levers (24) are not bent or deformed and replace the entire support if necessary [[6.5.C](#)].

- 14 If the above checks do not show any faults, the phasing of the governor's control lever (26) with respect to the counterweight device must be checked:

- stop the engine and move the accelerator control to "FAST";
- slacken off the control lever (26) locknut (27);
- without changing the lever (26) position determined by the spring (22) and tie-rod (23), use a screwdriver to turn pin (28) clockwise to the end of its stroke and then lock the nut (27).

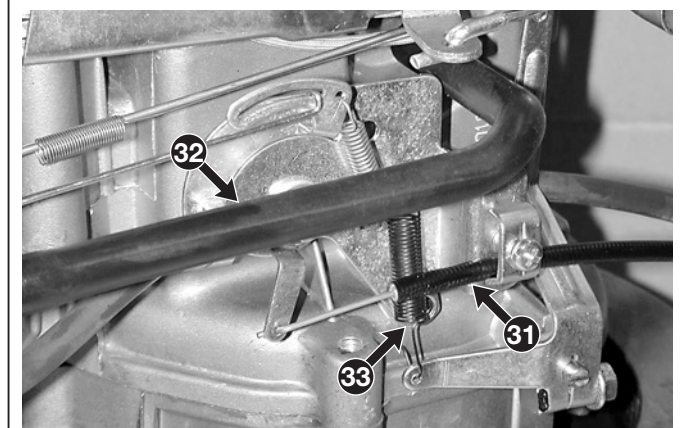
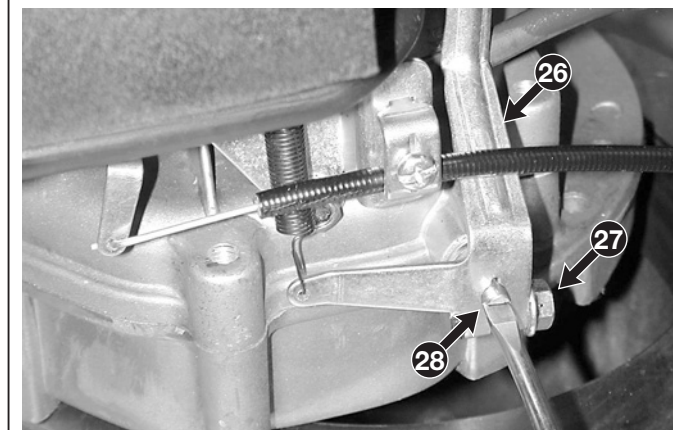
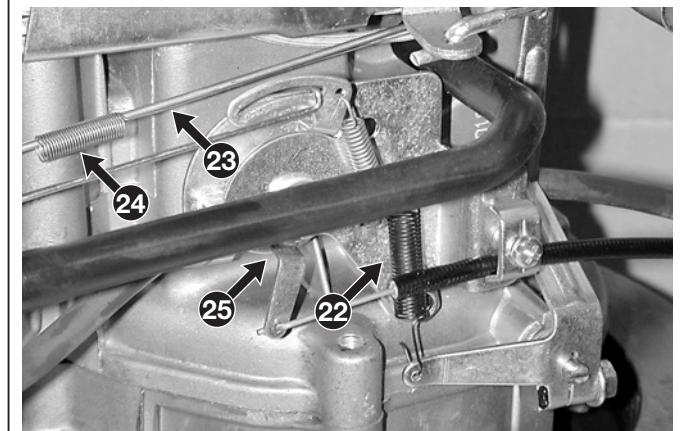

## C) Replacing the lever system support

- 21 Remove the intake manifold and the carburettor [[6.4.A](#)].
- 22 Disconnect the accelerator cable (31) and remove the breather pipe (32) and the spring (33).



**6.5.1**  
**GOVERNOR SYSTEM OF THE CARBURETTOR**



from 2007 to  
page ◀ 3 / 3

- 23 Disconnect the air butterfly tie-rod (34) and unscrew the two screws (35) fixing the support (36) to the engine.
  
- 24 On assembly, follow the steps described in reverse.
  
- 25 Remount the intake manifold and the carburetor [↩ [6.4.A](#)].
  
- 26 Adjust the maximum speed [↩ [6.5.B](#)].

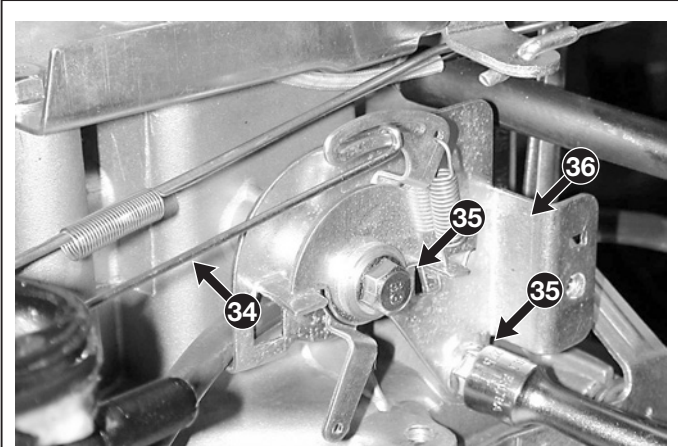

---

**Tightening torques**

---

**35** Governor support fixing screws ..... 8-10 Nm

---

**Technical information**

---

Maximum speed (FAST) ..... 2700-2900 rpm

---

**Special equipment**

---

**21** Speed indicator

6.6.1 <b>IGNITION SYSTEM</b>	from 2007 to page 1 / 3
---------------------------------	----------------------------

## 6.6 IGNITION SYSTEM

### GENERAL INFORMATION

The ignition system has a flywheel with an electronic coil which supplies high voltage to the spark plug.

The starting system can malfunction in the following ways:

- the engine does not start (if not due to another cause):
  - = no spark on the spark plug due to a faulty coil [↔ 6.6.A];
  - = coil to earth [↔ 6.6.B and 6.7.B];
  - = incorrect adjustment of the air gap [↔ 6.6.B];
  - = faulty spark plug or wrong distance between the electrodes [↔ 6.6.A];
  - = oxidized or loose contacts [↔ 6.6.B].
- engine runs irregularly (if not due to other causes):
  - = incorrect adjustment of the air gap [↔ 6.6.B];
  - = oxidized or loose contacts [↔ 6.6.B].

For access to the coil and the flywheel, remove the upper conveyor.

### SERVICING PROCEDURES

#### A) Checking the efficiency of the ignition system

1 Dismount the spark plug (1) and look at the colour on the end of the thread. This can give you a good idea of the carburation:

- black = mixture too greasy due to clogged air filter;
- nut brown = regular carburation.

Replace the spark plug if the electrodes (2) are burnt or if the porcelain is broken or cracked.



#### WARNING! Fire hazard:

- do not check the ignition system if the spark plug is not screwed in place;
- always use the specific tool for the spark test.

2 Connect the tester (3) to the spark plug cap (4)

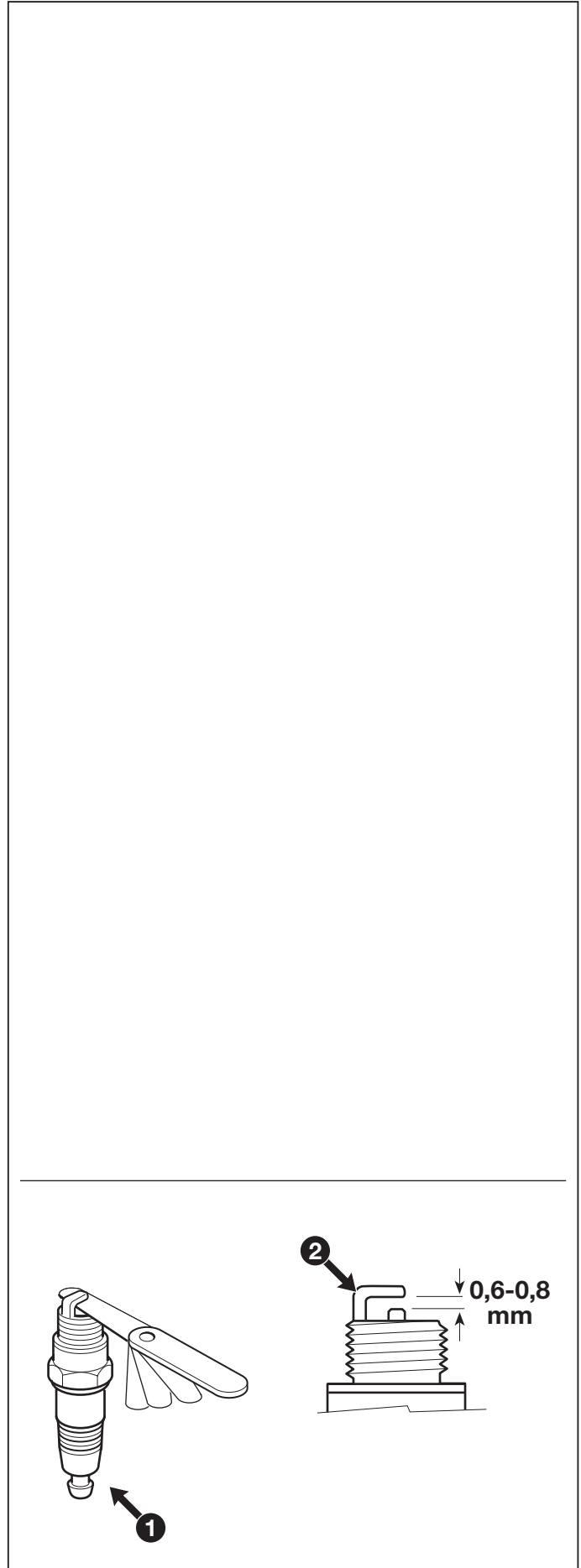



## 6.6.1 IGNITION SYSTEM

from 2007 to  
page 2 / 3

and to earth on the engine (5). Activate the starter and see in the instrument if the spark jumps.

- If the test has a positive result, clean the electrodes (2) with compressed air and adjust the distance to 0.6-0.8 mm. Remount the spark plug and tighten it to the specified levels.

Otherwise, check the system parts as described in point "B".

### B) Adjusting the air gap and checking the coil

- Remove the starting system [↔ 6.2.A].
- Remove the tank [↔ 6.1.A].
- Remove the conveyor (10).
- Make sure that the earth cable faston (11) of the coil (12) is not oxidized; if it is, disconnect, clean and remount it, spraying it with a special antioxidant.
- Make sure that the earth cable (11) is intact. The black spark plug cable (13) should not have any cracks or signs of deterioration or burns which reduce its efficiency and insulation level.
- Loosen the screw (14) and the stud bolt (15) securing the coil (12), release the brake manually and rotate the flywheel (16) until the magnetic inserts are lined up with the poles of the coil core (12).
- Insert a 0.35 mm thickness gauge (17) between the flywheel (16) and the coil poles. Push the coil until the poles come in contact with the thickness gauge and secure screw (14) and stud bolt (15). Tighten the screws remembering that the air gap must be between 0.25 and 0.40 mm.

#### NOTE

An accurate inspection of the efficiency of a coil can only be carried out in a laboratory equipped with an oscilloscope. To make a brief check, proceed as follows:

- Disconnect the faston of the black earth cable (11) and reposition the upper conveyor to activate the starter.

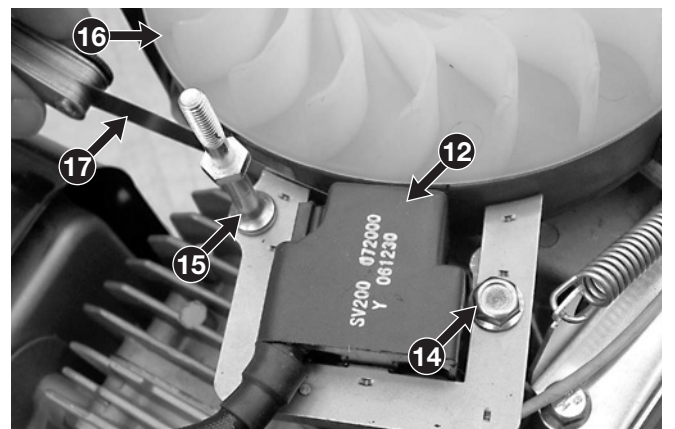
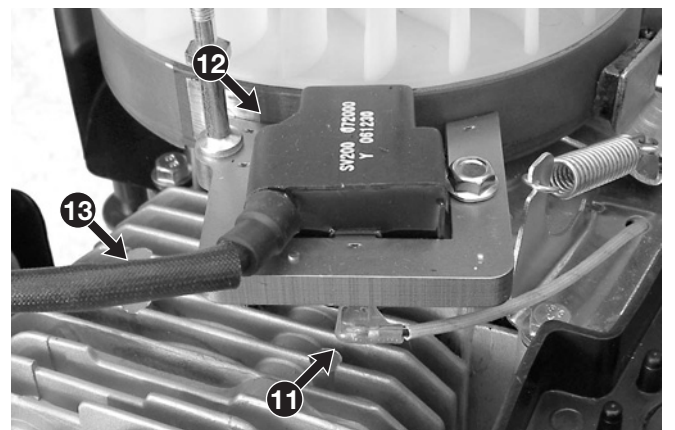
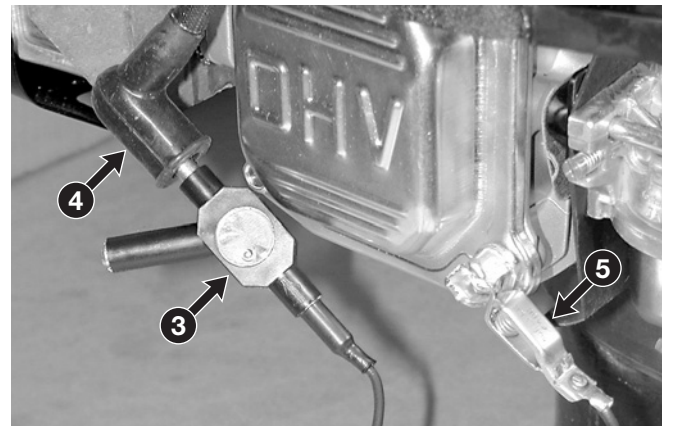



## 6.6.1 IGNITION SYSTEM

from 2007 to  
page 3 / 3

19 Carry out a spark test as described in point "A":

- If the spark jumps = the coil functions correctly, so if the system malfunctions, it is due to the earth microswitch or relative cable [[↔ 6.7.B](#)];
- if the spark does not jump = the coil is faulty and must be replaced [[↔ 6.6.C](#)].

20 Remount the conveyor (10).

21 Remount the tank [[↔ 6.1.A](#)].

22 Remove the starting system [[↔ 6.2.A](#)].

### C) Replacing the coil

31 Remove the starting system [[↔ 6.2.A](#)].

32 Remove the tank [[↔ 6.1.A](#)].

33 Remove the conveyor (10).

34 Disconnect the faston of the earth cable (11).

35 Unscrew the screw (14) and stud bolt (15) and remove the coil (12).

36 Fit the new coil and adjust the air gap as described in steps 14 - 15 of the procedure described in point "B".

37 Connect the faston of the earth cable (11).

38 Remount the conveyor (10).

39 Remount the tank [[↔ 6.1.A](#)].

40 Remount the starting system [[↔ 6.2.A](#)].

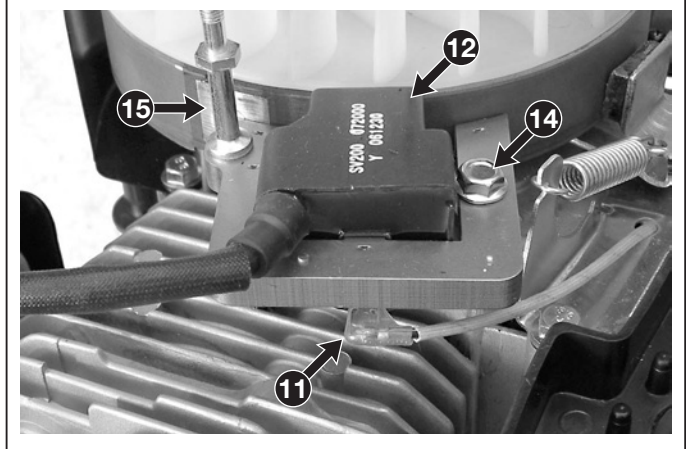
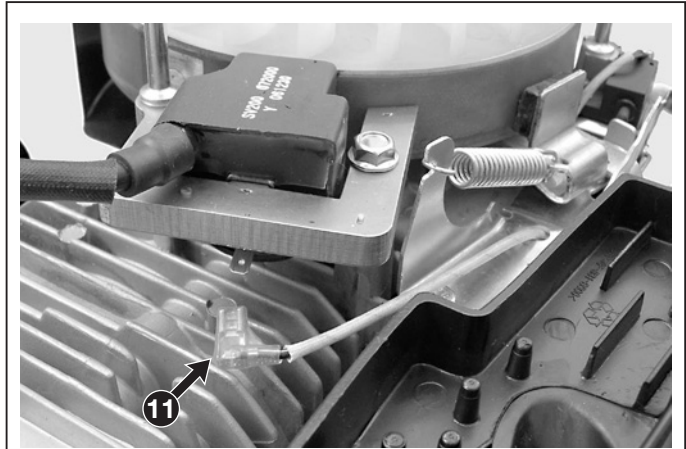

### Tightening torques

- 1 Spark plug tightening torque ..... 16-18 Nm
- 14 Coil fixing screw ..... 8-10 Nm
- 15 Coil fixing stud bolt ..... 8-10 Nm

### Technical information

- Type of spark plug ..... RN9YC (Champion) or equivalent
- Distance between electrodes ..... 0.6-0.8 mm
- Coil/flywheel air gap ..... 0.25-0.40 mm

### Special equipment

- 3 Tester for spark test

6.7.1	from 2007 to
<b>TURNING OFF AND STOPPING THE ENGINE</b>	page 1 / 3

## 6.7 TURNING OFF AND STOPPING THE ENGINE

### GENERAL INFORMATION

The engine is turned off and stopped by releasing a lever on the lawnmower. The cable acts on a lever which simultaneously activates a microswitch that sends the coil to earth as well as a brake which acts on the flywheel.

The brake must be able to stop the engine within 3 seconds after it is turned off.

The system for turning off and stopping the engine can malfunction in the following ways:

- the engine does not start:
  - = brake cable broken or disconnected [↔ 6.7.A];
  - = faulty switch [↔ 6.7.B];
  - = earth cable has deteriorated.
- the engine does not turn off:
  - = brake cable bent or jammed [↔ 6.7.A];
  - = faulty switch or disconnection [↔ 6.7.B].
- the engine does not stop within 3 seconds after it is turned off:
  - = clutch lining has come away [↔ 6.7.C].

If the microswitch malfunctions or if the brake lining has come away, replace the entire assembly which is mounted on a supporting bracket.

For access to the system for turning off and stopping the engine, remove the upper conveyor.

### SERVICING PROCEDURES

**N.B.** - The following must be removed and subsequently reassembled to perform any intervention on the engine switch-off and stopping group:

- the starting system [↔ 6.2.A];
- the tank [↔ 6.1.A];
- the conveyor.

#### A) Checking the control cable

- 1 Check that the sheath (1) is not bent, that the wire (2) is securely connected to both the lawnmower lever and the lever (3) on the engine and that the terminal (4) is correctly fastened to the support (5).

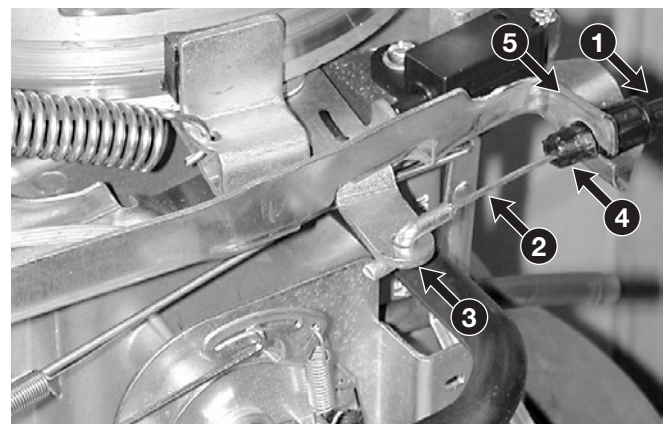
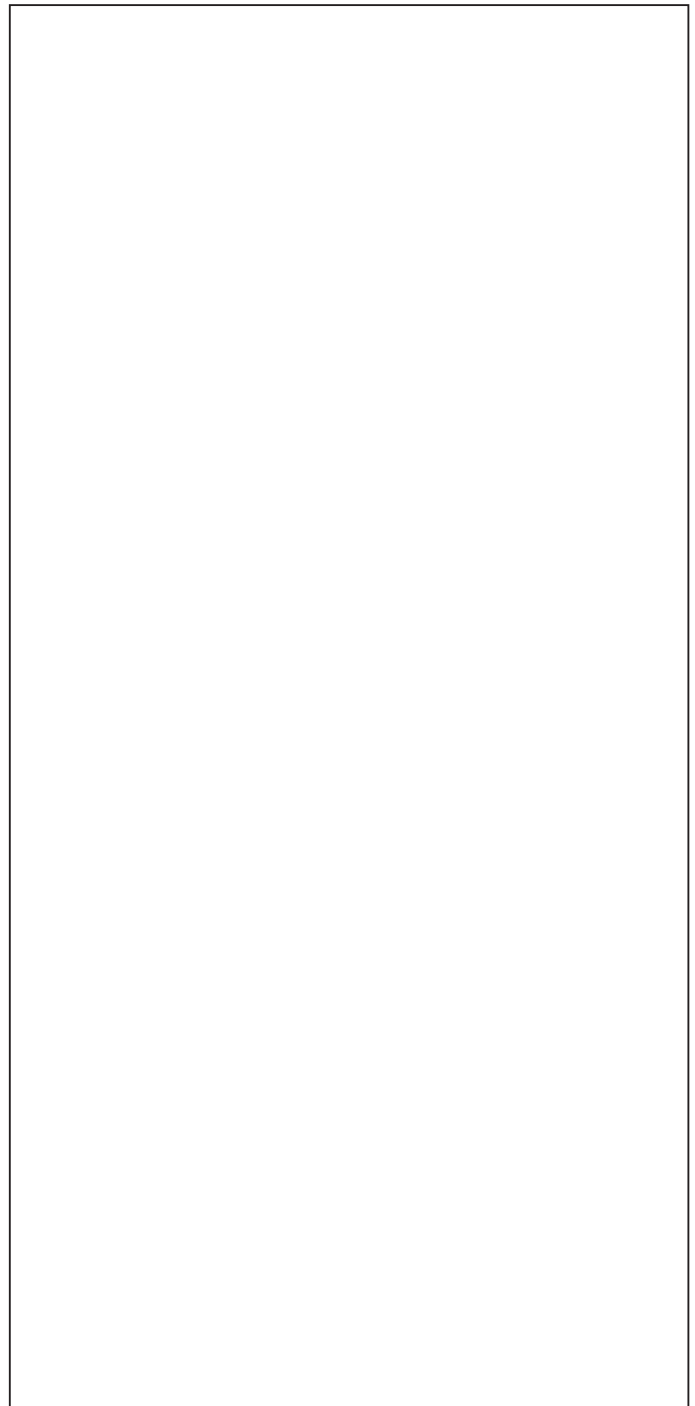

<p>6.7.1 <b>TURNING OFF AND STOPPING THE ENGINE</b></p>	<p>from 2007 to page 2 / 3</p>
---	------------------------------------

- 2 Check that the wire (2) runs freely inside the sheath (1) when you move the lever.
- 3 Check that the end of the wire (2) is slightly loose when you release the lawnmower lever.

### B) Checking the ignition off microswitch

- 11 Disconnect the faston (11) from the coil.
- 12 Using an Ohmmeter tester, make contact with the prods on terminals "1-COM" of the microswitch (12) and engine earth connection; the instrument should read:
  - ∞ = microswitch pressed
  - 0 = microswitch free
 Otherwise, replace the system for turning off and stopping the engine [↔ 6.7.D].

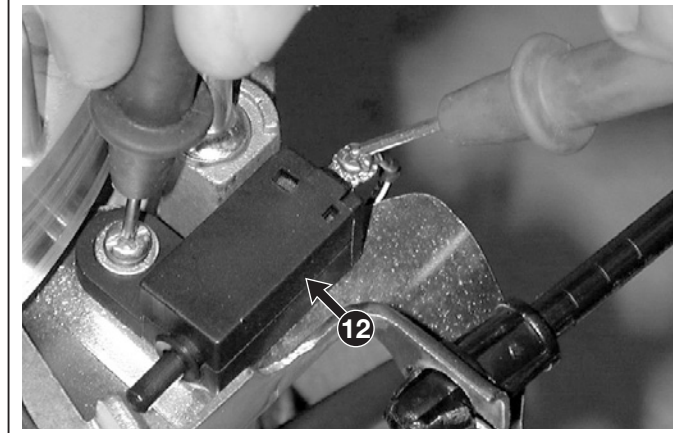

### C) Checking the brake

- 21 Check that the clutch lining (13) is at least 2 mm thick at the thinnest point.
- 22 Make sure that the control lever (14) moves freely and remove any remains of grass and mud.
- 23 Reconnect the petrol pipe and start the engine. Release the lawnmower lever and check that the engine stops within 3 seconds.
- 24 If it stops after 3 seconds, replace the entire assembly [↔ 6.7.D], because the spring or clutch lining is unable to guarantee the right braking times.

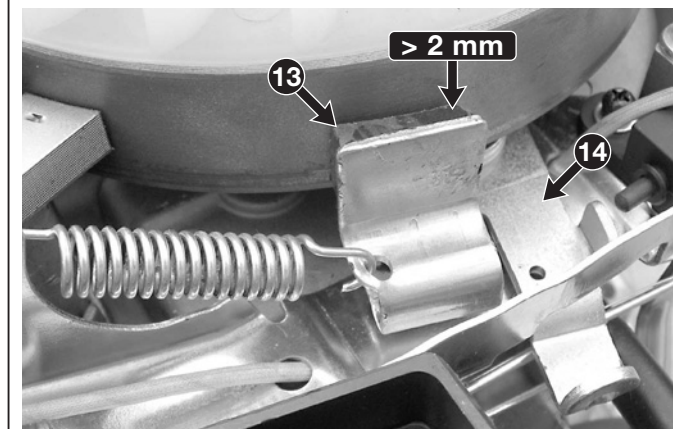

**⚠ WARNING! Never return the lawnmower to your client without checking brake efficiency.**



**D) Replacing the system for turning off and stopping the engine**

- 31 Remove the flywheel [➔ 6.9.E].
- 32 Disconnect the brake wire (21) from the lever (22).
- 33 Disconnect the cable (23) of the microswitch (24).
- 34 Undo the two screws (25) fastening the supporting bracket (26).
- 35 On assembly, follow the steps described in reverse.
- 36 Refit the flywheel [➔ 6.9.E].
- 37 Reconnect the petrol pipe and start the engine. Release the lawnmower lever and check that the engine stops within 3 seconds.

**⚠ WARNING! Never return the lawnmower to your client without checking brake efficiency.**

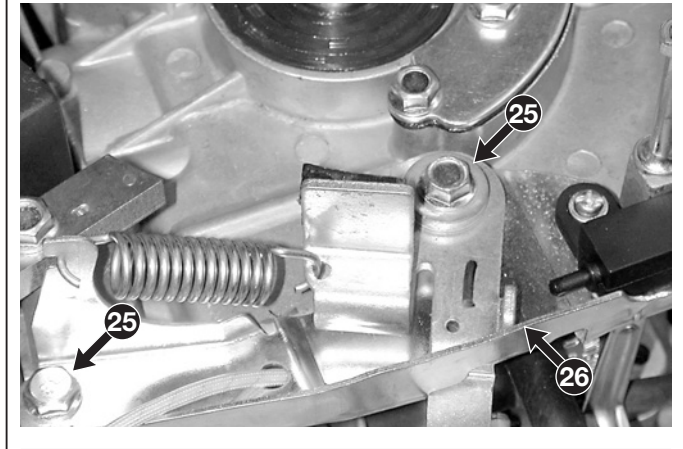
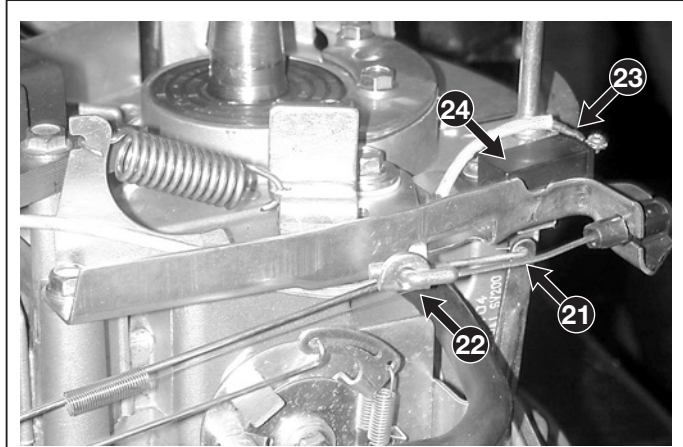

**Tightening torques**

**25** Brake support fixing screws ..... 8-10 Nm

**Special equipment**

- Universal tester



## 6.8.1 EXHAUST SYSTEM



from 2007 to  
page 1 / 1

### 6.8 EXHAUST SYSTEM

#### GENERAL INFORMATION

The exhaust system consists of a muffler installed on the cylinder together with a gasket, a spacer and a heatproof baffle.

A malfunctioning exhaust system may lead to a loss in power or excess noise. However, the muffler is a preassembled part which cannot and must not be disassembled or repaired but only replaced.

#### SERVICING PROCEDURES

##### A) Removing and replacing the muffler

- 1 Remove the two nuts (1) that fix the guard (2 or 2a) and the muffler (3).
- 2 Take out the muffler (3) and the heatproof baffle (4).
- 3 On assembly:
  - thoroughly clean the cylinder contact surface, removing all deposits or fragments on the heatproof baffle;
  - always replace damaged mufflers;
  - always replace the heatproof baffle (4) if it is broken or cracked;
  - tighten the two nuts (1) to the specified levels.

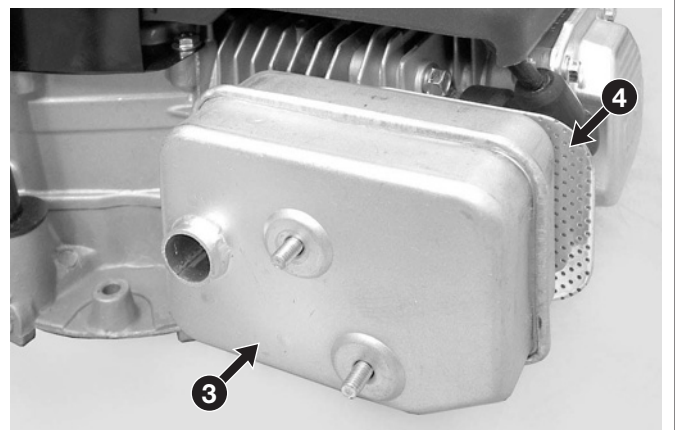
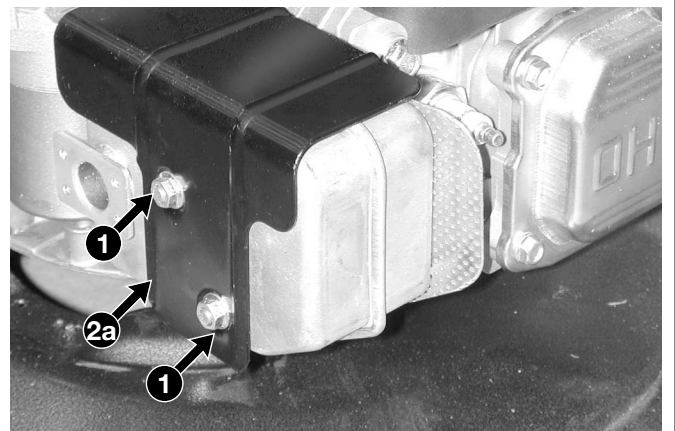
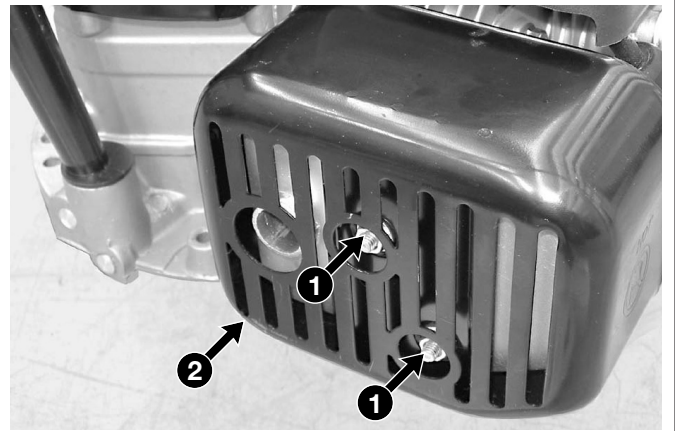

#### Tightening torques

- |                      |         |
|----------------------|---------|
| 1 Muffler nuts ..... | 8-10 Nm |
|----------------------|---------|

6.9.1 <b>ENGINE BLOCK – External operations</b>	from 2007 to page 1 / 7
--	----------------------------

## 6.9 ENGINE BLOCK – External operations

### GENERAL INFORMATION

*This chapter covers the checking, adjustment and replacement operations of components that do not require the engine being removed from the lawnmower to which it is fitted.*

*Removing the engine from the machine and the dismantling and replacement operations for thermal components are described in chapter 6.10.*

### SERVICING PROCEDURES

#### A) Checking the compression

- 1 Remove the cap (1) and take out the spark plug (2).
- 2 Screw the terminal of the compression testing tool (3) into the spark plug hole and connect the supply pipe to a compressed air socket with a pressure of approximately 4.2 Bars (60 psi).
- 3 On opening the air tap (4), the manometer gauge on the engine side should position itself in the green zone and remain there for about 30 seconds. If the gauge falls rapidly it means that the compression is poor.

**NOTE** - Lack of compression could be due to:

- incorrect valve clearance [↔ 6.9.B];
- cylinder head loose or cylinder head gasket worn [↔ 6.9.C].
- lack of seal in the valves [↔ 6.9.D];
- piston rings worn [↔ 6.10.C].

- 4 Remount the spark plug (2) and tighten it to the specified levels.

#### B) Adjusting the valve clearance

**NOTE** - The adjustment must be made with the engine is cold.

- 11 Remove the spark plug and the cover (11) fixed by four screws (12).
- 12 Manually set the piston to the TDC (Top Dead Centre) of the compression stroke so that both valves are closed.

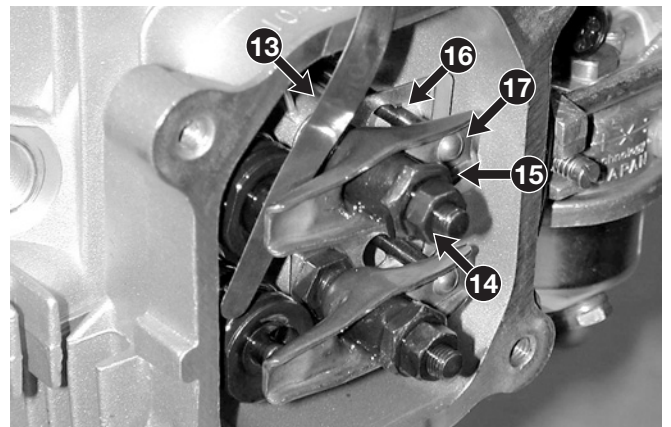
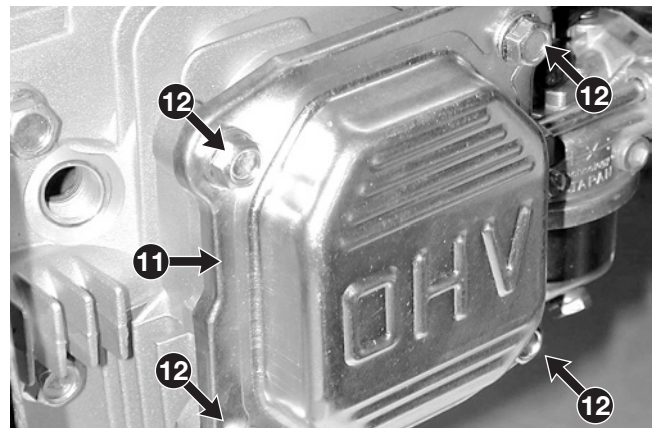
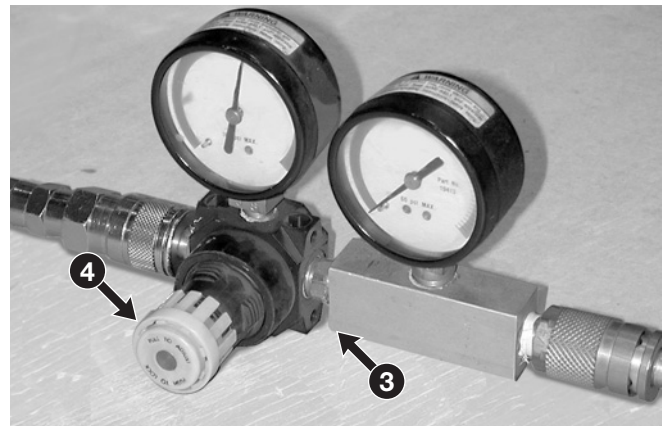
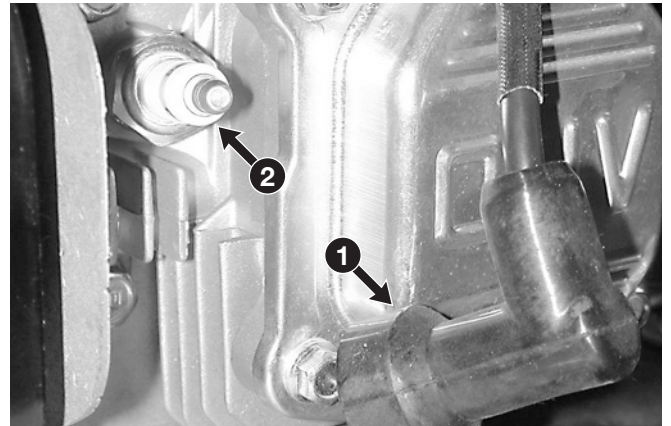



## 6.9.1 ENGINE BLOCK – External operations



from 2007 to

page ◀ 2 / 7 ▶

- 13 Use a 0.10 mm feeler gauge (13) to check the gap between the rocker arm and the tip of the valve stem; the gauge should pass between without forcing and without a further gap.
- 14 The gap is adjusted by slackening off the lock nut (14) and suitably adjusting the register nut (15) until the above condition is reached.
- 15 Following adjustment, check that the pushrods (16) are properly inserted in the rocker arm housings (17) and always fully tighten the nut (14).
- 16 When reassembling check the condition of the gasket (18) under the cover (11) and replace it if it is damaged.

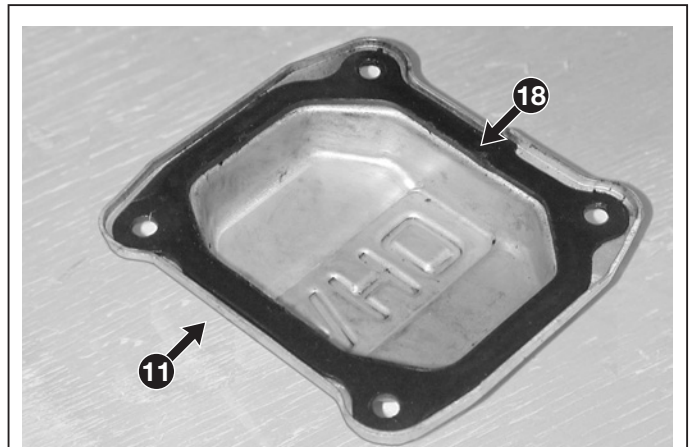

### C) Dismantling and cleaning the cylinder head

- 21 Remove the starting system [↔ [6.2.A](#)].
- 22 Remove the tank [↔ [6.1.A](#)].
- 23 Remove the conveyor (20).
- 24 Remove the carburettor [↔ [6.4.A](#)].
- 25 Remove the exhaust muffler [↔ [6.8.A](#)].
- 26 Remove the spark plug and the cover (21) fixed by four screws (22).
- 27 Unscrew the four screws (23) that fix the cylinder head (24).
- 28 Remove the gasket (25) and clean the cylinder head (26) and cylinder surfaces (24).
- 29 Carefully clean the inside of the combustion chamber (27) and remove possible deposits from the valve seats.

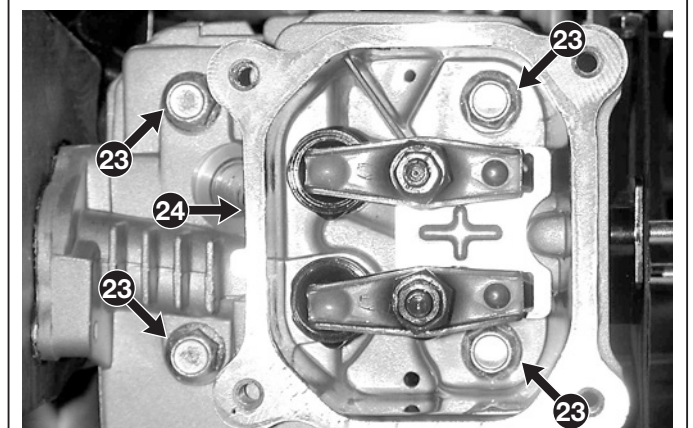
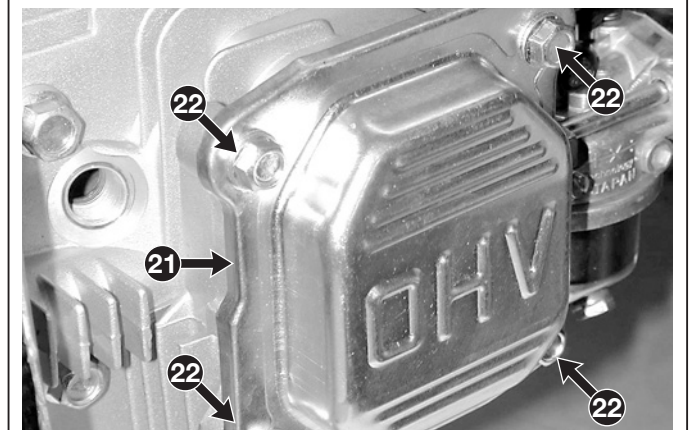

<p>6.9.1 <b>ENGINE BLOCK – External operations</b></p>	<p>from 2007 to page 3 / 7</p>
--	------------------------------------

- 30 Turn the flywheel manually to move the piston and clean inside the cylinder (26).
- 31 When mounting:
  - the gasket (25) must always be replaced;
  - refit the cylinder head (24) first screwing in the four screws (23) without fully tightening, then tighten them to the given torque values, using a cross-over sequence.
- 32 Refit the exhaust muffler [↔ 6.8.A].
- 33 Remount the carburettor [↔ 6.4.A].
- 34 Remount the conveyor (20).
- 35 Remount the tank [↔ 6.1.A].
- 36 Remount the starting system [↔ 6.2.A].

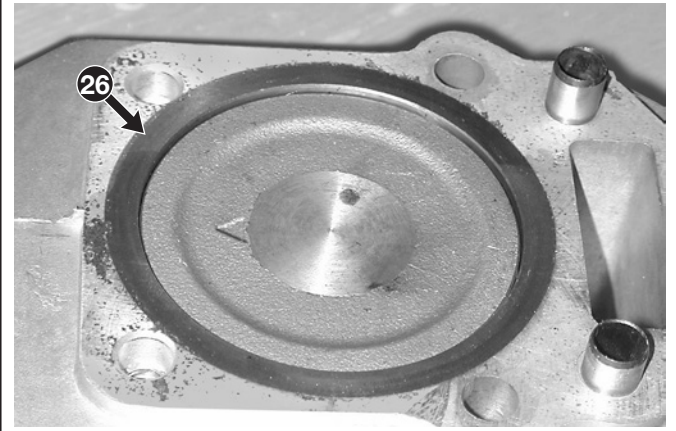
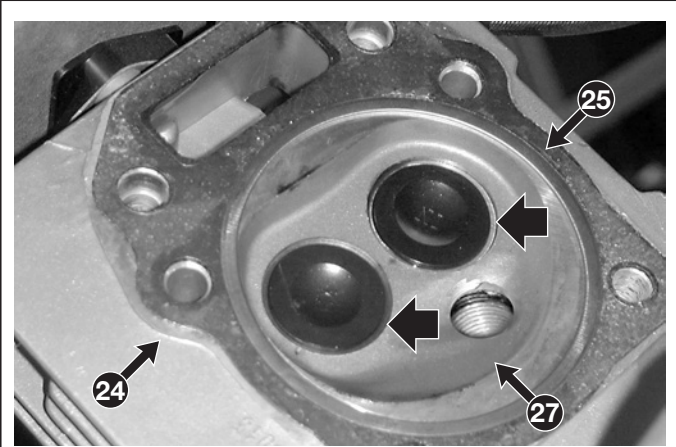

**D) Overhauling the cylinder head and valves**

**NOTE** - These paragraphs describe all the operations for checking and overhauling the cylinder head; it is left to the operator to assess the advisability of performing all the operations described or only part of them, depending on the type of engine problems encountered.

- 41 Dismount the cylinder head [↔ 6.9.C].
- 42 Move the rocker arms (31); press down the spring seal cap (32) and move it sideways to remove from the valve stem (33).

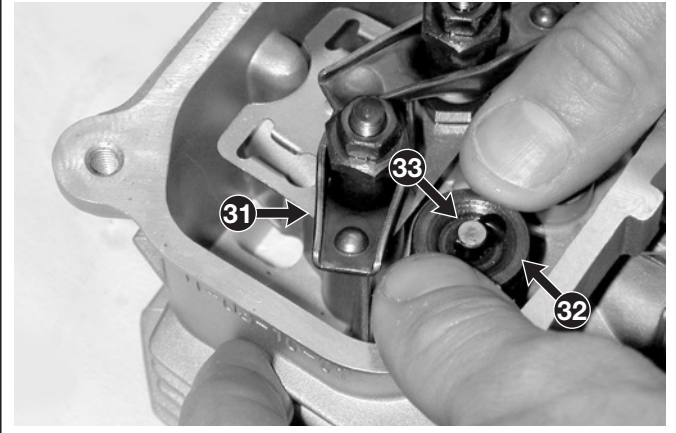

**IMPORTANT** - The inlet and exhaust valves are different from each other and can be identified by the marking «IN» (inlet) and «EX» (exhaust), on the valve head.

- 43 Use an emery cloth to remove all incrustations from the valve head (33) and check the thickness of the rim (A). The valve must be replaced if the rim (A) is less than 0.5 mm or shows signs of burning.
- 44 Check the diameter of stem (B) in several points and replace the valve if it is less than the following, even if only in one point:
  - 5.4 mm (inlet - IN)
  - 5.4 mm (exhaust - EX)

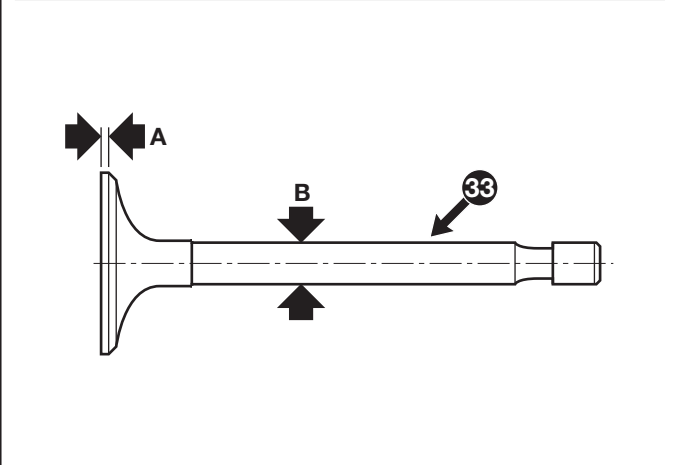

<p>6.9.1 <b>ENGINE BLOCK – External operations</b></p>	<p>from 2007 to page 4 / 7</p>
--	------------------------------------

**NOTE** - The valve seats must be ground by hand, using a special grinding tool with an angle of 45°.

45 Insert the pin (34) in the cylinder head valve guide and then the grinding tool (35).

**NOTE** - Grinding must be done taking care to remove as little material as possible.

46 Use a caliper gauge to check the depth of the valve seat (C), which must be between 0.8 and 1.5 mm inclusive; the cylinder head must be replaced if a greater value is measured.

47 Apply abrasive paste for grinding around the rim of the valve head (33) and then insert the valve into its seat.

48 Use the special manually operated tool (36) to grind the seat and rim of the valve.

49 Remove the valve and use clean petrol to carefully clean all traces of paste or metal residues from the valve seat and rim.

50 Check the free length of the spring (37) and replace the spring if it is less than 32,5 mm.

51 When mounting:  
– carefully clean the valve guides and housings of any foreign body;

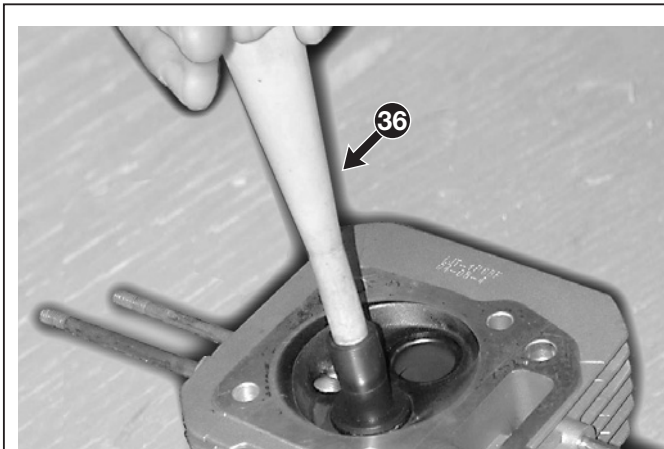
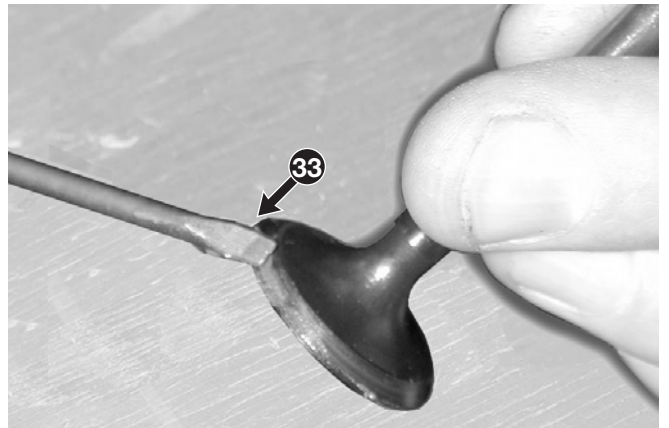
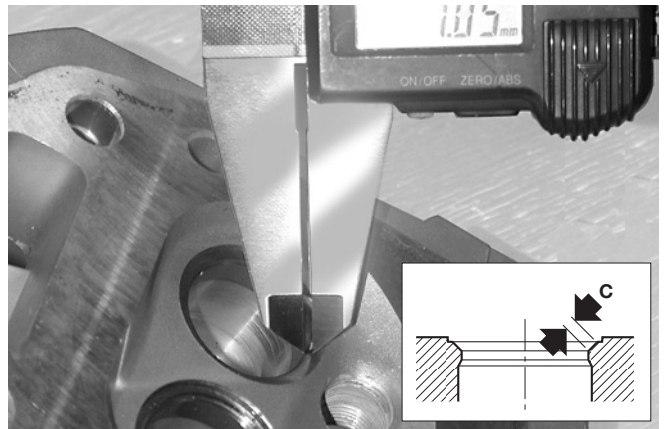
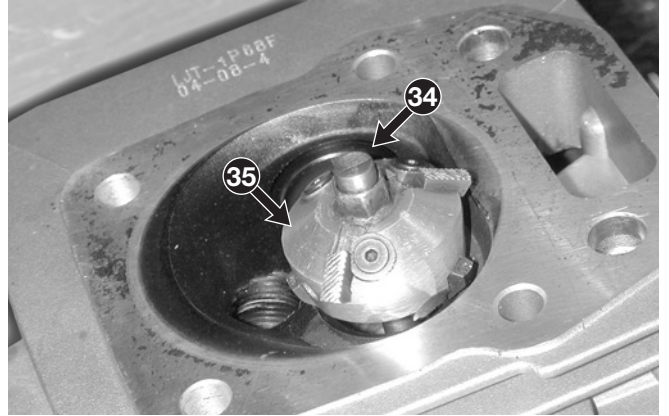

<p>6.9.1 <b>ENGINE BLOCK – External operations</b></p>	<p>from 2007 to page 5 / 7</p>
--	------------------------------------

- apply a film of oil on the valve stems before inserting them in their respective housings;
- ensure the correct position of the inlet valve and the exhaust valve, marked, respectively, with «IN» and «EX» on the valve head.

52 Remount the cylinder head [↔ [6.9.C](#)].

53 The valve clearances must be checked whenever the cylinder head is removed and refitted [↔ [6.9.B](#)].

**E) Dismantling and replacing the magneto flywheel**

61 Remove the starting system [↔ [6.2.A](#)].

62 Remove the tank [↔ [6.1.A](#)].

63 Remove the conveyor (20).

**NOTE** - If no tools are available for locking rotation of the engine shaft, a striker gun must be used for removing and refitting the flywheel.

64 Use a striker gun to unscrew the nut (41) locking the magneto flywheel (42).

65 Screw the nut (41) a few turns onto the engine shaft so that the puller is not working directly on the shaft.

66 Remove the magneto flywheel (42) using a puller (43) suitable for the purpose.

67 On assembly check the condition of the spline key (44) and replace it if damaged; screw on the nut (41) to the specified torque using a striker gun.

68 Remount the conveyor (20).

35 Remount the tank [↔ [6.1.A](#)].

36 Remount the starting system [↔ [6.2.A](#)].

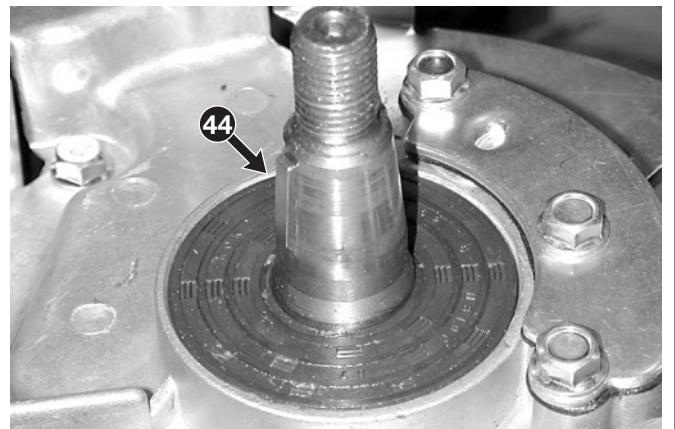
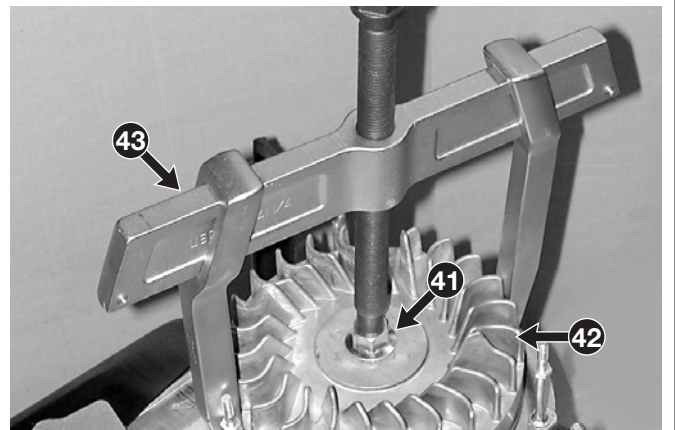
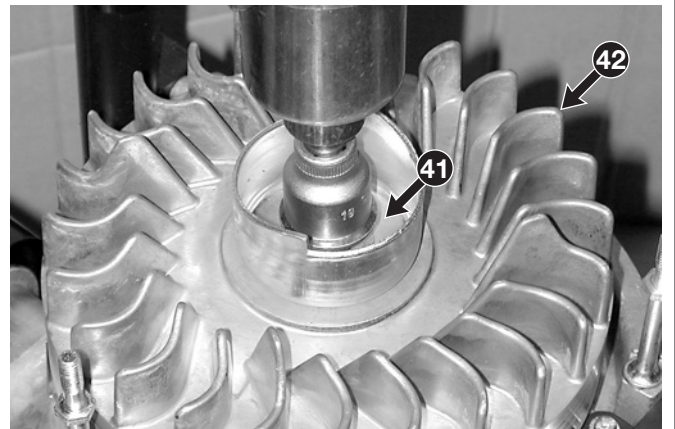
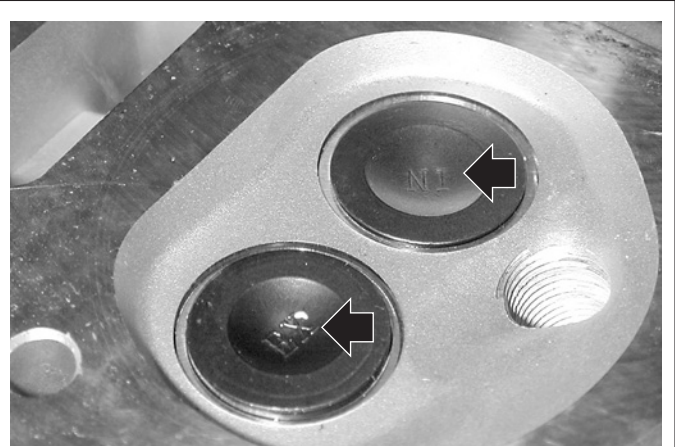

<p>6.9.1 <b>ENGINE BLOCK – External operations</b></p>	<p>from 2007 to page ◀ 6 / 7 ▶</p>
--	--

**F) Checking the oil breather**

- 71 Remove the magneto flywheel [↪ [6.9.E](#)].
- 72 Unscrew the three screws (51) fixing the closing plate (52).
- 73 Check that the valve (53) is not broken or damaged and that it can move freely in its housing.
- 74 Refit the plate (52) with the relative gasket.
- 75 Refit the magneto flywheel [↪ [6.9.E](#)].

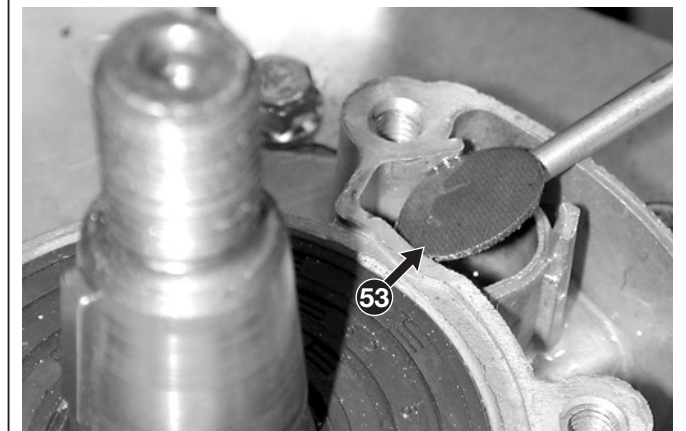
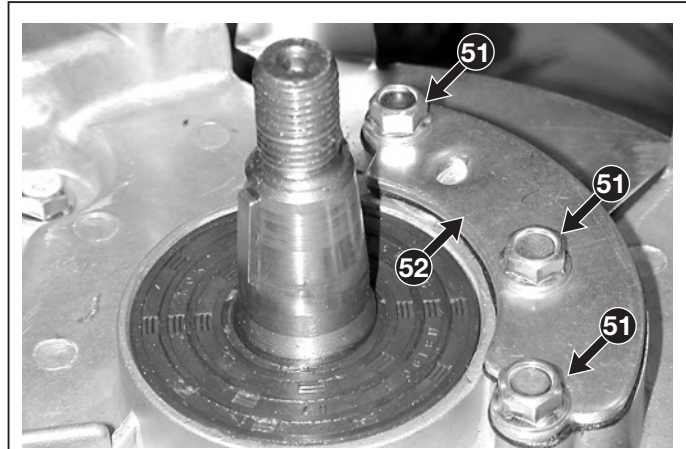

**G) Replacing the upper compression ring of the engine shaft (flywheel side)**

- 81 Remove the magneto flywheel [↪ [6.9.E](#)].
- 82 Take out the spline key (61).
- 83 Use a thin screwdriver inserted under the sealing lip to extract the oil seal ring (62).
- 84 The new ring (63) must be inserted with the help of a pipe (64) with a diameter of approximately 50-55 mm, taking care not to damage the sealing lip.
- 85 Refit the magneto flywheel [↪ [6.9.E](#)].

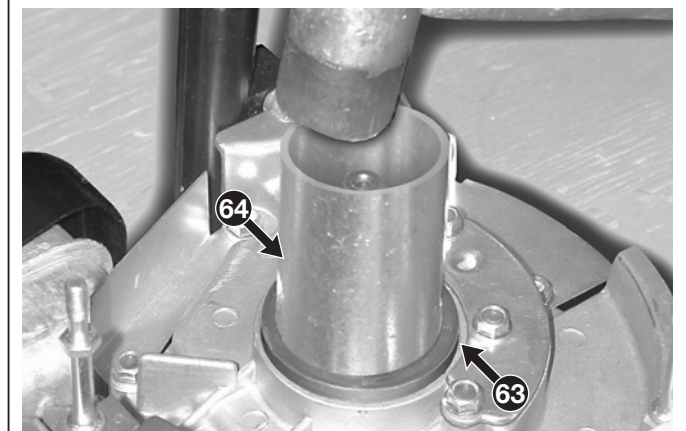
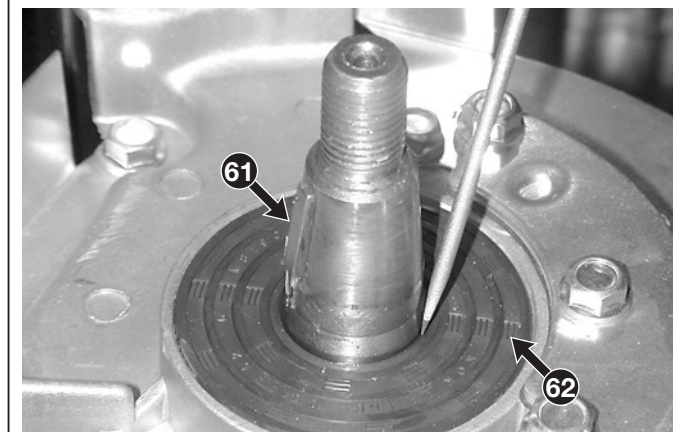



**H) Replacing the lower compression ring of the engine shaft (sump side)**

**NOTE** - This operation must be performed by lifting the lawnmower from the front after having drained all the oil from the sump and the fuel from the tank.

- 91 Remove the blade (71) and hub (72).
- 92 Take out the spline key (73).
- 93 Use a thin screwdriver inserted under the sealing lip to extract the oil seal ring (74).
- 94 Make a paper tube (75) around the shaft to protect the sealing lip and insert the new ring (76) so that it enters its housing.
- 95 Complete the insertion with the help of a pipe (77) of a diameter of approximately 30-35 mm.

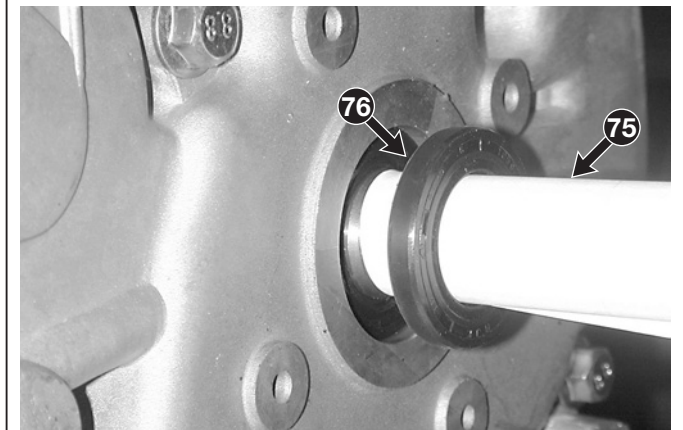
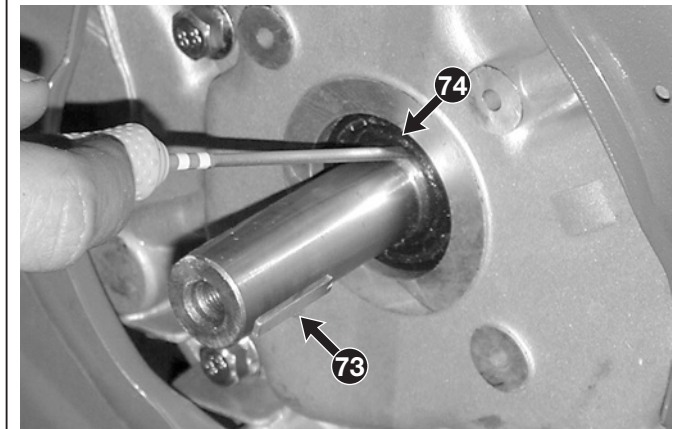

**Tightening torques**

2	Spark plug tightening torque .....	18-22 Nm
12-22	Valve cover fixing screws .....	8-10 Nm
23	Cylinder head screws .....	22-25 Nm
41	Magneto flywheel fixing nut .....	45-50 Nm
51	Breather plate fixing screws .....	8-10 Nm

**Technical information**

Inlet valve clearance .....	0.08-0.10 mm
Exhaust valve clearance .....	0.08-0.10 mm
Minimum inlet valve stem diameter .....	5.4 mm
Minimum exhaust valve stem diameter .....	5.4 mm
Minimum inlet valve head rim thickness .....	0.5 mm
Minimum exhaust valve head rim thickness .....	0.8 mm
Valve seat depth .....	0.8-1.25 mm
Minimum valve spring length .....	32.5 mm

**Special equipment**

- 3 Compression testing tool
- 35 Valve seat grinding tool
- 36 Valve grinder

6.10.1	from 2007 to
<b>ENGINE BLOCK – Overhauling internal parts</b>	page 1 / 7

## 6.10 ENGINE BLOCK – Overhauling internal parts

### GENERAL INFORMATION

All operations for dismantling and replacing internal engine components require the engine to be removed from the lawnmower.

### SERVICING PROCEDURES

#### A) Removing the engine and opening the cover

- 1 Empty the tank of fuel [➔ 6.1.A].
- 2 Disconnect the throttle cable (1) and the engine brake cable (2).
- 3 Dismount the cutting assembly and undo the (3) screws which are accessible from the bottom of the lawnmower.
- 4 Hold the engine in points with a firm grip, remembering that it weighs approx.13 kg.
- 5 Place the engine on a stand able to ensure its stability, unscrew the oil drain plug (4) and collect all the oil contained in the sump.
- 6 Overturn the engine so that the protuberance of the shaft is at the top and place the engine on a stand able to ensure the required stability for performing all the following operations.
- 7 Remove the sump (5) fixed by six screws (6).
- 8 On assembly, follow the steps described in reverse and:
  - always replace the gasket (7) between cover and sump;

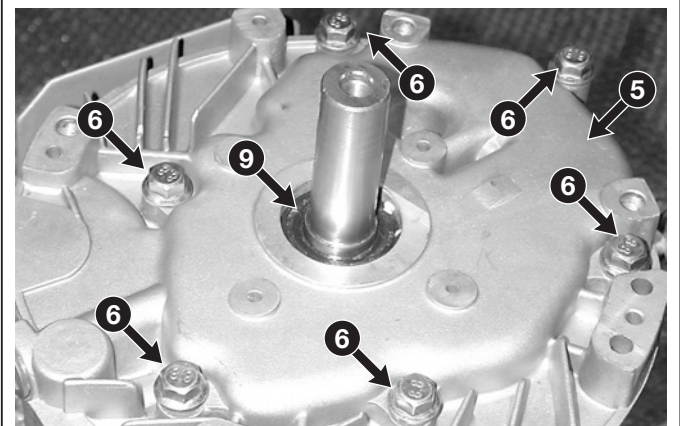
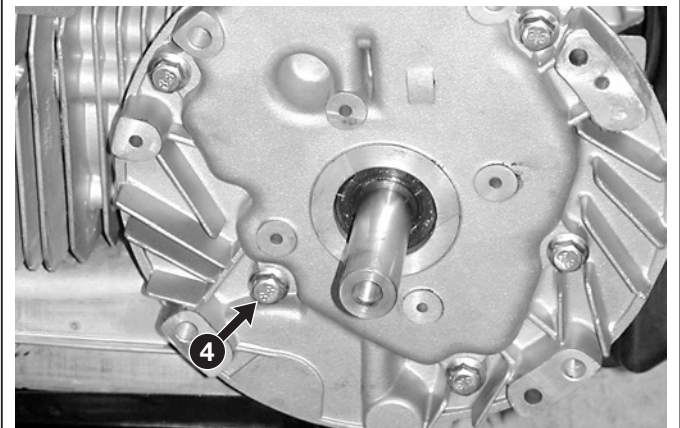
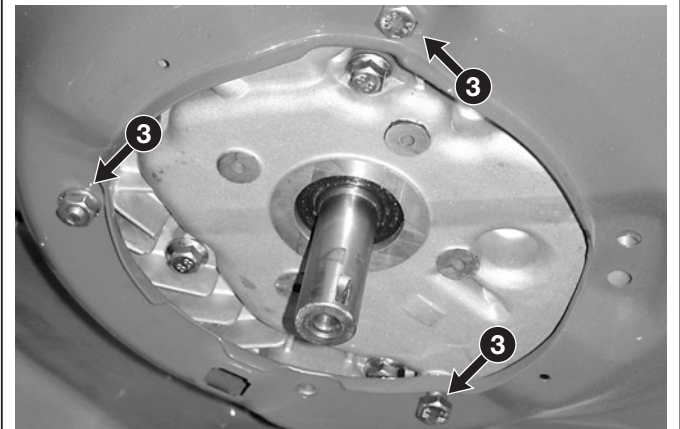
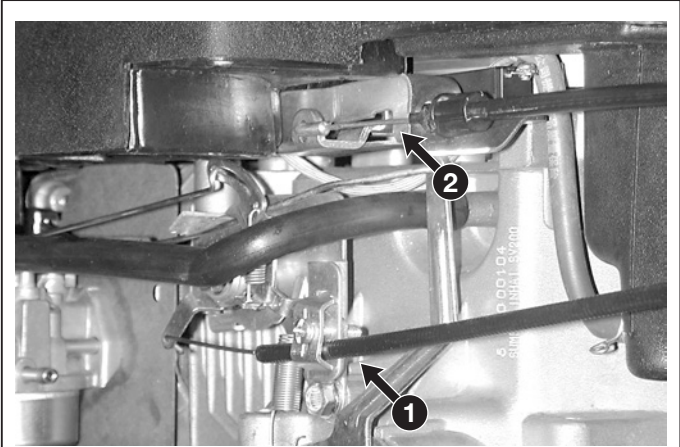

<p>6.10.1 <b>ENGINE BLOCK – Overhauling internal parts</b></p>	<p>from 2007 to page 2 / 7</p>
--	------------------------------------

- ensure that the two centring pins (8) are correctly inserted;
- always replace the compression ring (9) from the sump side [↔ 6.9.H].
- ensure that the governor lever (10) is facing upwards;
- ensure that the oil plug (4) is properly screwed in and fill the cover.

9 After installing the engine on the machine:

- check that the throttle cable is correctly adjusted [↔ 6.5.A].
-  check the efficiency of the engine brake [↔ 6.7.C]

10 Following reassembly it is advisable to check the engine's peak rpm [↔ 6.5.B].

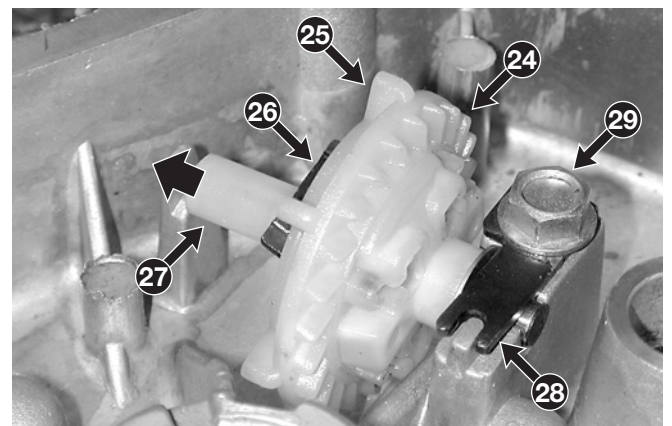
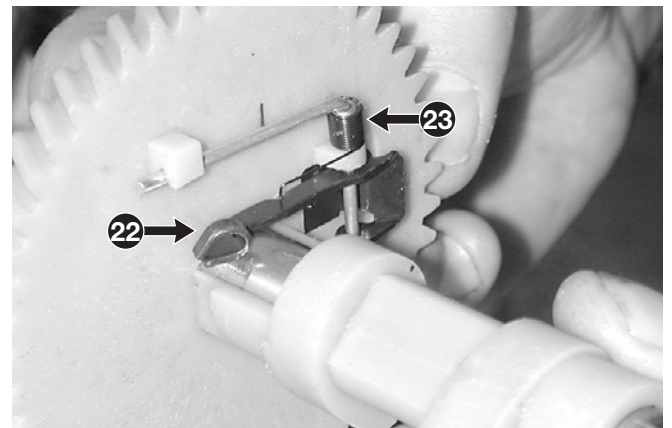
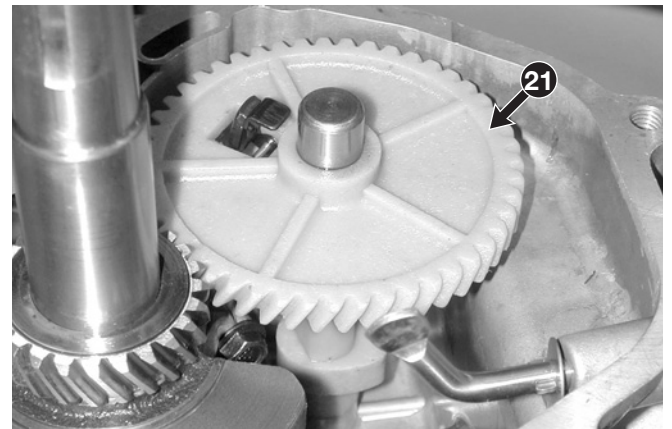
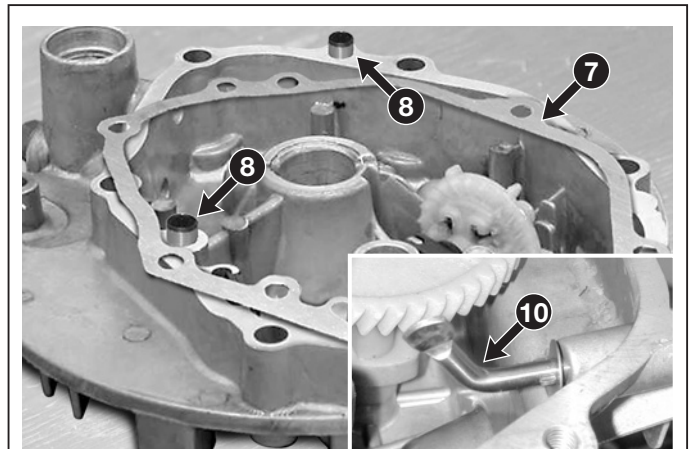

## B) Dismantling and checking the camshaft and counterweight governor

21 Remove the engine from the machine and open the cover [↔ 6.10.A].

22 Remove the camshaft (21).

23 Check the regular movement of the pressure reducer (22) and the efficiency of the spring (23); the whole group must always be replaced in the case of breakage or irregular operation of the pressure reducer.

24 Check that the counterweight governor (24) has no broken lubrication blades (25).

25 Turn the governor's gears quickly and check that the counterweights (26) expand correctly, causing the pin (27) to be moved axially.

26 In the case of breakage or irregular operation of the counterweights the whole group, fixed by a plate (28) and a screw (29) must be replaced.

<p>6.10.1 <b>ENGINE BLOCK – Overhauling internal parts</b></p>	<p>from 2007 to page 3 / 7</p>
--	------------------------------------

27 When assembling the new group, care must be taken over the correct positioning of one scraper washer (30) under the sliding pin (27) and the other (31) on the opposite side.

28 Refit the governor to the pan, being careful to insert the milling of the spindle (32) into the protuberance (33) of the support.

29 Before fitting the camshaft ensure that the two tappets (34) are correctly housed in their seats.

30 When refitting the camshaft, maximum care must be taken to match up the two references (35) and (36) punched on the gears, so as to ensure correct distribution phasing.

31 Reclose the cover and refit the engine to the machine [↗ [6.10.A](#)].

**C) Dismantling and checking the piston, piston rings, connecting rod and engine shaft**

**NOTE** - These paragraphs describe all the operations for checking and overhauling the thermal components of the engine; it is left to the operator to assess the advisability of performing all the operations described or only part of them, depending on the type of engine problems encountered.

41 Remove the engine from the machine [↗ [6.10.A](#)].

42 Dismantle the flywheel [↗ [6.9.E](#)].

43 Remove the cylinder head [↗ [6.9.C](#)].

44 Open the cover [↗ [6.10.A](#)].

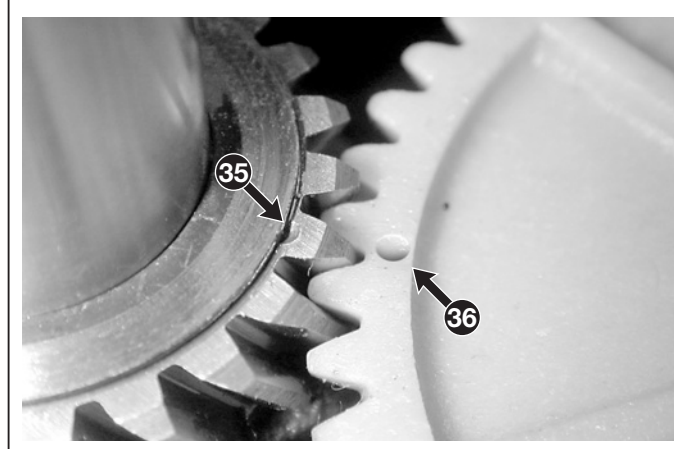
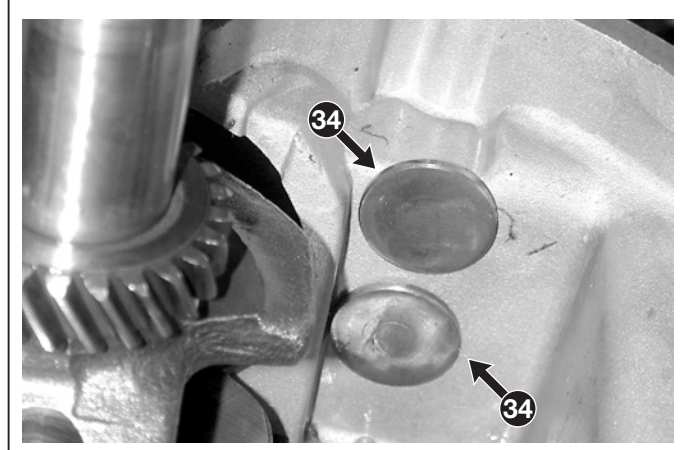
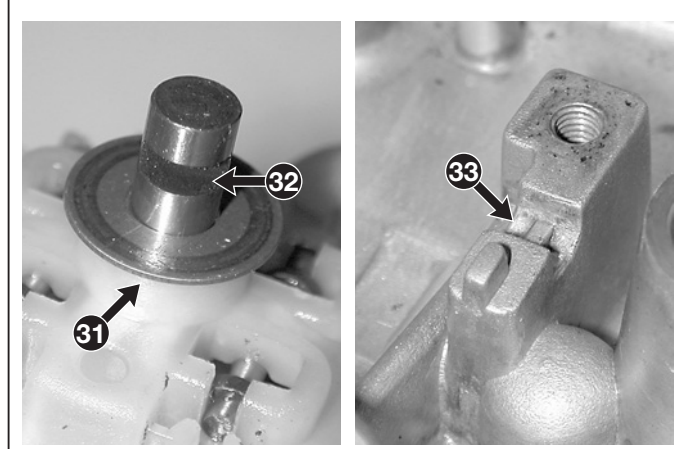
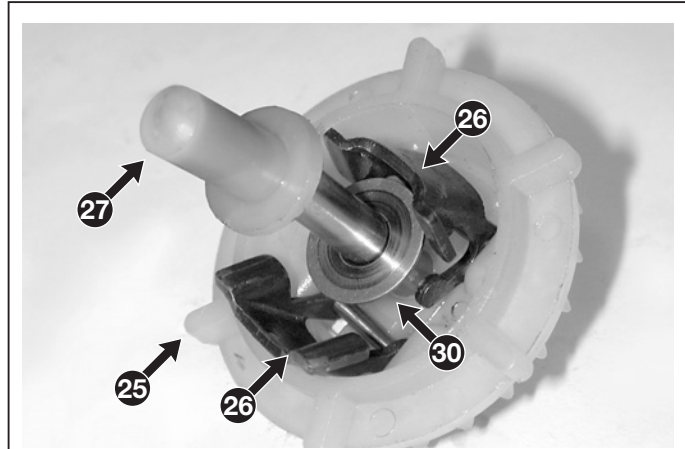

- 45 Remove the camshaft [[↩ 6.10.B](#)].
  - 46 Dismantle the connecting rod (42) cap (41), fixed with two screws (43).
  - 47 Push the connecting rod (42) so as to cause the piston (44) to come out of the cylinder (45).
  - 48 Use the special expanding tool (46) to remove the two compression rings and the oil scraper ring from the piston (44).
  - 49 Carefully remove all carbon deposits from the compression rings, the inside of the cylinder and the piston head.
  - 50 To check the wear in the compression rings, insert them one at a time into the cylinder (45) by about 10-15 mm and measure the gap between the two ends with a feeler gauge (47); the rings must be replaced if the gap is more than 0.85 mm.
- NOTE** - If a gap of more than 0.6 mm is measured with new rings it means that the cylinder is worn beyond the acceptable limits and must be replaced. The cylinder must be replaced if it shows striping due to a seizure.
- 51 Use a section of an old ring (48) to carefully clean the inside of the piston (44) ring housings, ensuring that the oil passage holes are not blocked.

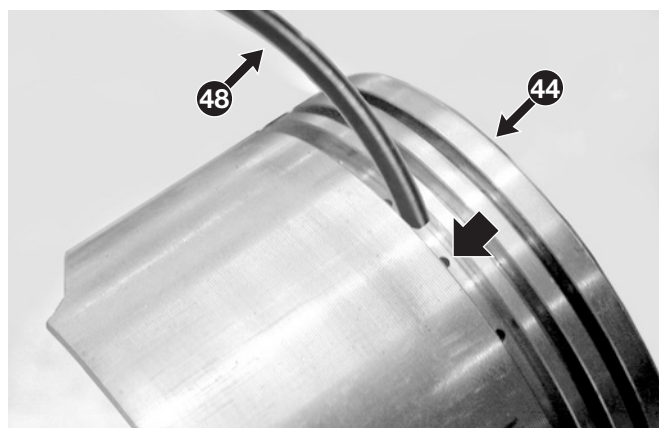
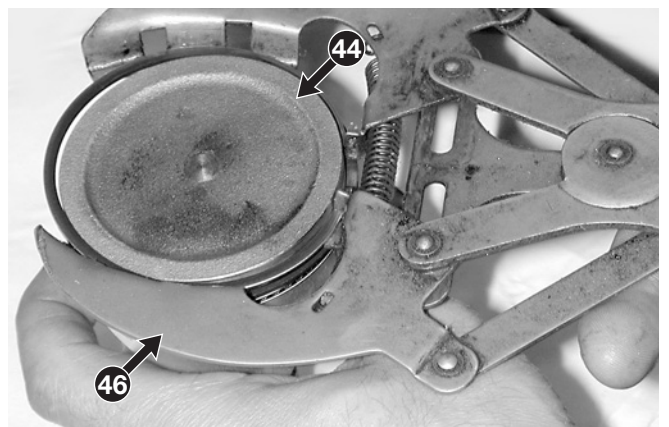
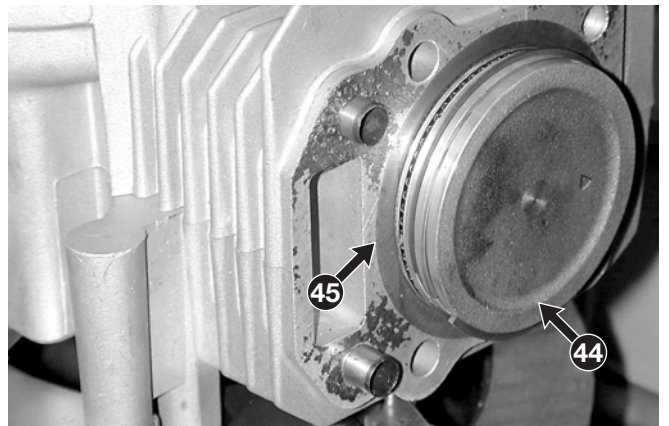
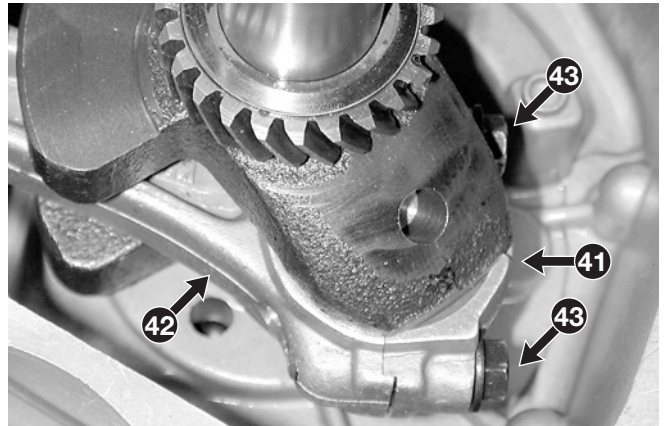

<p>6.10.1 <b>ENGINE BLOCK – Overhauling internal parts</b></p>	<p>from 2007 to page 5 / 7</p>
--	------------------------------------

52 To check the wear in the piston ring housings, fit a new ring and measure the residual space with a feeler gauge (49). The piston must be replaced if it is greater than 0.1 mm in the two compression ring housings.

53 Use a screwdriver to remove the clamping ring (50) and remove the gudgeon pin (51) from the piston (44).

54 Check the diameter of the gudgeon pin (51) in several places and replace it if it is less than 17.956 mm, even at a single point.

55 Check the diameters of the gudgeon pin housings (A) on the piston (44) and replace the piston if they are more than 18.1 mm, even at a single point.

56 Fit the cap (41) to the connecting rod (42) and check the diameter from the gudgeon pin side and the crank side; replace the connecting rod if the values are greater than:

- B = 18.1 mm on the gudgeon pin side;
- C = 30.15 mm on the crank side.

57 Dismantle the engine shaft (52) and check the diameter of the manifolds on both the flywheel side and the outlet side; replace the shaft if they are less than the following, even in a single case:

- 24.88 mm (flywheel side);
- 24.88 mm (outlet side).

**NOTE** - In the case of seizing, the manifolds can be polished with fine emery cloth, only removing foreign matter and checking that the final size remains within the aforementioned limit.

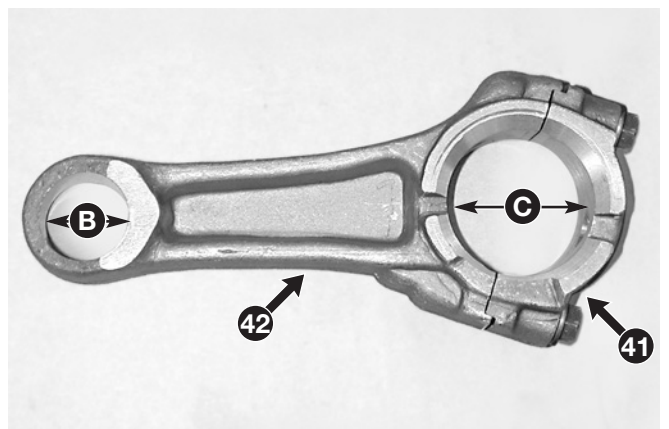
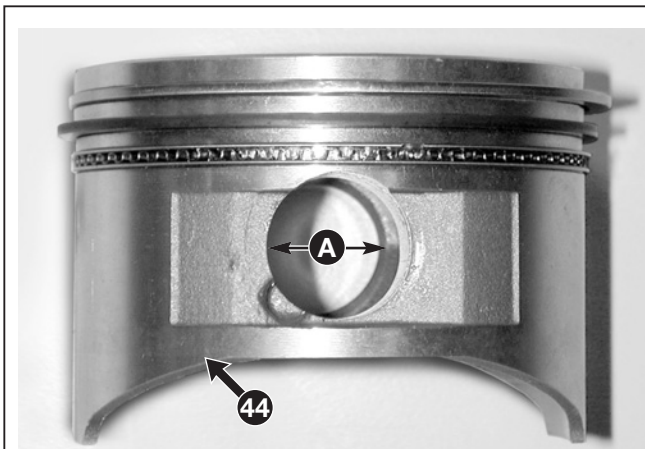
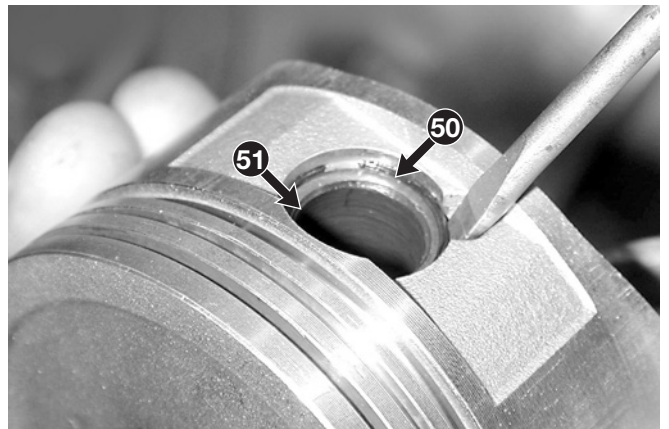

<p>6.10.1 <b>ENGINE BLOCK – Overhauling internal parts</b></p>	<p>from 2007 to page ◀ 6 / 7 ▶</p>
--	--

58 To check the alignment between the manifolds and the protruding part of the shaft, place the engine shaft on two prismatic guides (53) and, with the help of a comparator (59) placed at the end, check the displacement by rotating the shaft. The shaft must be replaced if the displacement exceeds 0.15 mm.

**IMPORTANT** - A bent shaft must never be repaired!

**⚠ WARNING** – A bent shaft causes abnormal vibrations and could be dangerous when the machine is used!

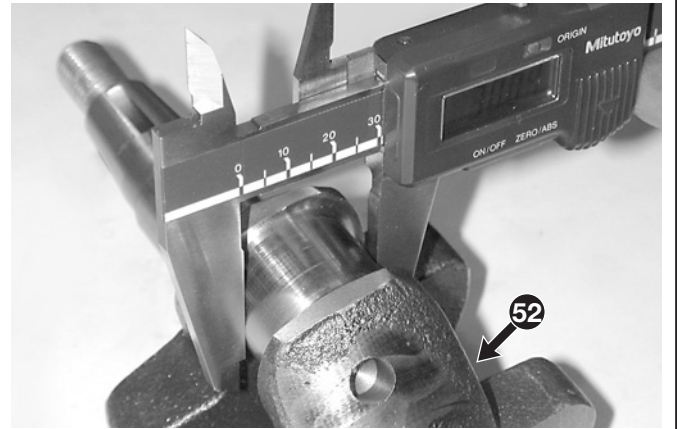

59 To refit the rings to the piston, first fit the three oil scraper rings (55), then the ring with a round edge (56) and finally the ring with a sharp edge (57), being careful over the markings (which must face the piston head) and in arranging the gaps to ensure that they are not aligned with each other.

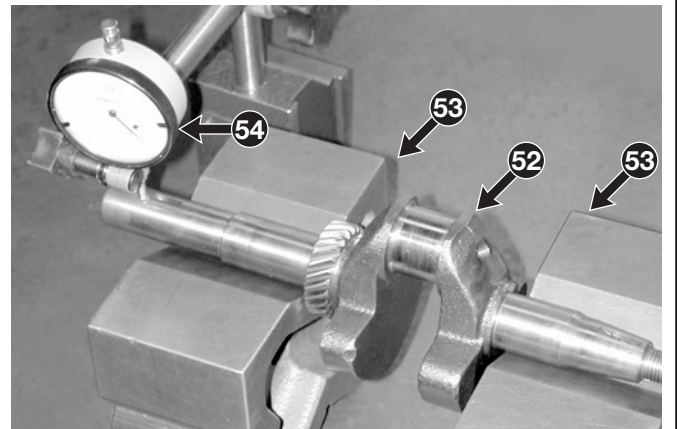

60 Fit the connecting rod (42), gudgeon pin (51) and clamping rings (50) to the piston (44), taking care over the connecting rod marking, which must face the outlet side of the engine shaft, with the piston marking facing the exhaust.

61 Put the piston into the ring compression tool (58).

62 Oil the inside of the piston liberally and insert the piston, with the marking facing the exhaust.

63 Refit the engine shaft (52) taking maximum care to match up the two references (59) and (60) punched on the gears, so as to ensure correct distribution phasing.

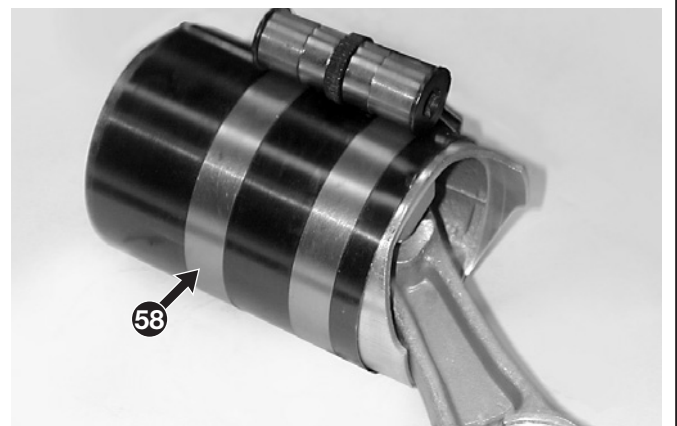
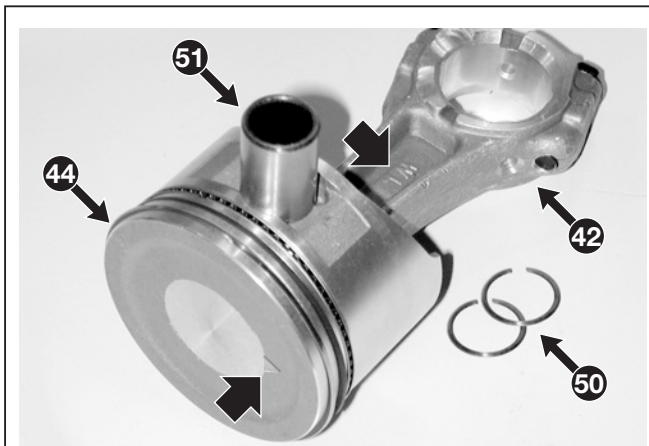
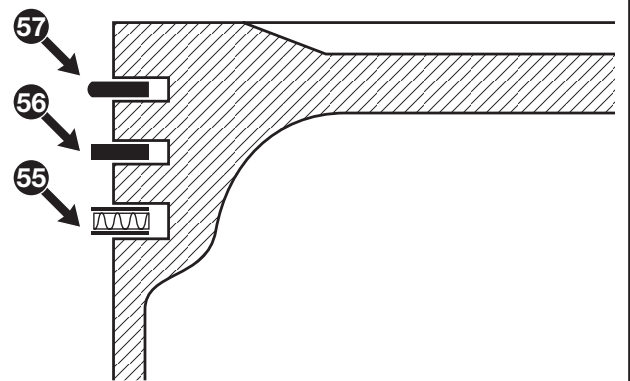

- 64 Assemble the engine shaft (52) and the connecting rod cap (41) with the relative screws (43), taking care not to reverse the cap assembly direction.
- 65 Reclose the cover [↔ 6.10.A].
- 66 Whenever the engine shaft is dismantled and refitted, it is always necessary to:
  - replace the sealing ring on the flywheel side [↔ 6.9.G].
  - replace the sealing ring on the sump side [↔ 6.9.H].
- 67 Remount the cylinder head [↔ 6.9.C].
- 68 Refit the flywheel [↔ 6.9.E].
- 69 Refit the engine to the machine [↔ 6.10.A].

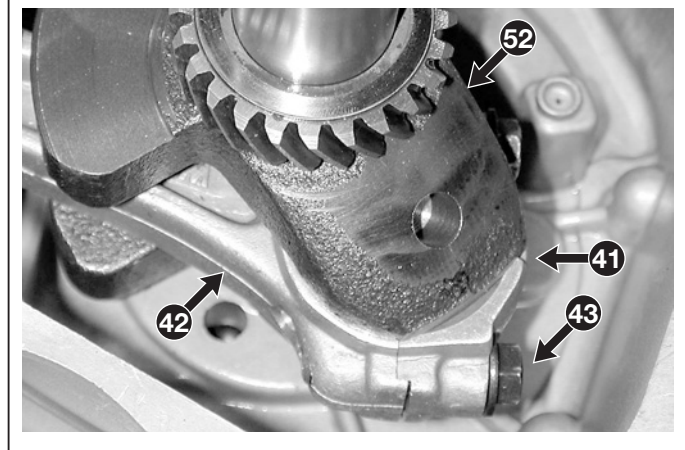
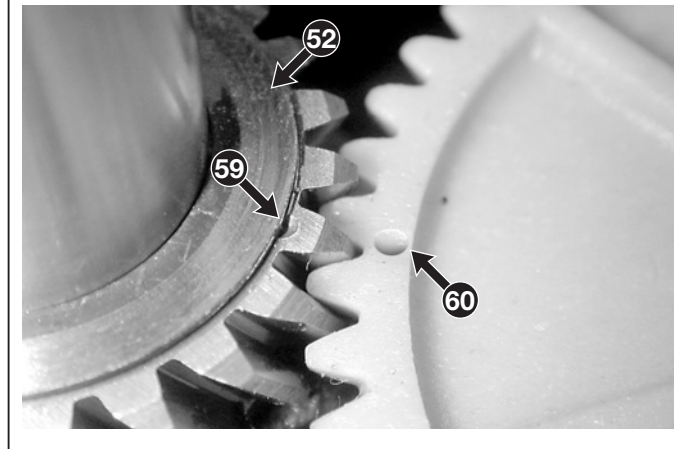
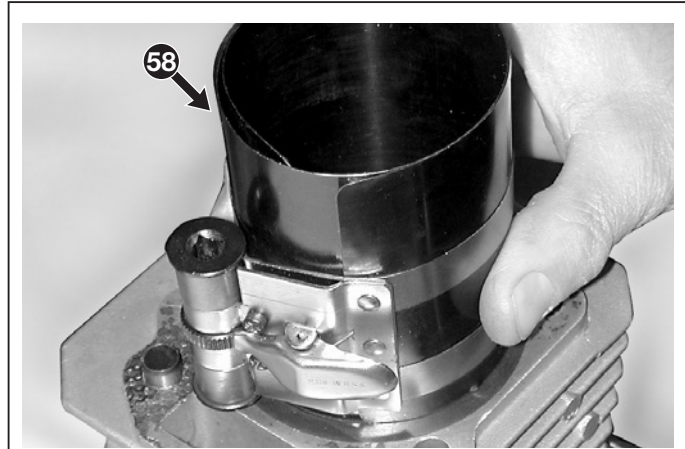

**Tightening torques**

3	Screws for engine fastening .....	20-28 Nm
6	Cover-sump union screws .....	8-10 Nm
29	Counterweight governor fixing screw .....	8-10 Nm
43	Connecting rod fixing screws .....	12-15 Nm

**Technical information**

Oil sump capacity .....	0.65 litres
Maximum segments gap in the cylinder ..	0.85 mm
Max. compression ring axial gap .....	0.1 mm
Minimum gudgeon pin diameter .....	17.95 mm
Max. gudgeon pin housing diameter on piston .....	18.1 mm
Max. connecting rod diameter	
gudgeon pin side.....	18.1 mm
crank side .....	30.15 mm
Minimum engine shaft manifold diameter	
flywheel side .....	24.88
outlet side .....	24.88

**Special equipment**

- 46 Piston ring removal expander
- 58 Piston ring compressing tool



<p>◀</p> <p>◀</p>	<p><b>6.11.0 - ELECTRICAL STARTING SYSTEM AND RECHARGE ALTERNATOR</b></p>	<p>▶</p> <p>▶</p>	<p>from 2007 to</p> <hr/> <p>page ◀ 1 / 4 ▶</p>
-------------------	---	-------------------	---

## 6.11 ELECTRICAL STARTING SYSTEM AND RECHARGE ALTERNATOR

### GENERAL INFORMATION

The electrical starting system consists of a motor powered by a 12 Volt battery (fitted to the machine). Battery recharging is assured by a coil alternator that receives impulses from the engine's magnet fly-wheel.

### SERVICING PROCEDURES

#### A) Removing the starter motor

- 1 Remove the magnet flywheel [➔ 6.9.E].
- 2 Disconnect the connector (1) from the machine's cabling.
- 3 Disconnect the power cable (2) and earth cable (3).
- 4 Unscrew the two screws (4) and remove the starter motor (5).
- 5 Reverse the above operations to reassemble; bear in mind the function of the three cables when reconnecting the connector (1):

blue = recharge  
red = starter motor power supply  
black = earth

- 6 Remove the flywheel [➔ 6.9.E]

#### B) Removing and cleaning the starter motor pinion

- 11 Remove the starter motor [➔ 6.11.A].
- 12 With the help of a screwdriver turn the pinion (11) and check that it can slide axially until it compresses the spring (12).
- 13 Should deposits and dirt prevent complete return proceed as follows:

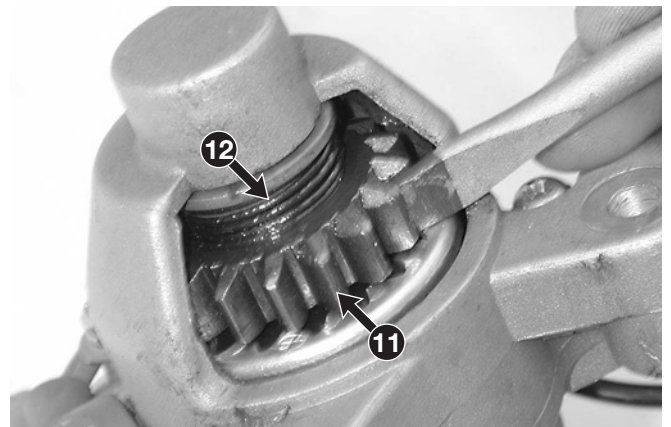
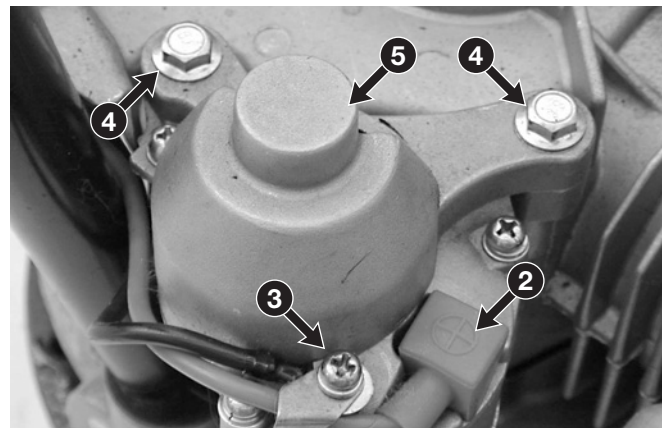
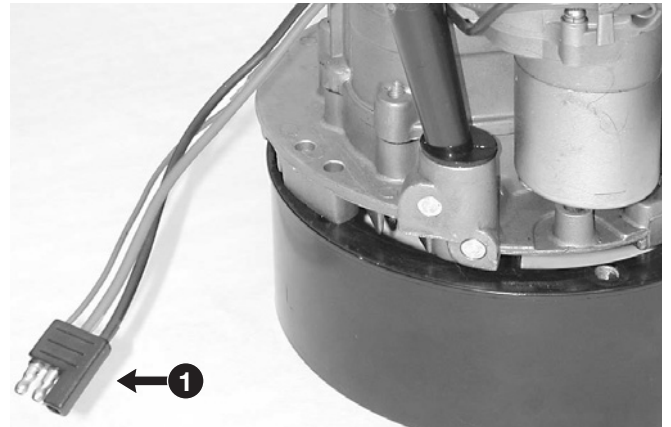
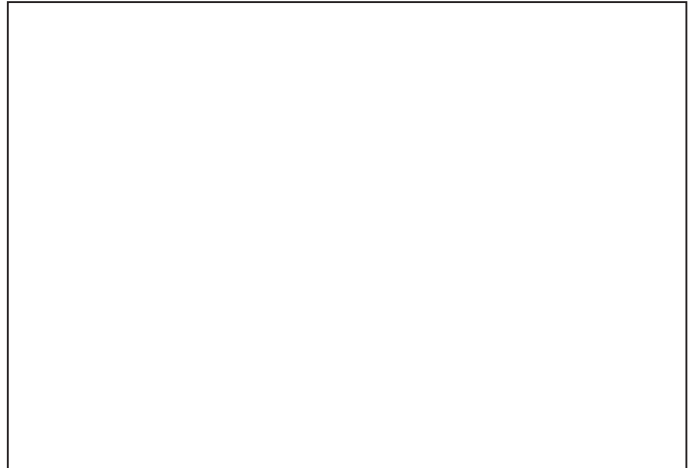

<p>◀ 6.11.0 - ELECTRICAL STARTING SYSTEM AND RECHARGE ALTERNATOR ▶</p>	<p>from 2007 to page ◀ 2 / 4 ▶</p>
--	--

- remove the dirt with a jet of compressed air;
- apply an unlocking spray and repeat the pinion movement;
- clean again with a jet of compressed air when movement becomes smooth;
- apply more unlocking spray as a lubricant.

Avoid the use of grease or oil that could favour the accumulation of dirt.

- 14 Fix the motor in a vice, connect it to a 12 Volt battery for 15-20 seconds and check that it operates regularly without overheating.
- 15 If operation is noisy, make a reference mark on the joint between the starter motor body and the pinion housing (13) and unscrew the three screws (14) to remove the pinion housing.
- 16 Extract the pinion group (15) and check the condition of the gears below.
- 17 Remount the pinion housing matching up the reference marks.
- 18 Remount the starter motor [[↩ 6.11.A](#)].

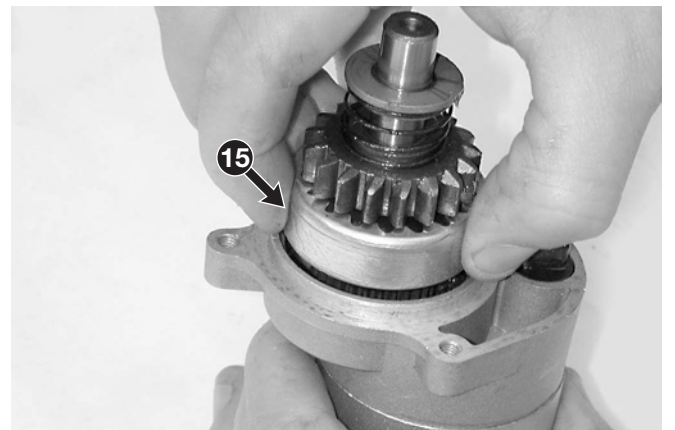
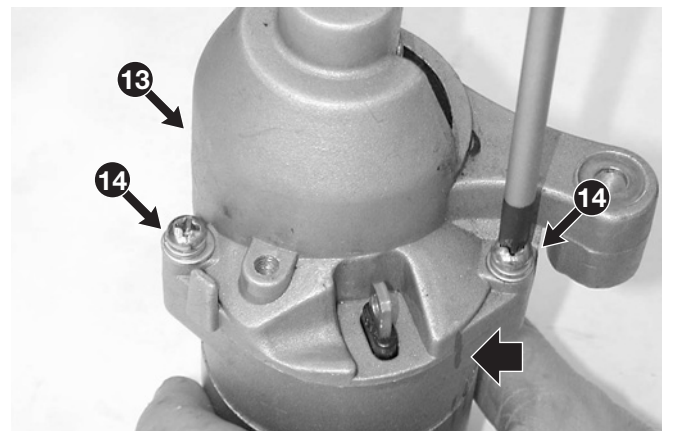

**C) Removing and checking the starter motor rotor**

- 21 Remove the starter motor [[↩ 6.11.A](#)].
- 22 Make a reference mark on the joint between the motor body and the lower cover (21) of the electrical part, unscrew the two screws (22) and remove the cover (21).
- 23 Remove the lower cover (21) taking care not to damage the sealing ring (23).

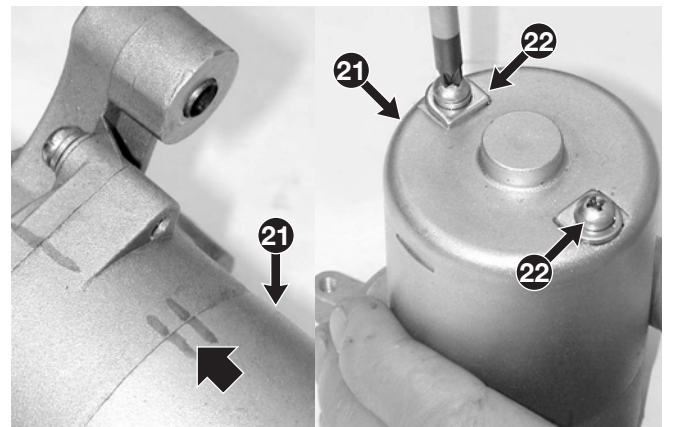

<b>6.11.0 - ELECTRICAL STARTING SYSTEM AND RECHARGE ALTERNATOR</b>	from 2007 to page 3 / 4
--	----------------------------

24 Check the condition of the brushes (24) and relative springs (25).

25 Extract the rotor (26) and make the electrical checks using a universal tester in Ohmmeter mode:

- with one test prod (27) on the rotor armature and the other (28) on the commutator bars the instrument should register that there is no passage of current;
- with the test prod (29) on the commutator bars, the instrument should register that there is no passage of current between any of the bars.

The starter motor must be replaced if this is not so.

26 On assembly, take care to reposition the brushes (24) correctly with respect to the rotor bars (26) and refit the sealing ring (23).

27 Remount the starter motor [↩ [6.11.A](#)].

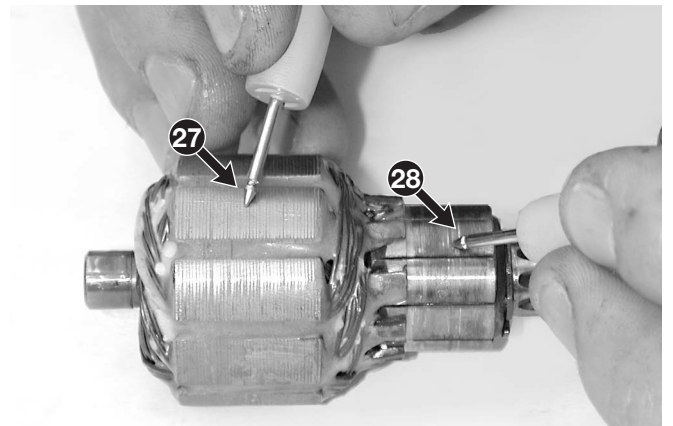
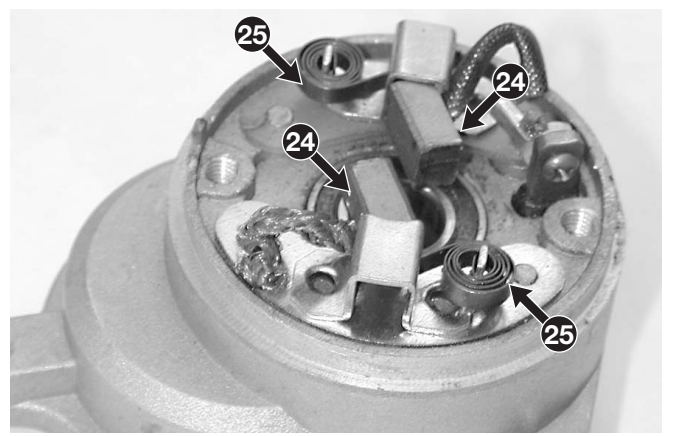
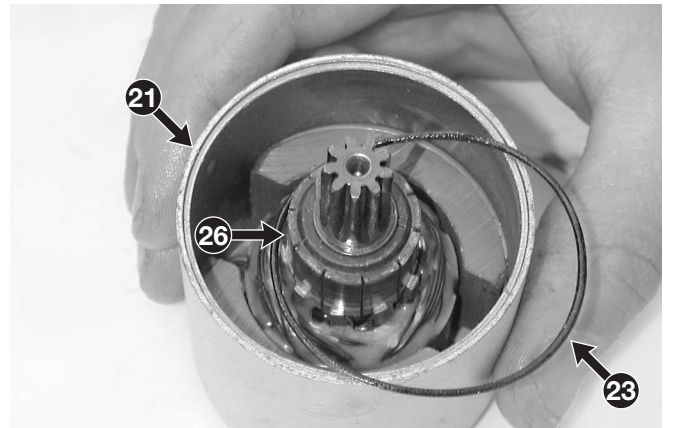

### D) Checking and adjusting the recharge alternator

31 Use an ammeter clamp (31) to check the recharge values in the following conditions of use:

- Battery charged - engine at minimum = 0,35-0,40 A
- Battery charged - engine at maximum = 0,45-0,50 A
- Battery discharged - engine at minimum = 0,40-0,45 A
- Battery discharged - engine at maximum = 0,45-0,55 A

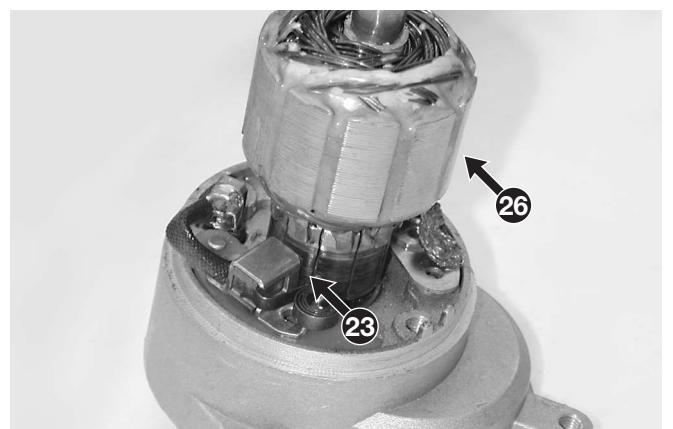
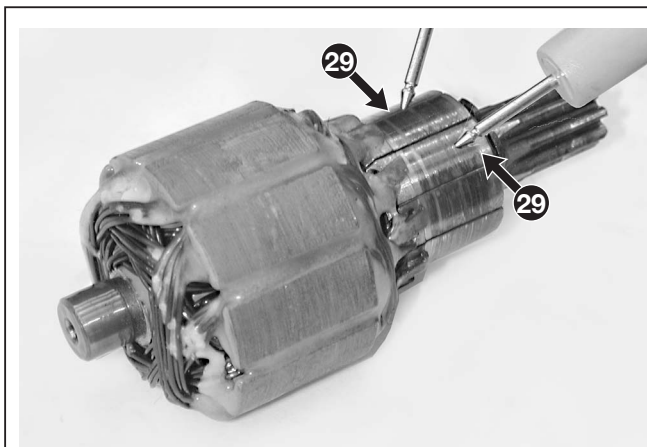

If different values are registered, make the checks described below and, if a satisfactory result is not obtained, the alternator must be replaced.

- 32 Remove the starting system [↔ 6.2.A].
- 33 Remount the tank [↔ 6.1.A].
- 34 Remove the conveyor (32).
- 35 Loosen the two screws (33) securing the alternator coil (34), release the brake manually and rotate the flywheel (35) until the magnetic inserts are lined up with the poles of the coil core (34).
- 36 Insert a 0.35 mm thickness gauge (36) between the magnet flywheel (35) and the coil poles. Push the coil until the poles come in contact with the thickness gauge and secure both screws (33). Tighten the screws remembering that the air gap must be between 0.25 and 0.40 mm.
- 37 Remount the conveyor (31).
- 38 Remount the tank [↔ 6.1.A].
- 39 Remount the starting system [↔ 6.2.A].

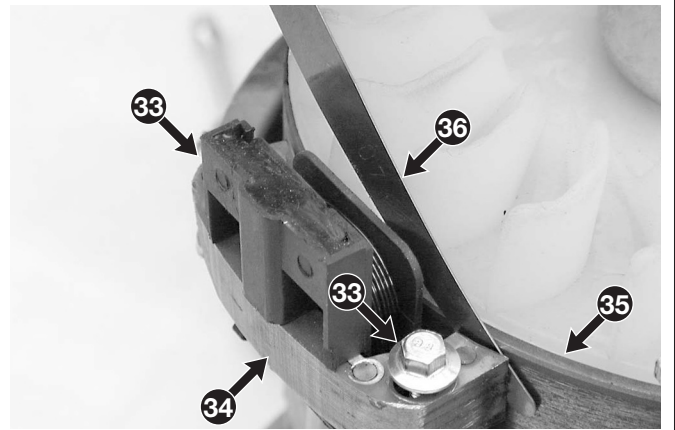
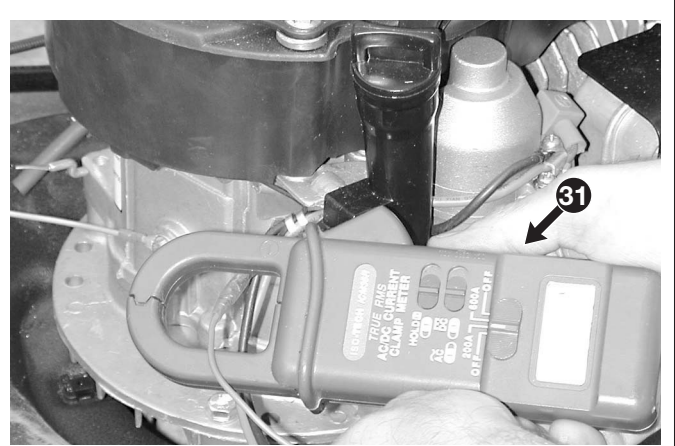

**Tightening torques**

4 Motor fixing screws ..... 8-10 Nm

**Technical information**

Recharge values ..... 0,45-0,55 Amps

**Special equipment**

- Universal tester
- Ammeter clamp