

Genuine Spare Parts

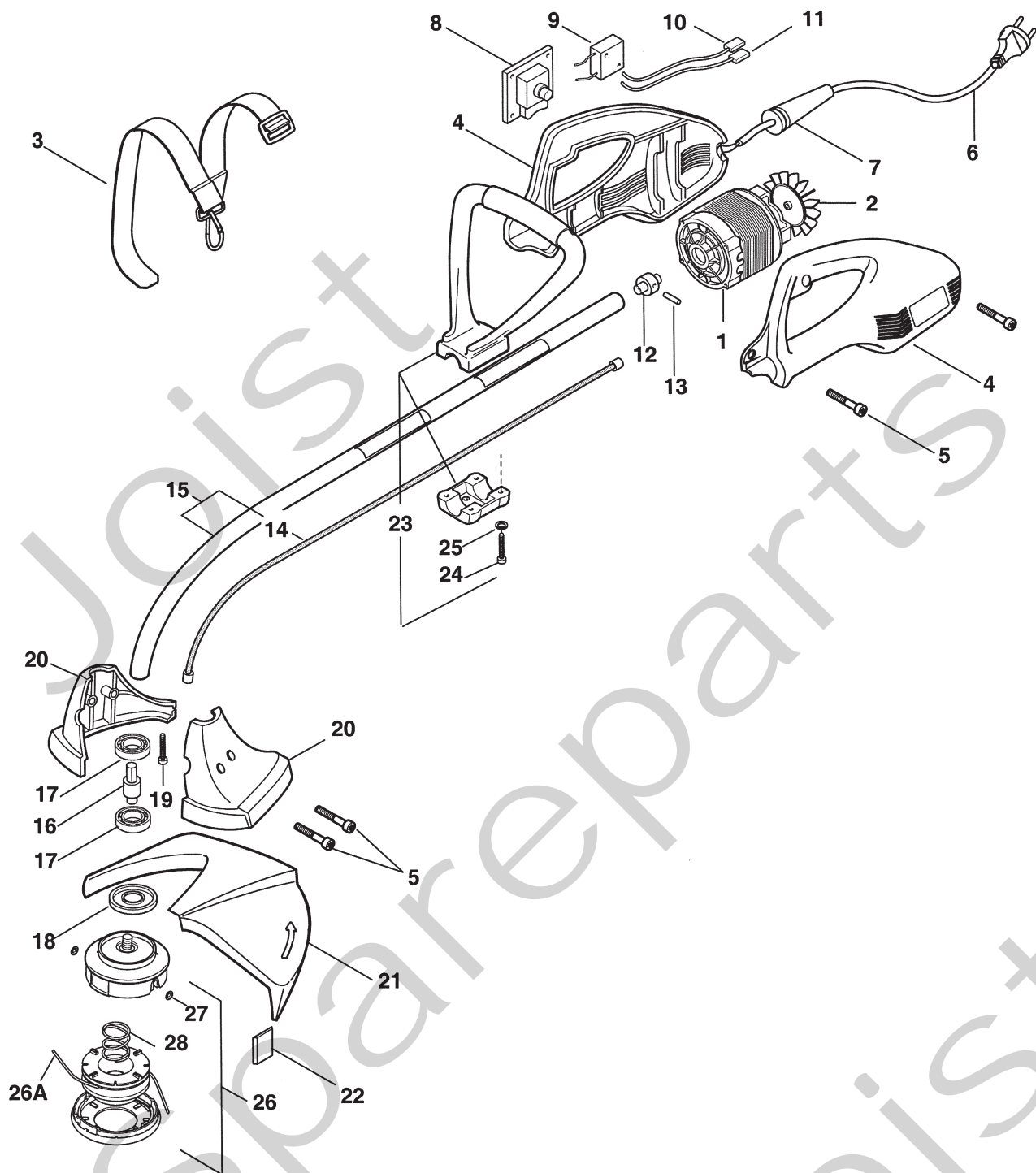

Joist
Spareparts
Joist



Utgåva Issue		Bildnr Picture No		ST 1100 ELTRIMMER	ST 1100 EL. TRIMMER	Sida Page		
2005- 12		1283D				246		
Pos. Fig.	Antal/Quantity			Art nr Part No	Benämning	Description	Sats Kit	Anmärkning Notes
	1100							
1	1			1911-3187-01	Motor kpl.....	Motor assy.....		Inkl. pos 2 ,12
2	1			1911-3738-01	• Fläkt.....	• Impeller.....		
3	1			1911-3151-01	Bärrem.....	Brace.....		
4	1			1911-3199-01	Handtagshalvor (vä+hö).....	Handgrip halves (L+R).....		
5	18			1911-3004-01	Skruv.....	Screw.....		
6	1			1911-3057-01	Anslutningsladd.....	Connection cable.....		
7	1			1911-3461-01	Kabelskydd.....	Cord protector.....		
8	1			1911-3314-01	Brytare.....	Switch.....		
9	1			1911-3056-01	Kondensator.....	Condensor.....		
10	1			1911-3058-01	Brytarkabel- lång.....	Switch cable- long.....		Hona/female
10	1			1911-3671-01	Brytarkabel- lång.....	Switch cable- long.....		Hane/male
11	1			1911-3059-01	Brytarkabel- kort.....	Switch cable- short.....		Hona/female
11	1			1911-3672-01	Brytarkabel- kort.....	Switch cable- short.....		Hane/male
12	1			1911-3120-01	• Axelkoppling.....	• Shaft joint.....		
13	1			1911-3064-01	Stift.....	Elastic plug.....		
14	1			1911-3153-01	• Flexdrivaxel.....	• Flexible shaft.....		
15	1			1911-3144-01	Drivaxelrör kpl.....	Transm.tube assy.....		Inkl. pos 14
16	1			1911-3084-01	Axel- skärhuvud.....	Shaft- nylon head.....		
17	2			1911-3040-01	Kullager.....	Ball bearing.....		
18	1			1911-3073-01	Ringmutter- övre.....	Ring nut- upper.....		
19	1			1911-3002-01	Skruv.....	Screw.....		
20	1			1911-3200-01	Kåpa (vä+hö).....	Head casing (L+R).....		
21	1			1911-3873-01	Skyddskåpa.....	Splash guard.....		
22	1			1911-3074-01	Knivblad.....	Line cutter blade.....		
23	1			1911-3184-01	Handtag- främre kpl.....	Handgrip- front assy.....		Inkl. pos 24, 25
24	4			1911-3003-01	• Skruv.....	• Screw.....		
25	8			1911-3015-01	• Bricka.....	• Washer.....		
X 26	1			1911-4150-01	Skärhuvud kpl.....	Nylon head assy.....		Inkl. pos 27, 28
26A	1			1911-9008-04	Skärtråd (2.4 mm).....	Cutting line (2.4 mm).....		0.45 kg (90 m)
26A	1			1911-9008-08	Skärtråd (2.4 mm).....	Cutting line (2.4 mm).....		15 m
27	2			1911-3875-01	• Trådhylsa.....	• Line inlet.....		
X 28	1			1911-4174-01	• Fjäder.....	• Spring.....		
99	1			1911-3212-01	Skyddsglasögon.....	Protective goggles.....		Ej ill/not ill.
99	1			1911-3219-01	Torx nyckel T25.....	Torx key T25.....		Ej ill/not ill.